

Micromotors

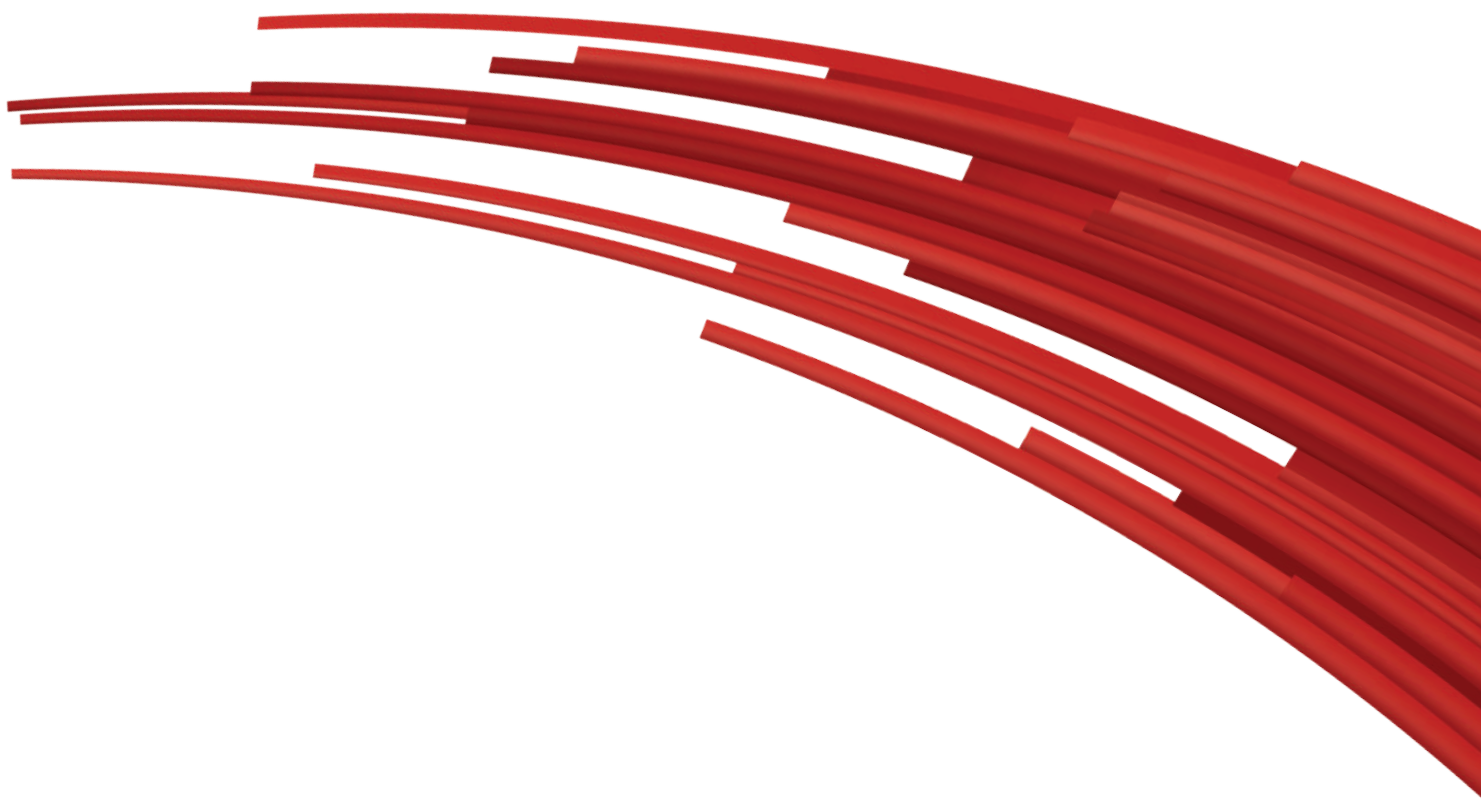

servotecnica

Connecting dots.
Providing Solutions.



Contents

ATOM EC SVTN A 01	Coreless BLDC motors 2 Pole Brushless DC Motors	up to 400W	ø12 .. 40mm	p. 6-33
	2 Pole High-Speed Brushless DC Motors	up to 150W	ø16 .. 20mm	p. 34-43
	2 Pole Brushless DC Motors with I.E.	up to 80W	ø12 .. 36mm	p. 44-59
ATOM HS SVTN A 02				
ATOM SC SVTN A 03				
ATOM DC SVTN B 01	Coreless DC Motors 2 Pole Brushed DC Motors	1.6 .. 150W	ø12 .. 40mm	p. 60-85
FLAT SVTM F	Flat Motors Outrunner Brushless DC Motors	5 .. 169W	ø20 .. 90mm	p. 86-99
COSMOS SVTG	Gearboxes Planetary Gearboxes	0.2 .. 45Nm	ø10 .. 52mm	p. 100-115
ACCESSORIES	Accessories Magnetic Incremental Encoders Servo drives PCB Board & Cables	25 .. 1024ppr	ø16 .. 22mm	p. 118-119 p. 120-139 p. 140-141



Expertise at your service

All-around services and solutions. A product selection and software development are the best proposal for specific applications.

In the automation and motion control industry since 1980, Servotecnica manufactures and proposes unique products based on cutting-edge technologies developed by leading global manufacturers.

The concernment of giving a wide range of products guarantees its presence in all sectors of the industry requiring high performances, skilled engineers, reducing machine developing time and offering a service support which grants a reliable partner for your applications.

Wide Range & Cost Effectiveness

A wide range of Micromotors supported by a 35+ years experience will translate into a proficient product selection and design, reducing time-to-market and increasing your competitiveness.



Custom

Thanks to our lean and flexible production, we can deliver specifically designed samples in accordance to the requirements of any of your applications in a very short time, thus to provide you with the best solution.



Industries

Medical & Lab



Dental devices
Surgical robots
Insulin pumps
Diagnosis

Robotics



Electric grippers
Humanoid robots
Inspection robots
Service robots

Automation



Packaging machines
Cobots
Welding equipments
Miniaturized pumps
Security lockers

Instruments



Calibration systems
Laser leveling systems

Automotive



Fuel injection pumps
Adjustable shock absorbers
Electric vehicles
Driver-assisted systems
Power steering

Aerospace



Radar systems
Flap adjustments
Seat and display adjustments

Video Systems



Seurveillance cameras
Mobile inspection systems
Professional cameras

Consumer Applications

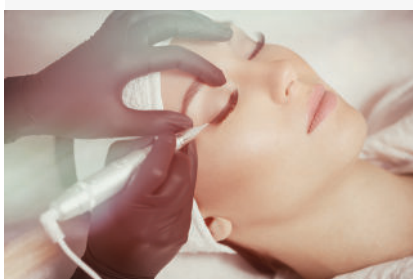

Tattoo Machines
Permanent make-up
Massage Chairs
Bicycle shift systems
Moving head projectors

Optics



Automatic focus
Lasers
Ophthalmology
Microscopes

ATOM EC Series

SVTN A 01

Coreless BLDC motors
2 Pole Brushless DC Motors

Contents

Model	W	Ø [mm]	Page
SVTN A 01-1220	up to 8	12	12
SVTN A 01-1230	up to 15	12	13
SVTN A 01-1630	up to 12	16	14
SVTN A 01-1636	up to 21	16	15
SVTN A 01-2040	up to 32	20	16
SVTN A 01-2232	up to 20	22	17
SVTN A 01-2240	up to 39	22	18
SVTN A 01-2248	up to 43	22	19
SVTN A 01-2260	up to 70	22	20
SVTN A 01-2446	up to 42	24	21
SVTN A 01-2453	up to 54	24	22
SVTN A 01-2845	up to 35	28	23
SVTN A 01-2854	up to 72	28	24
SVTN A 01-2864	up to 88	28	25
SVTN A 01-3242	up to 60	32	26
SVTN A 01-3260	up to 120	32	27
SVTN A 01-3270	up to 130	32	28
SVTN A 01-3660	up to 140	36	29
SVTN A 01-3670	up to 250	36	30
SVTN A 01-4058	up to 150	40	31
SVTN A 01-4070	up to 210	40	32
SVTN A 01-4088	up to 400	40	33

ATOM EC Series

SVTN A 01

Coreless BLDC motors
2 Pole Brushless DC Motors



Cost effective



High power density



High efficiency



The benefits of this new technology are torque and high-speed when compared to same sizing. The lack of cogging, a reduced ripple torque, a linear correlation between speed and torque, low inertia bring performance to greater level in terms of power, dynamics by means of reduced weights and reduced dimensions.

Servotecnica's brushless motors apply hall sensors as a standard option, in addition to having the magnetic encoder option. Thanks to the sensors it is possible to control rotation speed, and, thanks to the lack of cogging, provide high performance and accuracy.

Benefits

High power density	Long operational lifetime
High efficiency	No cogging
High reliability	Low inertia
Low noise	Robust
Low inductance	Cost-effective
Good heat dissipation	

Product code

SVTN A 01 - ○○◇◇ - □□ - ◇ - ◇☆☆☆

A Series

01 Brushless DC Motors

○ Diameter

◇ Length

□ Nominal Voltage

◇ Shaft
Single shaft - standard [S]; Double shaft [D]

◇ Sensor
Sensorless [0]; Hall sensor [H]*

☆☆☆ Customizations

* Standard option from SVTN A 01 1630 onwards.

Features

Winding	3 phase
Operating temperature	-30° +100° C
Connectors	JST PHR-8 1630; 1636; 2040; 2232; 2240; 2248; 2260; 2446; 2453; 2845; 2854; 2864 MOLEX 39-01-2080 3242; 3260; 3270; 3660; 3670; 4058; 4070; 4088
Magnets	Neodymium
Construction technology	Coreless winding system
Estimated operating lifetime	Lifetime depends on motor working conditions. It can reach 20.000 work hours under optimal conditions (almost 100 hours under extreme conditions).

Feedback

Hall Sensor (standard)

Magnetic encoder** 3 channels, from 25 to 1024 ppr

Customizations

Hall Sensor (standard)

Shaft Length/Diameter/D-Cut/double shaft

Leadwire PVC/Silicon/Teflon/UL No/Dimension/length

Connector JST/MOLEX

**See page 115 for more information

Explanation of the performance diagram

The performance diagram shows the range of possible operating points of a drive at an ambient temperature of 25°C and includes both the operation in the thermally insulated and in the cooled state. The possible speed ranges are shown in dependence on the shaft torque.

The sector shown dashed describes potential operating points in which the drive can be engaged in intermittent operation or with increased cooling.

Nominal torque [mNm]

Describes the max. continuous torque in the steady state at nominal voltage and with a thermal reduction of the R_{th2} value by 50 %. The continuous speed decreases linearly vis-a-vis the continuous torque. In the case of slotted flat brushless motors, this point is indicated with the motor mounted on a metal flange and is the same as MN. The continuous torque is independent of the continuous output power and can be exceeded if the motor is operated intermittently, for example, in S2 operation and/or if more cooling is applied.

Nominal output power [W]

Describes the max. possible output power in continuous operation in steady state with a thermal reduction of the R_{th2} value by 50 %. The value is independent of the continuous torque, responds linearly to the cooling factor and can be exceeded if the motor is operated intermittently, for example, in S2 operation and/or if more cooling is applied.

Nominal voltage curve [V]

The nominal voltage curve describes the operating points at UN in the uncooled and cooled state. In steady state, the starting point corresponds to the no-load speed n_0 the drive. Operating points above this curve can be attained by an increase, operating points below by a reduction of the nominal voltage.

Additional Information for Slotted Brushless Motors The performance curves for slotted motors with a housing will be significantly different than the diagrams of the motors without housing. Typically motors without a housing will have a higher performance due to the effects of ambient air flow cooling.

*The diagram based on ambient temperature of 25°.

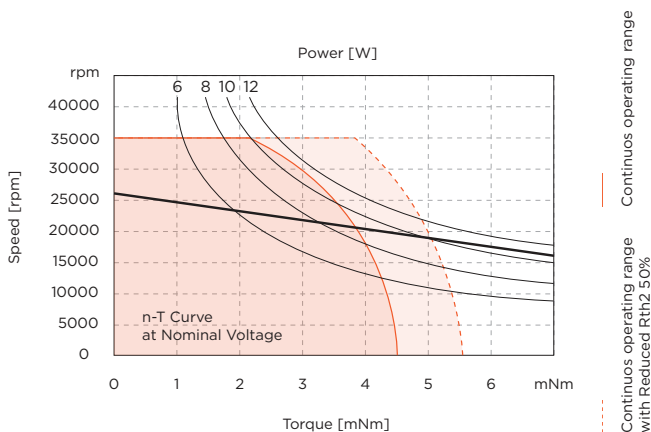

Example: Power diagram for rated values at continuous operation.

Table explanation

1 Nominal voltage

It is the applied voltage between two powered phases in block commutation. All nominal data (lines 2 – 9) refer to this voltage. Lower and higher voltages are permissible, provided that limits are not exceeded.

2 No load speed

It is the speed at which the unloaded motor runs with the nominal voltage applied. It is proportional to the applied voltage.

3 No load current

This is the typical current that the unloaded motor draws when operating at nominal voltage. No load friction depends heavily on temperature. It decreases in extended operation and increases at lower temperatures.

4 Nominal speed

It is the speed set for operation at nominal voltage and nominal torque at a motor temperature of 25°C.

5 Nominal torque

It is the torque generated for operation at nominal voltage and nominal current at a motor temperature of 25°C. It is at the limit of the motor's continuous operation range. Higher torques heat up the winding too much.

6 Nominal current

It is the current in the active phase the nominal torque at the given nominal speed (= max. permissible continuous load current). The maximum winding temperature is reached at 25°C ambient temperature in continuous operation with Nominal current.

7 Stall torque

It is the linearly calculated load torque for motors that causes the shaft to stall at nominal voltage. This torque often cannot be achieved due to saturation effects.

8 Stall current

It is the quotient from nominal voltage and the motor's terminal resistance. Stall current is equivalent to stall torque. With larger motors, Stall current cannot be reached due to the amplifier's current limits.

9 Max. efficiency

It is the optimal relationship between input and output power at nominal voltage. Contact factory for more detail.

10 Terminal resistance

It is determined by the resistance at 25 °C between two motor phase.

11 Terminal inductance

It is the winding inductance between two motor phase.

12 Torque constant

Represents the quotient from generated torque and applicable current.

13 Speed constant

It indicates the theoretical no load speed per volt of applied voltage, disregarding friction losses.

14 Speed/torque gradient

The speed/torque gradient is an indicator of the motor's performance. It is based on the quotient of ideal no load speed and ideal stall torque (tolerance $\pm 20\%$).

15 Mechanical time constant

It is the time required for the rotor to accelerate from standstill to 63% of its no load speed.

16 Rotor inertia

It is the mass moment of inertia of the rotor.

17 Thermal resistance housing-ambient

Characteristic values of thermal contact resistance without additional heat sinking. Lines 17 and 18 combined define the maximum heating at a given power loss (load). Thermal resistance Rth2 on motors with metal flanges can decrease by up to 80% if the motor is coupled directly to a good heat-conducting.

18 Thermal resistance winding-housing

Characteristic values of thermal contact resistance without additional heat sinking. Lines 17 and 18 combined define the maximum heating at a given power loss (load). Thermal resistance Rth2 on motors with metal flanges can decrease by up to 80% if the motor is coupled directly to a good heat-conducting.

19 Thermal time constant winding

These are the typical reaction times for a temperature change of winding and motor. It can be seen that the motor reacts much more sluggishly in thermal terms than the winding. The values are calculated from the product of thermal capacity and given heat resistances.

20 Thermal time constant motor

These are the typical reaction times for a temperature change of winding and motor. It can be seen that the motor reacts much more sluggishly in thermal terms than the winding. The values are calculated from the product of thermal capacity and given heat resistances.

21 Ambient temperature

Operating temperature range. This derives from the heat reliability of the materials.

22 Max. permissible winding temperature

Maximum permissible winding temperature.

23 Max. permissible speed

It is the maximum recommended speed based on thermal and mechanical perspectives. A reduced service life can be expected at higher speeds.

24 Radial play

Radial play is the bearing's radial movement

25 Max. axial load (dynamics)

Dynamic: axial loading permissible in operation. If different values apply for traction and thrust, the smaller value is given.

26 Max force for press fits (static)

Maximum axial force applying to the shaft at standstill if the force is not input at the other shaft end. This is not possible for motors with only one shaft end.

27 Max. radial load

The value is given for a typical distance from the front flange. As the distance increases, this value decreases.

28 Number of pole pairs

Number of north poles of the permanent magnet. The phase streams and commutation signals pass through per revolution p cycles. Servo-controllers require the correct details of the number of pole pairs.

29 Number of phases

All motors have three phases.

30 Weight



ATOM EC Series SVTN A 01-1220

8 Watt

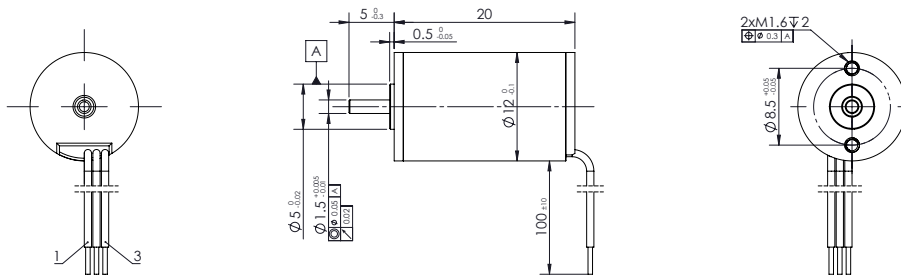
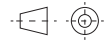

V 3

Values	Unit	SVTN A 01 1220-06..	1220-09..
--------	------	------------------------	-----------

Motor Data				
1	Nominal voltage	V	6	9
2	No load speed	rpm	25000	36890
3	No load current	mA	69	83
4	Nominal speed	rpm	16536	29888
5	Nominal torque	mNm	1,5	1,3
6	Nominal current	A	0,75	0,66
7	Stall torque	mNm	4,43	6,85
8	Stall current	A	2,07	3,1
9	Max. efficiency	%	66,8	70
Characteristics				
10	Terminal resistance*	Ω	2,9	2,9
11	Terminal inductance*	mH	0,19	0,19
12	Torque constant	mNm/A	2,22	2,27
13	Speed constant	rpm/V	4310	4212
14	Speed/torque gradient	rpm/mNm	5642	5386
15	Mechanical time constant	ms	10	9,6
16	Rotor inertia	gcm ²	0,17	0,17

Mechanical data		
17	Thermal resistance housing-ambient	38.3 K/W
18	Thermal resistance winding-housing	9.6 K/W
19	Thermal time constant winding	5 s
20	Thermal time constant motor	196 s
21	Ambient temperature	-30...+100°C
22	Max. permissible winding temperature	+125°C
23	Max. permissible speed	50000 rpm
24	Radial play	preloaded
25	Max. axial load (dynamic)	0,3
26	Max. force for press fits (static)	11N
27	Max. radial load, 5mm from flange	4.3 N
Other specifications		
28	Number of poles	2
29	Number of phases	3
30	Weight	9,8g

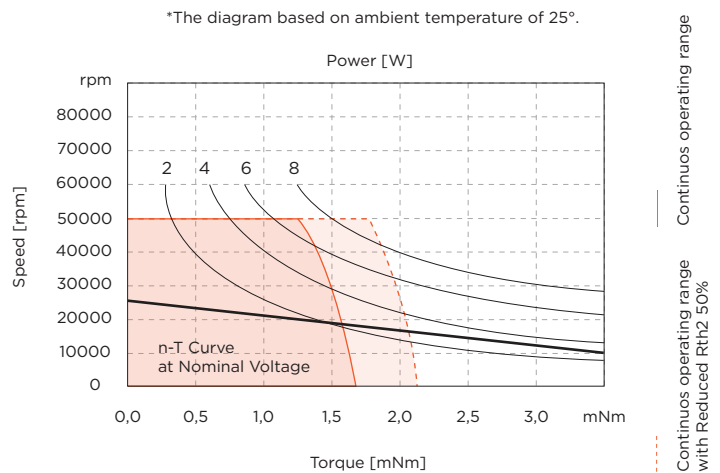

Connection			
Connection 0	(Sensorless)	PVC	
Pin 1	Motor winding MA	AWG28	yellow
Pin 2	Motor winding MB	AWG28	green
Pin 3	Motor winding MC	AWG28	blue

Gearbox combinations	
SVTG A 10*	
SVTG A 12*	
*On request	



ATOM EC Series
SVTN A 01-1230

15 Watt



servotecnica
CORELESS
BRUSHLESS

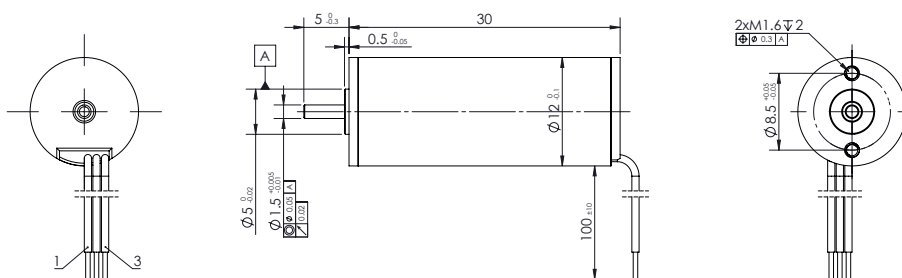

V 3

Values	Unit	SVTN A 01 1230-06..	1230-09..	1230-12..
--------	------	------------------------	-----------	-----------

Motor Data					
1	Nominal voltage	V	6	9	12
2	No load speed	rpm	25310	25100	24930
3	No load current	mA	122	90	72
4	Nominal speed	rpm	20719	20565	20449
5	Nominal torque	mNm	3	3	3
6	Nominal current	A	1,47	0,98	0,74
7	Stall torque	mNm	16,5	16,6	16,7
8	Stall current	A	7,55	5,03	3,77
9	Max. efficiency	%	76,2	75	74,3
Characteristics					
10	Terminal resistance*	Ω	0,8	1,79	3,18
11	Terminal inductance*	mH	0,02	0,04	0,08
12	Torque constant	mNm/A	2,23	3,36	4,51
13	Speed constant	rpm/V	4288	2840	2118
14	Speed/torque gradient	rpm/mNm	1530	1512	1494
15	Mechanical time constant	ms	5,1	5,1	5
16	Rotor inertia	gcm ²	0,32	0,32	0,32

Mechanical data		
17	Thermal resistance housing-ambient	28.4 K/W
18	Thermal resistance winding-housing	7.1 K/W
19	Thermal time constant winding	4 s
20	Thermal time constant motor	240 s
21	Ambient temperature	-30...+100°C
22	Max. permissible winding temperature	+125°C
23	Max. permissible speed	50000 rpm
24	Radial play	preloaded
25	Max. axial load (dynamic)	0,3
26	Max. force for press fits (static)	11N
27	Max. radial load, 5mm from flange	4.3 N
Other specifications		
28	Number of poles	2
29	Number of phases	3
30	Weight	16.3 g

*The diagram based on ambient temperature of 25°.

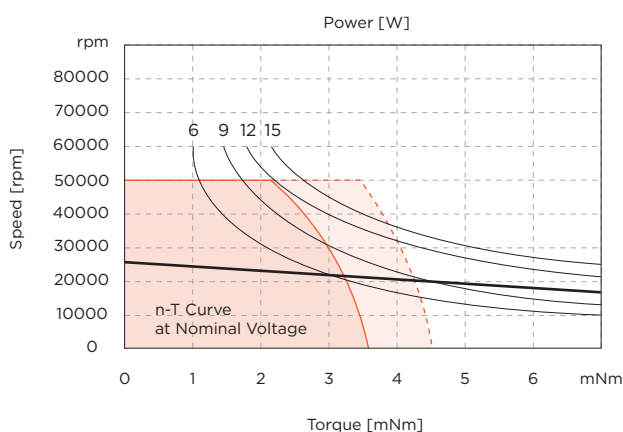

Continuous operating range
Continuous operating range with Reduced Rth2 50%

Connection

Connection 0	(Sensorless)	PVC
Pin 1	Motor winding MA	AWG28 yellow
Pin 2	Motor winding MB	AWG28 green
Pin 3	Motor winding MC	AWG28 blue

Gearbox combinations

SVTG A 10*
SVTG A 12*

*On request



ATOM EC Series SVTN A 01-1630

12 Watt

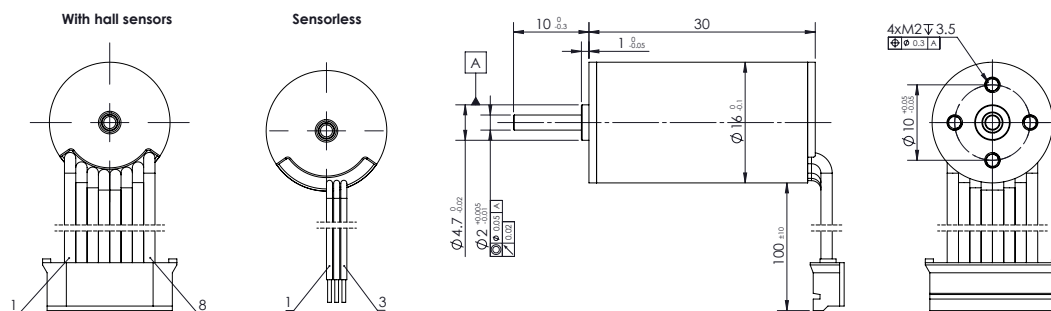

V 3

Values	Unit	SVTN A 01	1630-12..	1630-18..	1630-24..
Motor Data					
1	Nominal voltage	V	12	18	24
2	No load speed	rpm	23220	23511	23760
3	No load current	mA	210	150	100
4	Nominal speed	rpm	19138	19506	19203
5	Nominal torque	mNm	3,5	3,5	3,5
6	Nominal current	A	0,95	0,65	0,48
7	Stall torque	mNm	19,9	20,5	18,2
8	Stall current	A	4,44	3,1	2,09
9	Max. efficiency	%	61,3	60,9	61
Characteristics					
10	Terminal resistance*	Ω	2,7	5,8	11,5
11	Terminal inductance*	mH	0,08	0,17	0,33
12	Torque constant	mNm/A	4,7	6,96	9,18
13	Speed constant	rpm/V	2031	1373	1040
14	Speed/torque gradient	rpm/mNm	1166	1144	1302
15	Mechanical time constant	ms	5,8	5,7	6,5
16	Rotor inertia	gcm ²	0,48	0,48	0,48
Mechanical data					
17	Thermal resistance housing-ambient		20.0 K/W		
18	Thermal resistance winding-housing		8.8 K/W		
19	Thermal time constant winding		8 s		
20	Thermal time constant motor		236 s		
21	Ambient temperature		-30...+100°C		
22	Max. permissible winding temperature		+150°C		
23	Max. permissible speed		35000 rpm		
24	Radial play		preloaded		
25	Max. axial load (dynamic)		1.3 N		
26	Max. force for press fits (static)		15 N		
27	Max. radial load, 5mm from flange		5 N		
Other specifications					
28	Number of poles		2		
29	Number of phases		3		
30	Weight		25 g		

*The diagram based on ambient temperature of 25°.

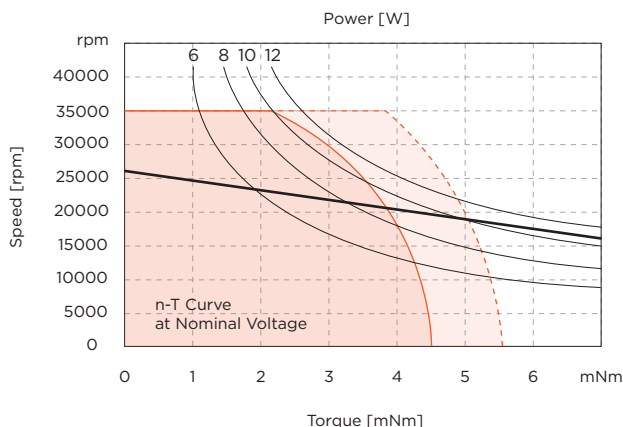

Continuous operating range
Continuous operating range with Reduced Rth2 50%

Connection

Connection H (Sensor)	PVC		
Pin 1	Vhall 3-18 VDC	AWG26	black
Pin 2	Hall sensor HA	AWG26	black
Pin 3	Hall sensor HB	AWG26	black
Pin 4	Hall sensor HC	AWG26	black
Pin 5	GND	AWG26	black
Pin 6	Motor winding MA	AWG26	black
Pin 7	Motor winding MB	AWG26	black
Pin 8	Motor winding MC	AWG26	black
Connector	PHR-8		
Connection O (Sensorless)			
Pin 1	Motor winding MA	AWG26	yellow
Pin 2	Motor winding MB	AWG26	green
Pin 3	Motor winding MC	AWG26	blue

Drive combinations

Hall sensor	Encoder
SVTE-A-E40	SVTE-A-E45
SVTE-A-E50	SVTE-A-E55
Encoder combinations	
EN 16A	EN 16AL
Gearbox combinations	
SVTG A 16	



ATOM EC Series
SVTN A 01-1636

21 Watt



servotecnica
CORELESS
BRUSHLESS

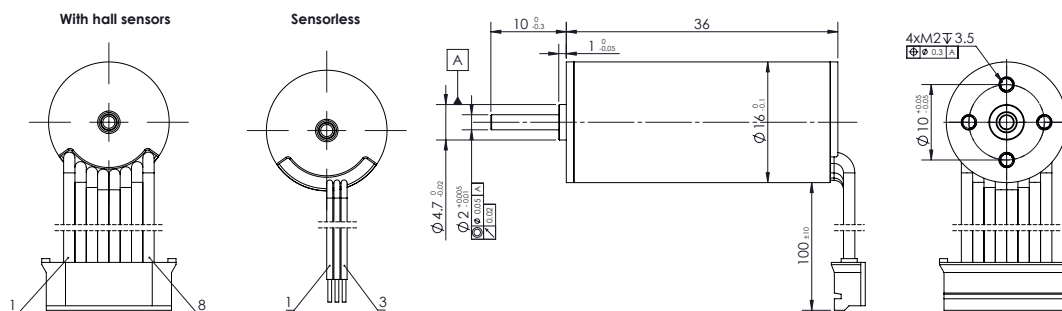

V 3

Values	Unit	SVTN A 01	1636-06..	1636-09..	1636-12..	1636-24..
--------	------	-----------	-----------	-----------	-----------	-----------

Motor Data						
1	Nominal voltage	V	6	9	12	24
2	No load speed	rpm	13835	14533	14460	14668
3	No load current	mA	150	110	70	50
4	Nominal speed	rpm	11412	11930	11615	12005
5	Nominal torque	mNm	6	6	6	6
6	Nominal current	A	1,62	1,14	0,84	0,44
7	Stall torque	mNm	34,3	33,5	30,5	33
8	Stall current	A	8,57	5,88	3,99	2,21
9	Max. efficiency	%	75,3	74,5	75,3	72,2
Characteristics						
10	Terminal resistance*	Ω	0,7	1,53	3,01	10,8
11	Terminal inductance*	mH	0,04	0,08	0,15	0,81
12	Torque constant	mNm/A	4,07	5,8	7,79	15,3
13	Speed constant	rpm/V	2347	1646	1227	625
14	Speed/torque gradient	rpm/mNm	404	434	474	444
15	Mechanical time constant	ms	2,6	2,8	3,1	2,9
16	Rotor inertia	gcm ²	0,62	0,62	0,62	0,62

Mechanical data		
17	Thermal resistance housing-ambient	17,1 K/W
18	Thermal resistance winding-housing	5,3 K/W
19	Thermal time constant winding	6 s
20	Thermal time constant motor	252 s
21	Ambient temperature	-30...+100°C
22	Max. permissible winding temperature	+150°C
23	Max. permissible speed	35000 rpm
24	Radial play	preloaded
25	Max. axial load (dynamic)	1,3 N
26	Max. force for press fits (static)	15 N
27	Max. radial load, 5mm from flange	5 N
Other specifications		
28	Number of poles	2
29	Number of phases	3
30	Weight	32 g

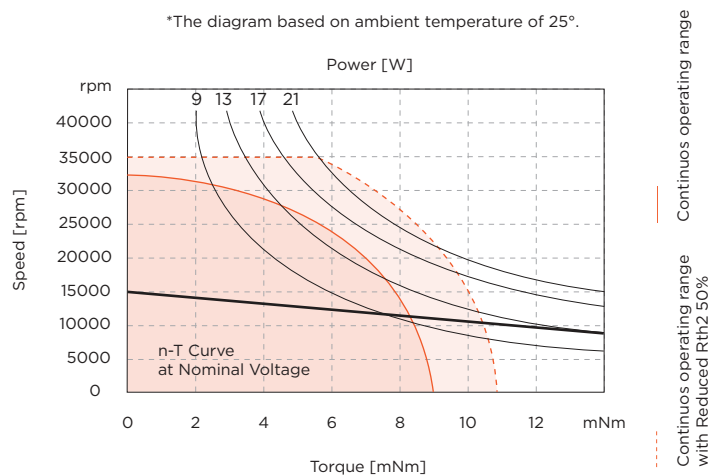

Connection

Connection H (Sensor) PVC			
Pin 1	Vhall 3-18 VDC	AWG26	black
Pin 2	Hall sensor HA	AWG26	black
Pin 3	Hall sensor HB	AWG26	black
Pin 4	Hall sensor HC	AWG26	black
Pin 5	GND	AWG26	black
Pin 6	Motor winding MA	AWG26	black
Pin 7	Motor winding MB	AWG26	black
Pin 8	Motor winding MC	AWG26	black
Connector JST PHR-8			
Connection O (Sensorless)			
Pin 1	Motor winding MA	AWG26	yellow
Pin 2	Motor winding MB	AWG26	green
Pin 3	Motor winding MC	AWG26	blue

Drive combinations

Hall sensor	Encoder
SVTE-A-E40	SVTE-A-E45
SVTE-A-E50	SVTE-A-E55
Encoder combinations	
EN 16A	EN 16AL
Gearbox combinations	
SVTG A 16	



ATOM EC Series SVTN A 01-2040

32 Watt

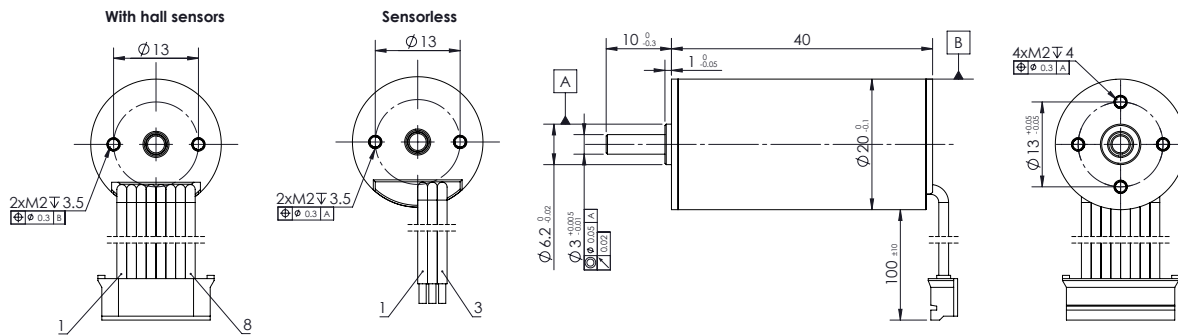
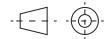

V 3

Values	Unit	SVTN A 01	2040-12..	2040-18..	2040-24..	2040-36..
Motor Data						
1	Nominal voltage	V	12	18	24	36
2	No load speed	rpm	17780	18360	18500	18880
3	No load current	mA	149	137	105	83
4	Nominal speed	rpm	15083	16171	16042	16164
5	Nominal torque	mNm	10	10	10	10
6	Nominal current	A	1,72	1,22	0,93	0,64
7	Stall torque	mNm	65,9	83,9	75,3	69,5
8	Stall current	A	10,5	9,23	6,28	3,98
9	Max. efficiency	%	77,6	77,1	75,8	73,2
Characteristics						
10	Terminal resistance*	Ω	1,14	1,95	3,82	9,04
11	Terminal inductance*	mH	0,08	0,17	0,3	0,62
12	Torque constant	mNm/A	6,35	9,22	12,18	17,83
13	Speed constant	rpm/V	1503	1035	784	536
14	Speed/torque gradient	rpm/mNm	270	219	246	272
15	Mechanical time constant	ms	6,4	5,2	5,8	6,4
16	Rotor inertia	gcm ²	2,3	2,3	2,3	2,3
Mechanical data						
17	Thermal resistance housing-ambient		13,8 K/W			
18	Thermal resistance winding-housing		4,3 K/W			
19	Thermal time constant winding		8 s			
20	Thermal time constant motor		366 s			
21	Ambient temperature		-30...+100°C			
22	Max. permissible winding temperature		+150°C			
23	Max. permissible speed		35000 rpm			
24	Radial play		preloaded			
25	Max. axial load (dynamic)		3,5 N			
26	Max. force for press fits (static)		44 N			
27	Max. radial load, 5mm from flange		15 N			
Other specifications						
28	Number of poles		2			
29	Number of phases		3			
30	Weight		56 g			

*The diagram based on ambient temperature of 25°.

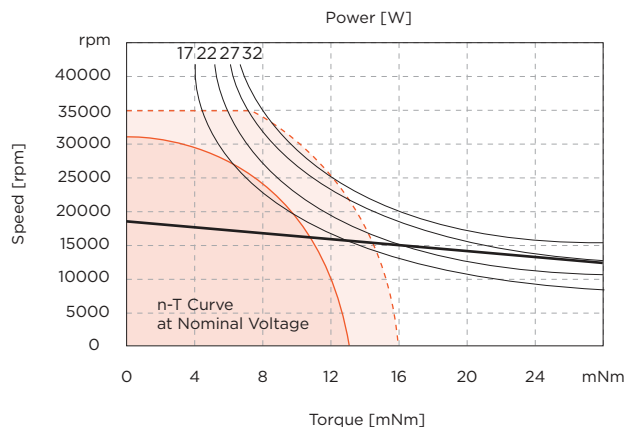

Continuous operating range
Continuous operating range with Reduced Rth2 50%

Connection

Connection H (Sensor)	PVC
Pin 1	Vhall 3-18 VDC
Pin 2	Hall sensor HA
Pin 3	Hall sensor HB
Pin 4	Hall sensor HC
Pin 5	GND
Pin 6	Motor winding MA
Pin 7	Motor winding MB
Pin 8	Motor winding MC
Connector	JST PHR-8
Connection O (Sensorless)	
Pin 1	Motor winding MA
Pin 2	Motor winding MB
Pin 3	Motor winding MC

Drive combinations

Hall sensor	Encoder
SVTE-A-E40	SVTE-A-E45
SVTE-A-E50	SVTE-A-E55
Encoder combinations	
EN 22A	EN 22AL
Gearbox combinations	
SVTG B 22	



ATOM EC Series
SVTN A 01-2232

20 Watt



servotecnica
CORELESS
BRUSHLESS

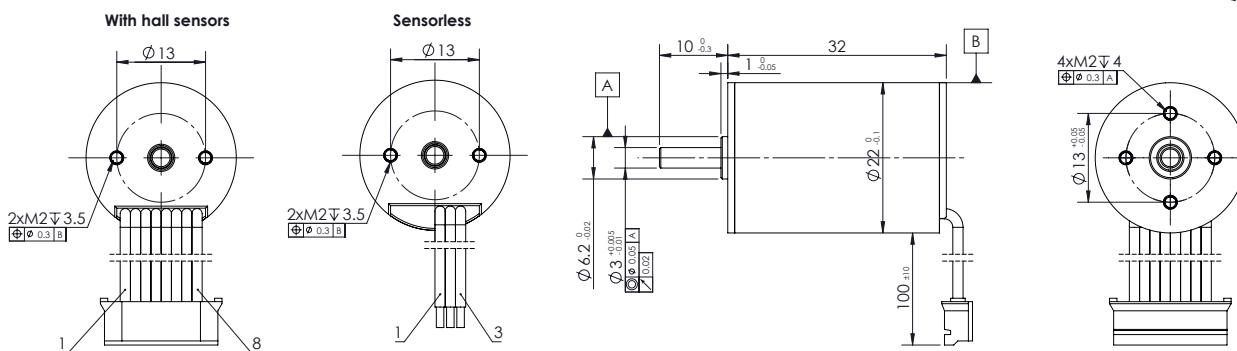

V 3

Values	Unit	SVTN A 01	2232-06..	2232-12..	2232-18..	2232-24..
--------	------	-----------	-----------	-----------	-----------	-----------

Motor Data		SVTN A 01	2232-06..	2232-12..	2232-18..	2232-24..
1	Nominal voltage	V	6	12	18	24
2	No load speed	rpm	11700	11184	12080	12164
3	No load current	mA	230	150	86	60
4	Nominal speed	rpm	9585	9023	9937	9358
5	Nominal torque	mNm	6	6	6	6
6	Nominal current	A	1.5	0.76	0.52	0.39
7	Stall torque	mNm	33.2	31.1	33.8	26
8	Stall current	A	7.23	3.32	2.55	1.5
9	Max. efficiency	%	67.5	62	66.6	64
Characteristics		SVTN A 01	2232-06..	2232-12..	2232-18..	2232-24..
10	Terminal resistance*	Ω	0.83	3.61	7.07	16
11	Terminal inductance*	mH	0.08	0.28	0.66	1.72
12	Torque constant	mNm/A	4.74	9.78	13.7	18.1
13	Speed constant	rpm/V	2014	976	695	528
14	Speed/torque gradient	rpm/mNm	353	360	357	468
15	Mechanical time constant	ms	5.5	5.6	5.6	7.3
16	Rotor inertia	gcm ²	1.5	1.5	1.5	1.5

Mechanical data		Value
17	Thermal resistance housing-ambient	15.2 K/W
18	Thermal resistance winding-housing	6.0 K/W
19	Thermal time constant winding	11 s
20	Thermal time constant motor	383 s
21	Ambient temperature	-30...+100°C
22	Max. permissible winding temperature	+150°C
23	Max. permissible speed	35000 rpm
24	Radial play	preloaded
25	Max. axial load (dynamic)	3.5 N
26	Max. force for press fits (static)	44 N
27	Max. radial load, 5mm from flange	15 N
Other specifications		Value
28	Number of poles	2
29	Number of phases	3
30	Weight	48 g

*The diagram based on ambient temperature of 25°.

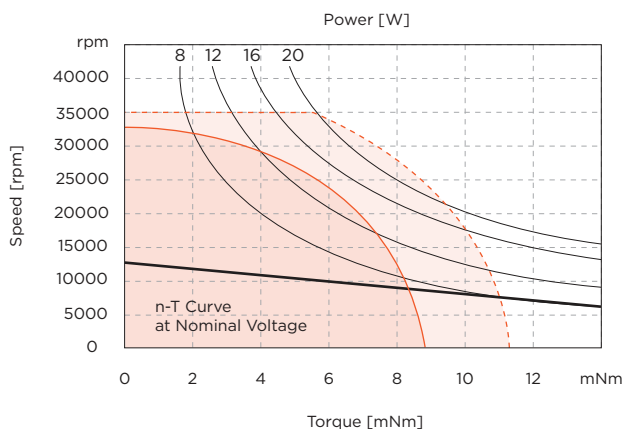

Continuous operating range
Continuous operating range with Reduced RthZ 50%

Connection

Connection H	(Sensor)	PVC	
Pin 1	Vhall 3-18 VDC	AWG26	black
Pin 2	Hall sensor HA	AWG26	black
Pin 3	Hall sensor HB	AWG26	black
Pin 4	Hall sensor HC	AWG26	black
Pin 5	GND	AWG26	black
Pin 6	Motor winding MA	AWG26	black
Pin 7	Motor winding MB	AWG26	black
Pin 8	Motor winding MC	AWG26	black
Connector			
JST	PHR-8		
Connection O	(Sensorless)		
Pin 1	Motor winding MA	AWG26	yellow
Pin 2	Motor winding MB	AWG26	green
Pin 3	Motor winding MC	AWG26	blue

Drive combinations

Hall sensors	Encoder
SVTE-A-E40	SVTE-A-E45
SVTE-A-E50	SVTE-A-E55

Encoder combinations

EN 22A
EN 22AL

Gearbox combinations

SVTG B 22
SVTG B 24



ATOM EC Series SVTN A 01-2240

39 Watt

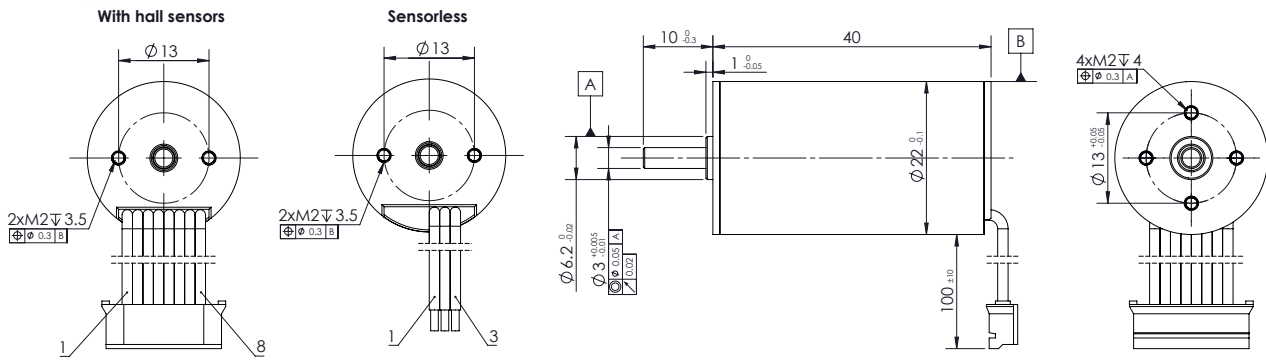

V 3

Values	Unit	SVTN A 01	2240-12..	2240-24..	2240-30..	2240-36..
Motor Data						
1	Nominal voltage	V	12	24	30	36
2	No load speed	rpm	16748	16768	16713	16679
3	No load current	mA	183	115	87	73
4	Nominal speed	rpm	14354	14337	14360	14128
5	Nominal torque	mNm	12	12	12	12
6	Nominal current	A	1,96	1,01	0,8	0,67
7	Stall torque	mNm	83,9	82,8	85,2	78,5
8	Stall current	A	12,6	6,28	5,15	3,95
9	Max. efficiency	%	77,4	74,8	75,7	74,7
Characteristics						
10	Terminal resistance*	Ω	0,95	3,82	5,83	9,11
11	Terminal inductance*	mH	0,07	0,28	0,44	0,64
12	Torque constant	mNm/A	6,74	13,4	16,9	20,2
13	Speed constant	rpm/V	1416	712	567	472
14	Speed/torque gradient	rpm/mNm	200	203	196	213
15	Mechanical time constant	ms	4,7	4,8	4,7	5,1
16	Rotor inertia	gcm ²	2,3	2,3	2,3	2,3
Mechanical data						
17	Thermal resistance housing-ambient	K/W	12,7			
18	Thermal resistance winding-housing	K/W	5,0			
19	Thermal time constant winding	s	12			
20	Thermal time constant motor	s	420			
21	Ambient temperature	°C	-30...+100			
22	Max. permissible winding temperature	°C	+150			
23	Max. permissible speed	rpm	35000			
24	Radial play		preloaded			
25	Max. axial load (dynamic)	N	3,5			
26	Max. force for press fits (static)	N	44			
27	Max. radial load, 5mm from flange	N	15			
Other specifications						
28	Number of poles		2			
29	Number of phases		3			
30	Weight	g	64			

*The diagram based on ambient temperature of 25°.

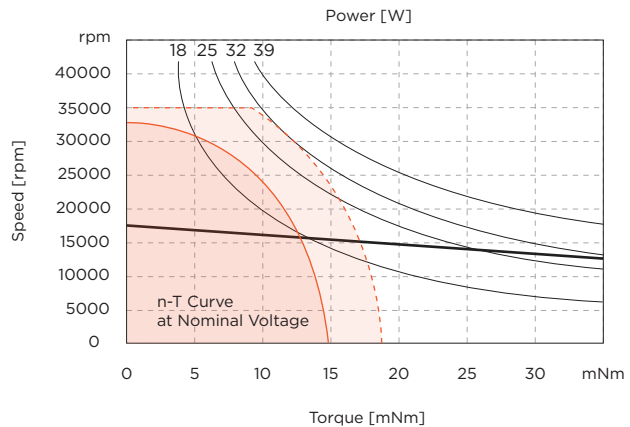

Continuous operating range
Continuous operating range with Reduced RtnZ 50%

Connection

Connection H (Sensor)	PVC
Pin 1	Vhall 3-18 VDC AWG26 black
Pin 2	Hall sensor HA AWG26 black
Pin 3	Hall sensor HB AWG26 black
Pin 4	Hall sensor HC AWG26 black
Pin 5	GND AWG26 black
Pin 6	Motor winding MA AWG26 black
Pin 7	Motor winding MB AWG26 black
Pin 8	Motor winding MC AWG26 black
Connector	
JST	PHR-8
Connection O (Sensorless)	
Pin 1	Motor winding MA AWG26 yellow
Pin 2	Motor winding MB AWG26 green
Pin 3	Motor winding MC AWG26 blue

Drive combinations

Hall sensors	Encoder
SVTE-A-E40	SVTE-A-E45
SVTE-A-E50	SVTE-A-E55

Encoder combinations

EN 22A
EN 22AL

Gearbox combinations

SVTG B 22
SVTG B 24



ATOM EC Series
SVTN A 01-2248

43 Watt



servotecnica
CORELESS
BRUSHLESS

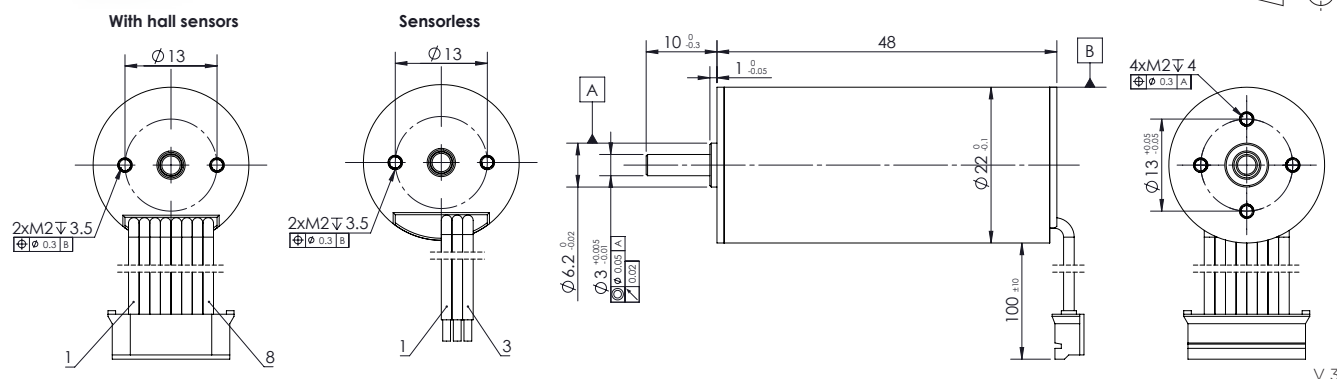

Values	Unit	SVTN A 01	2248-12..	2248-24..	2248-36..	2248-48..
--------	------	-----------	-----------	-----------	-----------	-----------

Motor Data						
1	Nominal voltage	V	12	24	36	48
2	No load speed	rpm	13004	12930	13390	13641
3	No load current	mA	179	102	82	69
4	Nominal speed	rpm	11426	11413	11749	12159
5	Nominal torque	mNm	18	18	18	18
6	Nominal current	A	2,24	1,13	0,79	0,61
7	Stall torque	mNm	148	153	147	166
8	Stall current	A	17,2	8,88	5,88	5,07
9	Max. efficiency	%	80,6	79,7	77,8	78

Characteristics						
10	Terminal resistance*	Ω	0,7	2,71	6,12	9,47
11	Terminal inductance*	mH	0,07	0,28	0,58	0,97
12	Torque constant	mNm/A	8,72	17,5	25,3	33,1
13	Speed constant	rpm/V	1095	545	377	288
14	Speed/torque gradient	rpm/mNm	87,7	84,3	91,2	82,3
15	Mechanical time constant	ms	2,9	2,8	3	2,7
16	Rotor inertia	gcm ²	3,1	3,1	3,1	3,1

Mechanical data		
17	Thermal resistance housing-ambient	11.8 K/W
18	Thermal resistance winding-housing	4.7 K/W
19	Thermal time constant winding	21 s
20	Thermal time constant motor	504 s
21	Ambient temperature	-30...+100°C
22	Max. permissible winding temperature	+150°C
23	Max. permissible speed	30000 rpm
24	Radial play	preloaded
25	Max. axial load (dynamic)	3.5 N
26	Max. force for press fits (static)	44 N
27	Max. radial load, 5mm from flange	15 N

Other specifications		
28	Number of poles	2
29	Number of phases	3
30	Weight	85 g

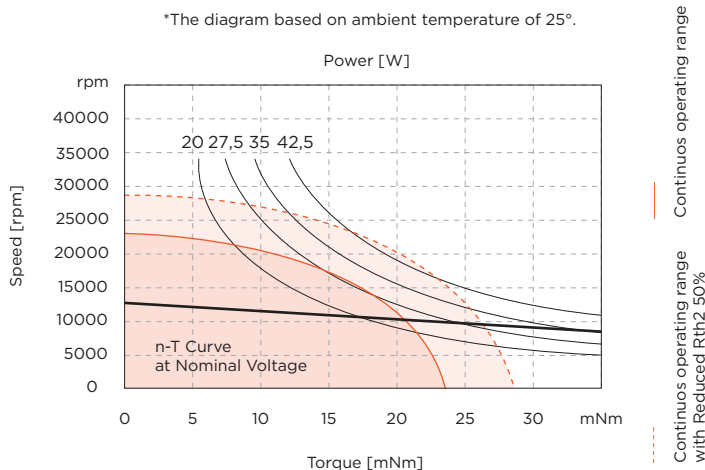

Connection

Connection H (Sensor)	PVC
Pin 1	Vhall 3-18 VDC
Pin 2	Hall sensor HA
Pin 3	Hall sensor HB
Pin 4	Hall sensor HC
Pin 5	GND
Pin 6	Motor winding MA
Pin 7	Motor winding MB
Pin 8	Motor winding MC

Connector
JST PHR-8

Connection O (Sensorless)	
Pin 1	Motor winding MA
Pin 2	Motor winding MB
Pin 3	Motor winding MC

Drive combinations

Hall sensors	Encoder
SVTE-A-E40	SVTE-A-E45
SVTE-A-E50	SVTE-A-E55

Encoder combinations

- EN 22A
- EN 22AL

Gearbox combinations

- SVTG B 22
- SVTG B 24



ATOM EC Series SVTN A 01-2260

70 Watt

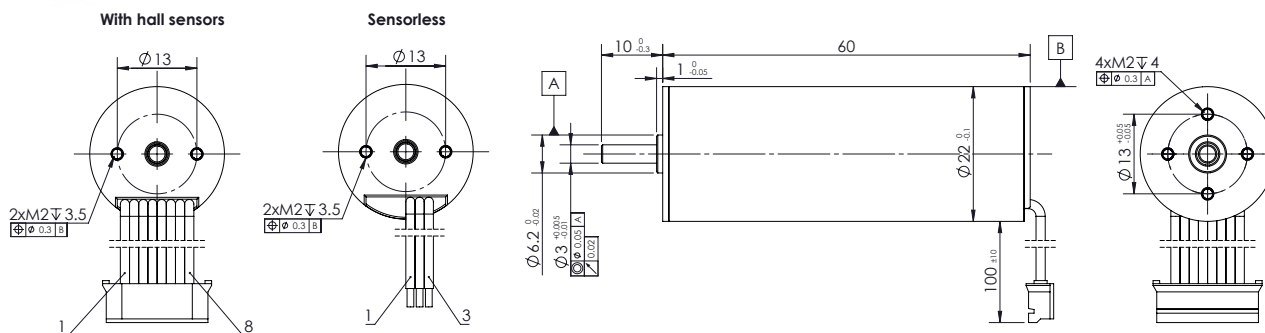

V 3

Values	Unit	SVTN A 01	2260-12..	2260-24..	2260-36..	2260-48..
Motor Data						
1	Nominal voltage	V	12	24	36	48
2	No load speed	rpm	16360	16086	16030	16200
3	No load current	mA	440	230	170	110
4	Nominal speed	rpm	14517	14441	14364	14530
5	Nominal torque	mNm	28	28	28	28
6	Nominal current	A	4,49	2,22	1,49	1,11
7	Stall torque	mNm	249	274	269	272
8	Stall current	A	36,4	19,7	12,9	9,82
9	Max. efficiency	%	79,2	79,5	78,4	79,9
Characteristics						
10	Terminal resistance*	Ω	0,33	1,22	2,79	4,89
11	Terminal inductance*	mH	0,03	0,13	0,3	0,52
12	Torque constant	mNm/A	6,92	14,1	21,2	28
13	Speed constant	rpm/V	1380	678	451	341
14	Speed/torque gradient	rpm/mNm	65,8	58,8	59,5	59,7
15	Mechanical time constant	ms	3,1	2,8	2,8	2,8
16	Rotor inertia	gcm ²	4,5	4,5	4,5	4,5
Mechanical data						
17	Thermal resistance housing-ambient	K/W	7,6			
18	Thermal resistance winding-housing	K/W	4,6			
19	Thermal time constant winding	s	29			
20	Thermal time constant motor	s	533			
21	Ambient temperature	°C	-30...+100			
22	Max. permissible winding temperature	°C	+150			
23	Max. permissible speed	rpm	30000			
24	Radial play		preloaded			
25	Max. axial load (dynamic)	N	3,5			
26	Max. force for press fits (static)	N	44			
27	Max. radial load, 5mm from flange	N	15			
Other specifications						
28	Number of poles		2			
29	Number of phases		3			
30	Weight	g	122			

*The diagram based on ambient temperature of 25°.

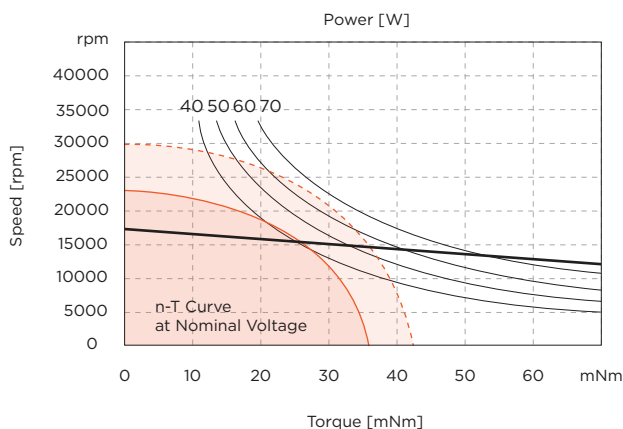

Continuous operating range
Continuous operating range with Reduced RtnZ 50%

Connection

Connection H (Sensor)	PVC		
Pin 1	Vhall 3-18 VDC	AWG26	black
Pin 2	Hall sensor HA	AWG26	black
Pin 3	Hall sensor HB	AWG26	black
Pin 4	Hall sensor HC	AWG26	black
Pin 5	GND	AWG26	black
Pin 6	Motor winding MA	AWG26	black
Pin 7	Motor winding MB	AWG26	black
Pin 8	Motor winding MC	AWG26	black
Connector			
JST	PHR-8		
Connection O (Sensorless)			
Pin 1	Motor winding MA	AWG26	yellow
Pin 2	Motor winding MB	AWG26	green
Pin 3	Motor winding MC	AWG26	blue

Drive combinations

Hall sensors	Encoder
SVTE-A-E40	SVTE-A-E45
SVTE-A-E50	SVTE-A-E55

Encoder combinations

EN 22A
EN 22AL

Gearbox combinations

SVTG B 22
SVTG B 24



ATOM EC Series
SVTN A 01-2446

42 Watt

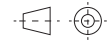

servotecnica
CORELESS
BRUSHLESS

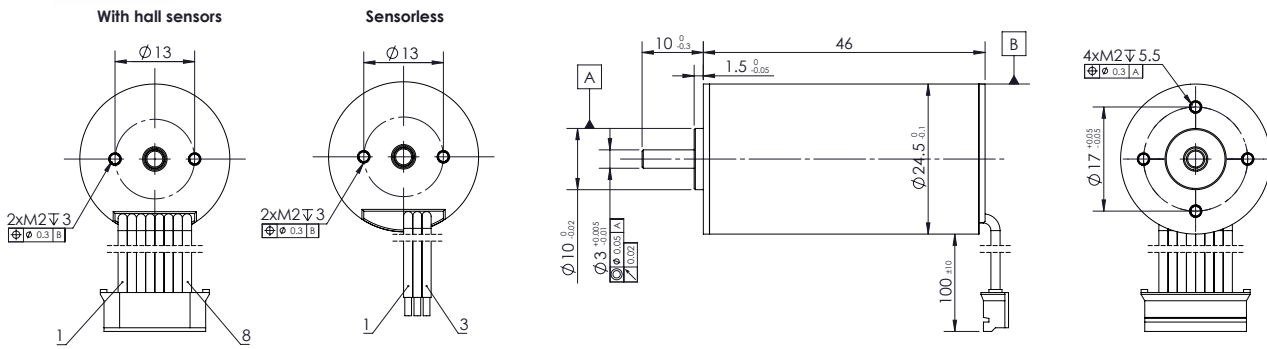

V 3

Values	Unit	SVTN A 01				
		2446-12..	2446-24..	2446-36..	2446-48..	
Motor Data						
1	Nominal voltage	V	12	24	36	48
2	No load speed	rpm	14150	13872	13920	13870
3	No load current	mA	249	124	106	79
4	Nominal speed	rpm	12678	12487	12662	12446
5	Nominal torque	mNm	18	18	18	18
6	Nominal current	A	2,5	1,23	0,84	0,63
7	Stall torque	mNm	173	180	199	175
8	Stall current	A	21,9	11,2	8,28	5,46
9	Max. efficiency	%	79,8	80	78,6	77,4
Characteristics						
10	Terminal resistance*	Ω	0,55	2,15	4,35	8,79
11	Terminal inductance*	mH	0,07	0,29	0,62	1,14
12	Torque constant	mNm/A	8,01	16,3	24,4	32,6
13	Speed constant	rpm/V	1193	584	392	293
14	Speed/torque gradient	rpm/mNm	81,8	76,9	69,9	79,1
15	Mechanical time constant	ms	3,6	3,4	3,1	3,5
16	Rotor inertia	gcm ²	4,2	4,2	4,2	4,2
Mechanical data						
17	Thermal resistance housing-ambient	K/W	11,6			
18	Thermal resistance winding-housing	K/W	5,6			
19	Thermal time constant winding	s	30			
20	Thermal time constant motor	s	557			
21	Ambient temperature	°C	-30...+100			
22	Max. permissible winding temperature	°C	+150			
23	Max. permissible speed	rpm	30000			
24	Radial play		preloaded			
25	Max. axial load (dynamic)	N	3,5			
26	Max. force for press fits (static)	N	44			
27	Max. radial load, 5mm from flange	N	15			
Other specifications						
28	Number of poles		2			
29	Number of phases		3			
30	Weight	g	92			

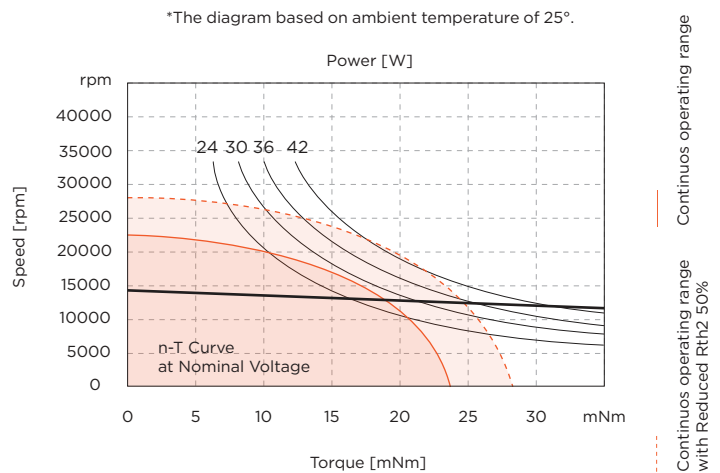

Connection

Connection H (Sensor)	PVC	Connection O (Sensorless)
Pin 1	Vhall 3-18 VDC	Motor winding MA
Pin 2	Hall sensor HA	Motor winding MB
Pin 3	Hall sensor HB	Motor winding MC
Pin 4	Hall sensor HC	
Pin 5	GND	
Pin 6	Motor winding MA	
Pin 7	Motor winding MB	
Pin 8	Motor winding MC	

Drive combinations

Hall sensors	Encoder
SVTE-A-E40	SVTE-A-E45
SVTE-A-E50	SVTE-A-E55

Encoder combinations

- EN 22A
- EN 22AL

Gearbox combinations

- SVTG B 24
- SVTG B 28



ATOM EC Series SVTN A 01-2453

54 Watt

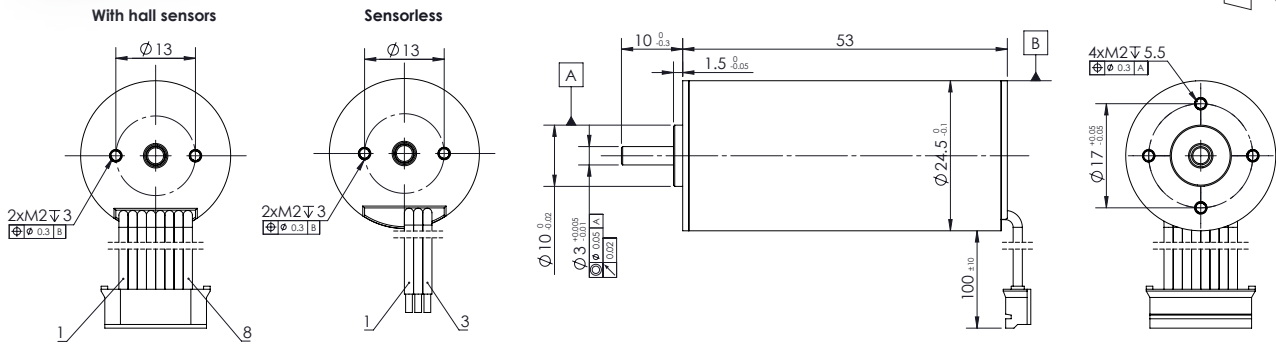

V 3

Values	Unit	SVTN A 01	2453-12..	2453-24..	2453-36..	2453-48..
--------	------	-----------	-----------	-----------	-----------	-----------

Motor Data						
1	Nominal voltage	V	12	24	36	48
2	No load speed	rpm	15083	15398	15202	15310
3	No load current	mA	308	156	115	94
4	Nominal speed	rpm	13938	14347	14211	14263
5	Nominal torque	mNm	20	20	20	20
6	Nominal current	A	2,96	1,51	1,01	0,77
7	Stall torque	mNm	263	293	307	293
8	Stall current	A	35,3	20	13,8	9,96
9	Max. efficiency	%	82,2	83,1	82,6	81,5
Characteristics						
10	Terminal resistance*	Ω	0,34	1,2	2,61	4,82
11	Terminal inductance*	mH	0,05	0,19	0,44	0,76
12	Torque constant	mNm/A	7,53	14,8	22,4	29,7
13	Speed constant	rpm/V	1268	647	426	322
14	Speed/torque gradient	rpm/mNm	57,2	52,5	49,6	52,3
15	Mechanical time constant	ms	3,5	3,2	3,1	3,2
16	Rotor inertia	gcm ²	5,9	5,9	5,9	5,9

Mechanical data		
17	Thermal resistance housing-ambient	10.2 K/W
18	Thermal resistance winding-housing	6.4 K/W
19	Thermal time constant winding	36 s
20	Thermal time constant motor	555 s
21	Ambient temperature	-30...+100°C
22	Max. permissible winding temperature	+150°C
23	Max. permissible speed	30000 rpm
24	Radial play	preloaded
25	Max. axial load (dynamic)	3.5 N
26	Max. force for press fits (static)	44 N
27	Max. radial load, 5mm from flange	15 N
Other specifications		
28	Number of poles	2
29	Number of phases	3
30	Weight	110 g

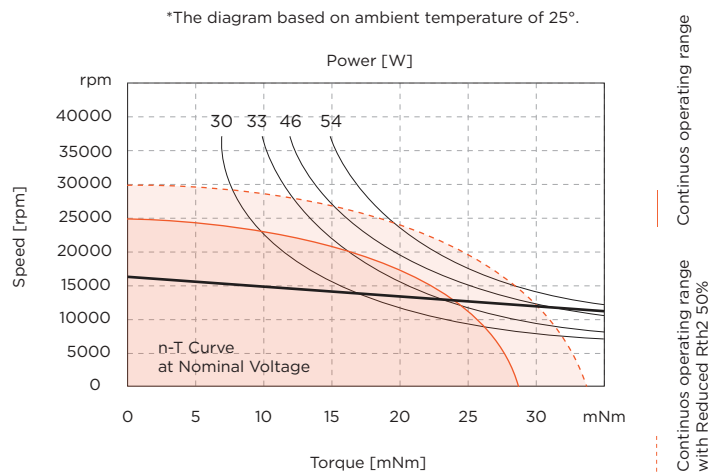

Connection

Connection H (Sensor)	PVC
Pin 1	Vhall 3-18 VDC
Pin 2	Hall sensor HA
Pin 3	Hall sensor HB
Pin 4	Hall sensor HC
Pin 5	GND
Pin 6	Motor winding MA
Pin 7	Motor winding MB
Pin 8	Motor winding MC

Connector
JST PHR-8

Connection O (Sensorless)	PVC
Pin 1	Motor winding MA
Pin 2	Motor winding MB
Pin 3	Motor winding MC

Drive combinations

Hall sensors	Encoder
SVTE-A-E40	SVTE-A-E45
SVTE-A-E50	SVTE-A-E55

Encoder combinations

EN 22A
EN 22AL

Gearbox combinations

SVTG B 22
SVTG B 24



ATOM EC Series
SVTN A 01-2845

35 Watt

servotecnica
CORELESS
BRUSHLESS

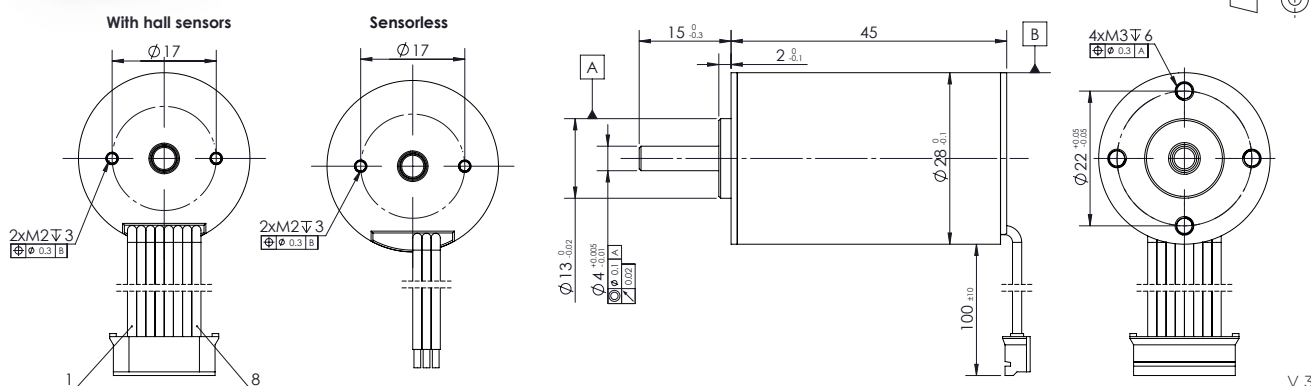

V 3

Values	Unit	SVTN A 01	2845-12..	2845-24..	2845-36..	2845-48..
--------	------	-----------	-----------	-----------	-----------	-----------

Motor Data						
1	Nominal voltage	V	12	24	36	48
2	No load speed	rpm	13737	13756	13783	13400
3	No load current	mA	202	128	84	79
4	Nominal speed	rpm	12232	12342	12432	11903
5	Nominal torque	mNm	18	18	18	18
6	Nominal current	A	2,38	1,22	0,81	0,61
7	Stall torque	mNm	164	175	184	161
8	Stall current	A	20,1	10,8	7,53	4,87
9	Max. efficiency	%	81	79,4	80	76,1
Characteristics						
10	Terminal resistance*	Ω	0,6	2,23	4,78	9,86
11	Terminal inductance*	mH	0,08	0,34	0,73	1,47
12	Torque constant	mNm/A	8,26	16,5	24,7	33,7
13	Speed constant	rpm/V	1156	580	387	284
14	Speed/torque gradient	rpm/mNm	83,6	78,6	75	83,1
15	Mechanical time constant	ms	4,5	4,3	4,1	4,5
16	Rotor inertia	gcm ²	5,2	5,2	5,2	5,2

Mechanical data		
17	Thermal resistance housing-ambient	9.6 K/W
18	Thermal resistance winding-housing	6.3 K/W
19	Thermal time constant winding	37 s
20	Thermal time constant motor	584 s
21	Ambient temperature	-30...+100°C
22	Max. permissible winding temperature	+150°C
23	Max. permissible speed	25000 rpm
24	Radial play	preloaded
25	Max. axial load (dynamic)	7.5 N
26	Max. force for press fits (static)	100 N
27	Max. radial load, 5mm from flange	25 N
Other specifications		
28	Number of poles	2
29	Number of phases	3
30	Weight	120 g

*The diagram based on ambient temperature of 25°.

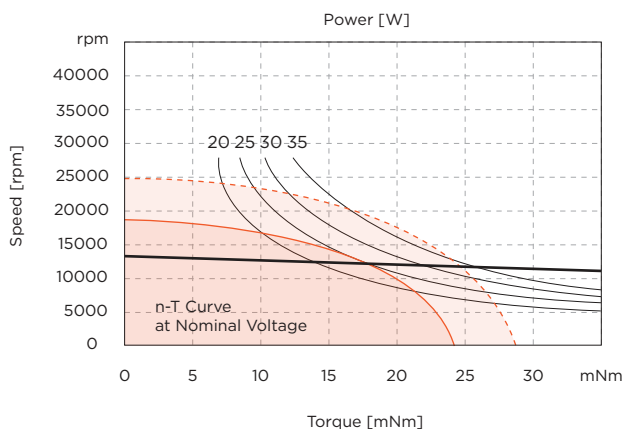

Continuous operating range
Continuous operating range with Reduced Rth2 50%

Connection

Connection H (Sensor)	PVC
Pin 1	Vhall 3-18 VDC
Pin 2	Hall sensor HA
Pin 3	Hall sensor HB
Pin 4	Hall sensor HC
Pin 5	GND
Pin 6	Motor winding MA
Pin 7	Motor winding MB
Pin 8	Motor winding MC

Connector
JST PHR-8

Connection O (Sensorless)	
Pin 1	Motor winding MA
Pin 2	Motor winding MB
Pin 3	Motor winding MC

Drive combinations

Hall sensors	Encoder
SVTE-A-E40	SVTE-A-E45
SVTE-A-E50	SVTE-A-E55

Encoder combinations

EN 22B
EN 22BL

Gearbox combinations

SVTGB 28



ATOM EC Series SVTN A 01-2854

72 Watt

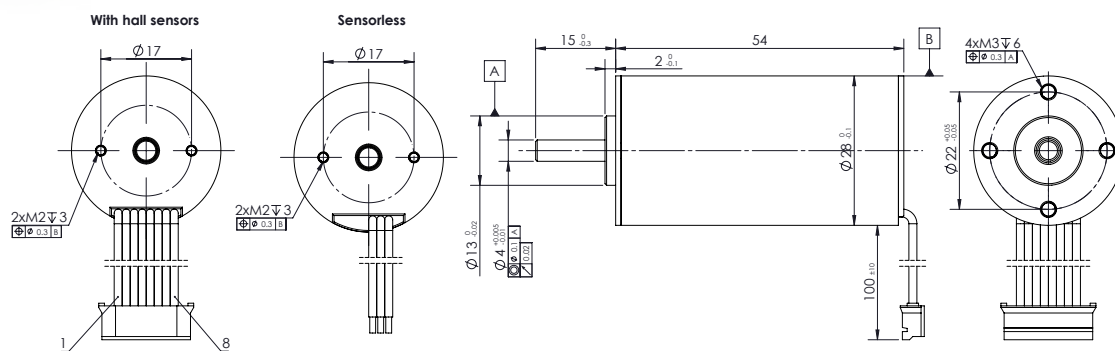

V 3

Values	Unit	SVTN A 01	2854-12..	2854-24..	2854-36..	2854-48..
Motor Data						
1	Nominal voltage	V	12	24	36	48
2	No load speed	rpm	8031	8336	8175	8325
3	No load current	mA	142	94	65	51
4	Nominal speed	rpm	6646	7084	6891	6805
5	Nominal torque	mNm	35	35	35	35
6	Nominal current	A	2,62	1,38	0,91	0,7
7	Stall torque	mNm	203	233	223	192
8	Stall current	A	14,5	8,66	5,43	3,58
9	Max. efficiency	%	81,2	80,3	79,3	77,6
Characteristics						
10	Terminal resistance*	Ω	0,83	2,77	6,63	13,4
11	Terminal inductance*	mH	0,16	0,61	1,41	2,56
12	Torque constant	mNm/A	14,1	27,2	41,5	54,3
13	Speed constant	rpm/V	676	351	230	176
14	Speed/torque gradient	rpm/mNm	39,6	35,8	36,7	43,4
15	Mechanical time constant	ms	3,5	3,2	3,3	3,9
16	Rotor inertia	gcm ²	8,5	8,5	8,5	8,5
Mechanical data						
17	Thermal resistance housing-ambient	K/W	7,1			
18	Thermal resistance winding-housing	K/W	5			
19	Thermal time constant winding	s	51			
20	Thermal time constant motor	s	552			
21	Ambient temperature	°C	-30...+100			
22	Max. permissible winding temperature	°C	+150			
23	Max. permissible speed	rpm	25000			
24	Radial play		preloaded			
25	Max. axial load (dynamic)	N	7,5			
26	Max. force for press fits (static)	N	100			
27	Max. radial load, 5mm from flange	N	25			
Other specifications						
28	Number of poles		2			
29	Number of phases		3			
30	Weight	g	156			

*The diagram based on ambient temperature of 25°.

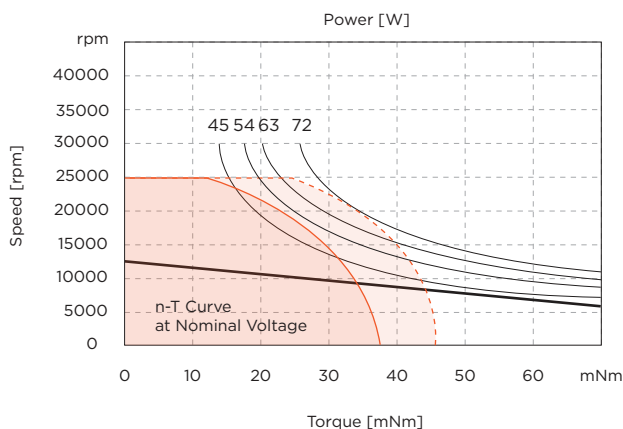

Continuous operating range
Continuous operating range with Reduced RTHZ 50%

Connection

Connection H (Sensor)	PVC
Pin 1	Vhall 3-18 VDC
Pin 2	Hall sensor HA
Pin 3	Hall sensor HB
Pin 4	Hall sensor HC
Pin 5	GND
Pin 6	Motor winding MA
Pin 7	Motor winding MB
Pin 8	Motor winding MC

Connector
JST PHR-8

Connection O (Sensorless)	
Pin 1	Motor winding MA
Pin 2	Motor winding MB
Pin 3	Motor winding MC

Drive combinations

Hall sensors	Encoder
SVTE-A-E40	SVTE-A-E45
SVTE-A-E50	SVTE-A-E55

Encoder combinations

EN 22B
EN 22BL

Gearbox combinations

SVTG B 28

88 Watt



ATOM EC Series
SVTN A 01-2864

servotecnica
CORELESS
BRUSHLESS

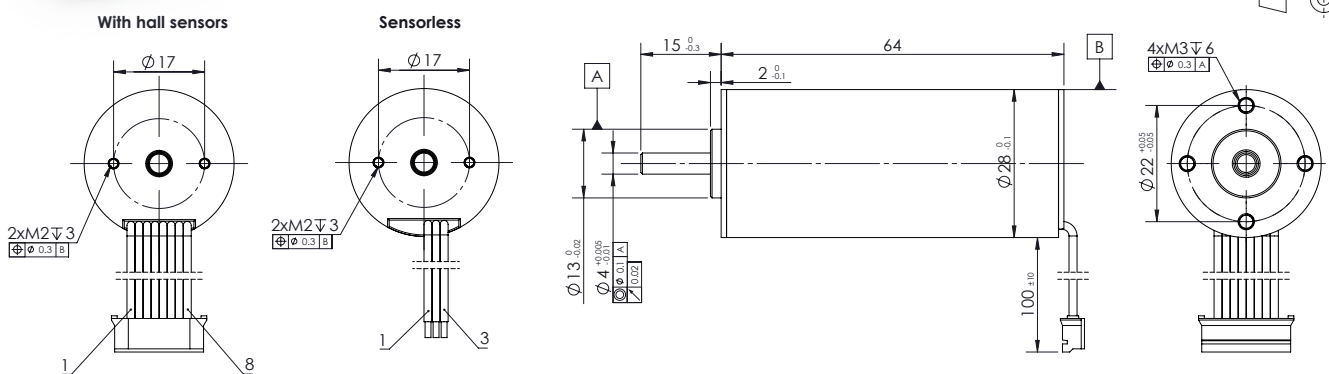

V 3

Values	Unit	SVTN A 01	2864-12..	2864-24..	2864-36..	2864-48..
--------	------	-----------	-----------	-----------	-----------	-----------

Motor Data						
1	Nominal voltage	V	12	24	36	48
2	No load speed	rpm	7956	8014	8275	7960
3	No load current	mA	182	104	92	59
4	Nominal speed	rpm	6712	6840	7053	6782
5	Nominal torque	mNm	50	50	50	50
6	Nominal current	A	3,68	1,87	1,31	0,94
7	Stall torque	mNm	320	341	339	338
8	Stall current	A	22,6	12,1	8,33	5,99
9	Max. efficiency	%	82,8	82,3	80,1	81,1
Characteristics						
10	Terminal resistance*	Ω	0,53	1,98	4,32	8,02
11	Terminal inductance*	mH	0,11	0,46	0,96	1,83
12	Torque constant	mNm/A	14,3	14,3	14,3	14,3
13	Speed constant	rpm/V	668	337	232	167
14	Speed/torque gradient	rpm/mNm	24,9	23,5	24,4	23,6
15	Mechanical time constant	ms	2,5	2,4	2,5	2,4
16	Rotor inertia	gcm ²	9,6	9,6	9,6	9,6

Mechanical data		
17	Thermal resistance housing-ambient	5.5 K/W
18	Thermal resistance winding-housing	4 K/W
19	Thermal time constant winding	56 s
20	Thermal time constant motor	521 s
21	Ambient temperature	-30...+100°C
22	Max. permissible winding temperature	+150°C
23	Max. permissible speed	25000 rpm
24	Radial play	preloaded
25	Max. axial load (dynamic)	7.5 N
26	Max. force for press fits (static)	100 N
27	Max. radial load, 5mm from flange	25 N
Other specifications		
28	Number of poles	2
29	Number of phases	3
30	Weight	195 g

*The diagram based on ambient temperature of 25°.

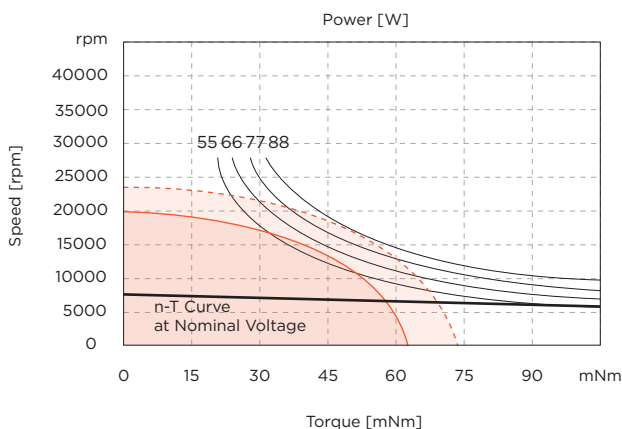

Continuous operating range
Continuous operating range with Reduced RtnZ 50%

Connection

Connection H (Sensor)			
Connection H	(Sensor)	PVC	
Pin 1	Vhall 3-18 VDC	AWG26	black
Pin 2	Hall sensor HA	AWG26	black
Pin 3	Hall sensor HB	AWG26	black
Pin 4	Hall sensor HC	AWG26	black
Pin 5	GND	AWG26	black
Pin 6	Motor winding MA	AWG26	black
Pin 7	Motor winding MB	AWG26	black
Pin 8	Motor winding MC	AWG26	black
Connector			
JST	PHR-8		
Connection O (Sensorless)			
Pin 1	Motor winding MA	AWG26	yellow
Pin 2	Motor winding MB	AWG26	green
Pin 3	Motor winding MC	AWG26	blue

Drive combinations

Hall sensors	Encoder
SVTE-A-E40	SVTE-A-E45
SVTE-A-E50	SVTE-A-E55

Encoder combinations

EN 22B
EN 22BL

Gearbox combinations

SVTG B 28

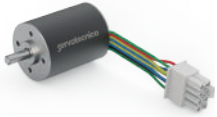

ATOM EC Series SVTN A 01-3242

60 Watt

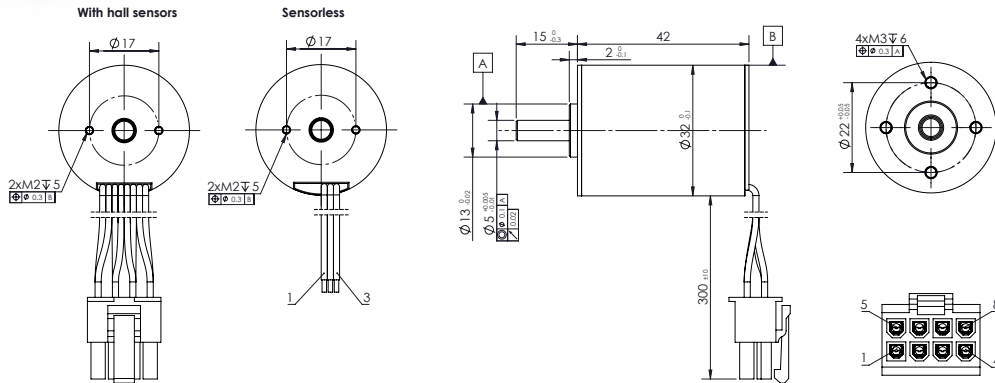
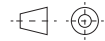

V 3

Values	Unit	SVTN A 01	3242-12..	3242-24..	3242-36..	3242-48..
Motor Data						
1	Nominal voltage	V	12	24	36	48
2	No load speed	rpm	9300	9500	9000	9300
3	No load current	mA	370	190	120	90
4	Nominal speed	rpm	7979	8227	7848	8035
5	Nominal torque	mNm	22,3	24,5	21,8	27,8
6	Nominal current	A	2,23	1,23	0,83	0,58
7	Stall torque	mNm	157	183	206	173
8	Stall current	A	13,5	7,95	5,64	3,68
9	Max. efficiency	%	69,6	71,4	72,9	71,1
Characteristics						
10	Terminal resistance*	Ω	0,89	3,02	6,38	13,04
11	Terminal inductance*	mH	0,08	0,26	0,61	1,05
12	Torque constant	mNm/A	12	23,5	37,4	48,1
13	Speed constant	rpm/V	797	406	256	199
14	Speed/torque gradient	rpm/mNm	59,2	52	46,8	53,9
15	Mechanical time constant	ms	5,8	5,1	4,6	5,3
16	Rotor inertia	gcm ²	9,4	9,4	9,4	9,4
Mechanical data						
17	Thermal resistance housing-ambient	8.8 K/W				
18	Thermal resistance winding-housing	2.7 K/W				
19	Thermal time constant winding	23.5 s				
20	Thermal time constant motor	560 s				
21	Ambient temperature	-30...+100°C				
22	Max. permissible winding temperature	+150°C				
23	Max. permissible speed	25000 rpm				
24	Radial play	preloaded				
25	Max. axial load (dynamic)	7.5 N				
26	Max. force for press fits (static)	100 N				
27	Max. radial load, 5mm from flange	25 N				
Other specifications						
28	Number of poles	2				
29	Number of phases	3				
30	Weight	147 g				

*The diagram based on ambient temperature of 25°.

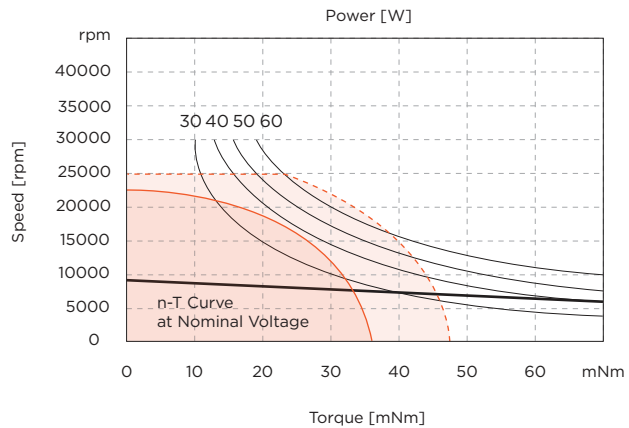

Continuous operating range
Continuous operating range with Reduced Rtn2 50%

Connection

Connection H (Sensor)	PTFE		
Pin 1	Motor winding MB	AWG20	green
Pin 2	Vhall 3-18 VDC	AWG26	red
Pin 3	Hall sensor HA	AWG26	yellow
Pin 4	Hall sensor HC	AWG26	blue
Pin 5	Motor winding MA	AWG20	yellow
Pin 6	Motor winding MC	AWG20	blue
Pin 7	GND	AWG26	black
Pin 8	Hall sensor HB	AWG26	green

Connector
Molex 39-01-2080

Connection O (Sensorless)	PTFE		
Pin 1	Motor winding MA	AWG20	yellow
Pin 2	Motor winding MB	AWG20	green
Pin 3	Motor winding MC	AWG20	blue

Drive combinations

Hall sensors	Encoder
SVTE-A-E40	SVTE-A-E45
SVTE-A-E50	SVTE-A-E55

Encoder combinations

EN 22B
EN 22BL

Gearbox combinations

SVTG B 32
SVTG B 36



ATOM EC Series
SVTN A 01-3260

120 Watt



servotecnica
CORELESS
BRUSHLESS

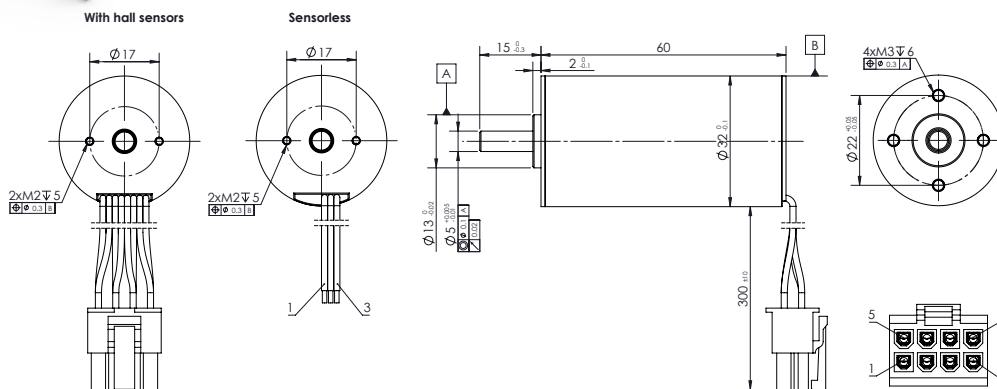

V 3

Values	Unit	SVTN A 01 3260-12..	3260-24..	3260-36..	3260-48..
--------	------	------------------------	-----------	-----------	-----------

Motor Data						
1	Nominal voltage	V	12	24	36	48
2	No load speed	rpm	10845	11038	10937	11125
3	No load current	mA	430	190	130	90
4	Nominal speed	rpm	9889	10027	9931	10087
5	Nominal torque	mNm	50	50	50	50
6	Nominal current	A	5,2	2,62	1,73	1,31
7	Stall torque	mNm	567	546	544	536
8	Stall current	A	54,5	26,7	17,6	13,2
9	Max. efficiency	%	83	83,8	83,5	84,2
Characteristics						
10	Terminal resistance*	Ω	0,2	0,9	2,05	3,64
11	Terminal inductance*	mH	0,08	0,32	0,9	1,22
12	Torque constant	mNm/A	10,5	20,6	31,2	40,9
13	Speed constant	rpm/V	911	463	306	233
14	Speed/torque gradient	rpm/mNm	19,1	20,2	20,1	20,8
15	Mechanical time constant	ms	3,1	3,3	3,3	3,4
16	Rotor inertia	gcm ²	15,5	15,5	15,5	15,5

Mechanical data		
17	Thermal resistance housing-ambient	6 K/W
18	Thermal resistance winding-housing	3.2 K/W
19	Thermal time constant winding	36 s
20	Thermal time constant motor	626 s
21	Ambient temperature	-30...+100°C
22	Max. permissible winding temperature	+150°C
23	Max. permissible speed	25000 rpm
24	Radial play	preloaded
25	Max. axial load (dynamic)	7.5 N
26	Max. force for press fits (static)	100 N
27	Max. radial load, 5mm from flange	25 N
Other specifications		
28	Number of poles	2
29	Number of phases	3
30	Weight	217 g

*The diagram based on ambient temperature of 25°.

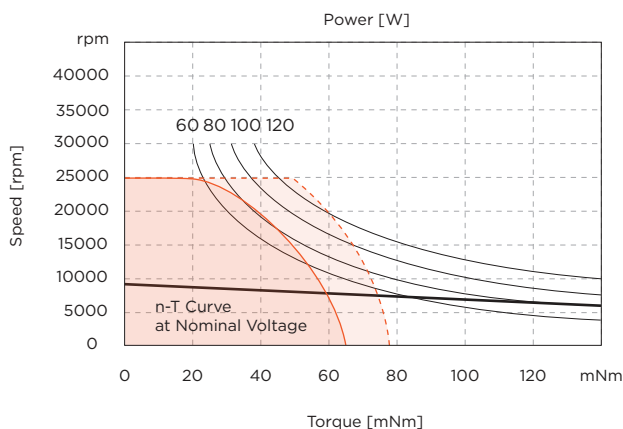

Continuous operating range
Continuous operating range with Reduced RtnZ 50%

Connection

Connection H (Sensor)			
Connection H	(Sensor)	PTFE	
Pin 1	Motor winding MB	AWG20	green
Pin 2	Vhall 3-18 VDC	AWG26	red
Pin 3	Hall sensor HA	AWG26	yellow
Pin 4	Hall sensor HC	AWG26	blue
Pin 5	Motor winding MA	AWG20	yellow
Pin 6	Motor winding MC	AWG20	blue
Pin 7	GND	AWG26	black
Pin 8	Hall sensor HB	AWG26	green
Connector			
Molex	39-01-2080		
Connection O (Sensorless)			
Connection O	(Sensorless)	PTFE	
Pin 1	Motor winding MA	AWG20	yellow
Pin 2	Motor winding MB	AWG20	green
Pin 3	Motor winding MC	AWG20	blue

Drive combinations

Hall sensors	Encoder
SVTE-A-E40	SVTE-A-E45
SVTE-A-E50	SVTE-A-E55

Encoder combinations

EN 22B
EN 22BL

Gearbox combinations

SVTG B 32
SVTG B 36



ATOM EC Series SVTN A 01-3270

130 Watt

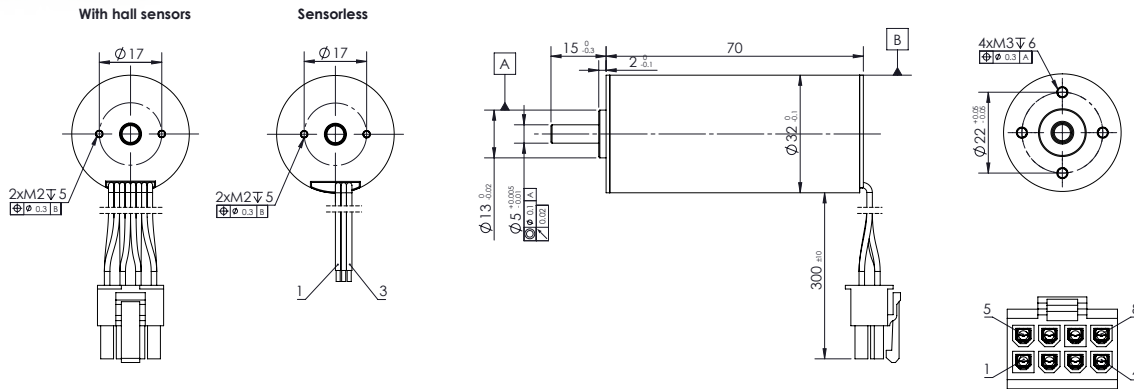

V 3

Values	Unit	SVTN A 01	3270-12..	3270-24..	3270-36..	3270-48..
Motor Data						
1	Nominal voltage	V	12	24	36	48
2	No load speed	rpm	8998	9055	9252	9080
3	No load current	mA	450	180	100	90
4	Nominal speed	rpm	7991	7963	8129	8077
5	Nominal torque	mNm	70	70	70	70
6	Nominal current	A	6	2,97	2	1,49
7	Stall torque	mNm	625	581	577	634
8	Stall current	A	50	23,3	15,7	12,7
9	Max. efficiency	%	81,9	83,2	84,7	83,9
Characteristics						
10	Terminal resistance*	Ω	0,24	1,03	2,29	3,77
11	Terminal inductance*	mH	0,09	0,35	0,75	1,33
12	Torque constant	mNm/A	12,6	25,1	36,9	50,1
13	Speed constant	rpm/V	757	380	259	191
14	Speed/torque gradient	rpm/mNm	14,4	15,6	16	14,3
15	Mechanical time constant	ms	2,8	3	3,1	2,8
16	Rotor inertia	gcm ²	18,5	18,5	18,5	18,5
Mechanical data						
17	Thermal resistance housing-ambient	K/W	4,7			
18	Thermal resistance winding-housing	K/W	2,9			
19	Thermal time constant winding	s	38			
20	Thermal time constant motor	s	568			
21	Ambient temperature	°C	-30...+100			
22	Max. permissible winding temperature	°C	+150			
23	Max. permissible speed	rpm	25000			
24	Radial play		preloaded			
25	Max. axial load (dynamic)	N	7,5			
26	Max. force for press fits (static)	N	100			
27	Max. radial load, 5mm from flange	N	25			
Other specifications						
28	Number of poles		2			
29	Number of phases		3			
30	Weight	g	256			

*The diagram based on ambient temperature of 25°.

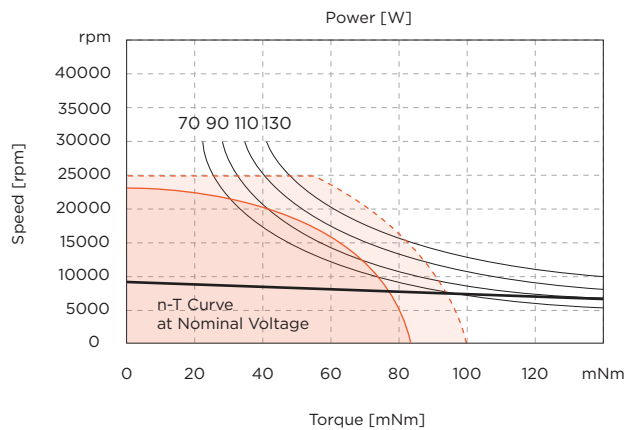

Continuous operating range
Continuous operating range with Reduced Rth2 50%

Connection

Connection H (Sensor)	Material	Wire Gauge	Color
Pin 1	Motor winding MB	AWG20	green
Pin 2	Vhall 3-18 VDC	AWG26	red
Pin 3	Hall sensor HA	AWG26	yellow
Pin 4	Hall sensor HC	AWG26	blue
Pin 5	Motor winding MA	AWG20	yellow
Pin 6	Motor winding MC	AWG20	blue
Pin 7	GND	AWG26	black
Pin 8	Hall sensor HB	AWG26	green

Connector: Molex 39-01-2080

Connection O (Sensorless)	Material	Wire Gauge	Color
Pin 1	Motor winding MA	AWG20	yellow
Pin 2	Motor winding MB	AWG20	green
Pin 3	Motor winding MC	AWG20	blue

Drive combinations

Hall sensors	Encoder
SVTE-A-E40	SVTE-A-E45
SVTE-A-E50	SVTE-A-E55

Encoder combinations

EN 22B
EN 22BL

Gearbox combinations

SVTG B 32
SVTG B 36



ATOM EC Series
SVTN A 01-3660

140 Watt

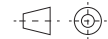

servotecnica
CORELESS
BRUSHLESS

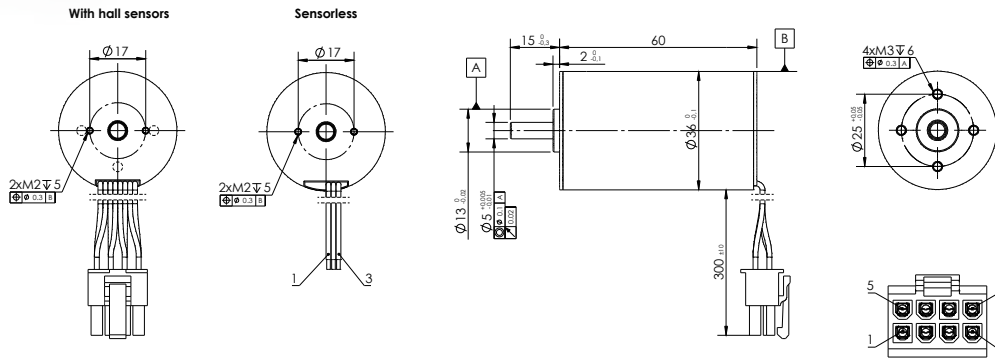

V 3

Values	Unit	SVTN A 01 3660-12..	3660-24..	3660-36..	3660-48..	
Motor Data						
1	Nominal voltage	V	12	24	36	48
2	No load speed	rpm	8050	8140	8014	8083
3	No load current	mA	288	148	101	84
4	Nominal speed	rpm	6794	6784	6804	6766
5	Nominal torque	mNm	82	82	82	82
6	Nominal current	A	6,09	3,08	2,03	1,54
7	Stall torque	mNm	526	492	543	503
8	Stall current	A	37,5	17,8	12,9	9,04
9	Max. efficiency	%	83,2	82,6	83,1	81,6
Characteristics						
10	Terminal resistance*	Ω	0,32	1,35	2,8	5,31
11	Terminal inductance*	mH	0,09	0,38	0,88	1,6
12	Torque constant	mNm/A	14,1	27,9	42,6	56,2
13	Speed constant	rpm/V	676	342	224	170
14	Speed/torque gradient	rpm/mNm	15,3	16,5	14,8	16,1
15	Mechanical time constant	ms	3,1	3,4	3	3,3
16	Rotor inertia	gcm ²	19,5	19,5	19,5	19,5
Mechanical data						
17	Thermal resistance housing-ambient	K/W	4,4			
18	Thermal resistance winding-housing	K/W	1,3			
19	Thermal time constant winding	s	15			
20	Thermal time constant motor	s	582			
21	Ambient temperature	°C	-30...+100			
22	Max. permissible winding temperature	°C	+150			
23	Max. permissible speed	rpm	20000			
24	Radial play		preloaded			
25	Max. axial load (dynamic)	N	7,5			
26	Max. force for press fits (static)	N	100			
27	Max. radial load, 5mm from flange	N	25			
Other specifications						
28	Number of poles		2			
29	Number of phases		3			
30	Weight	g	272			

*The diagram based on ambient temperature of 25°.

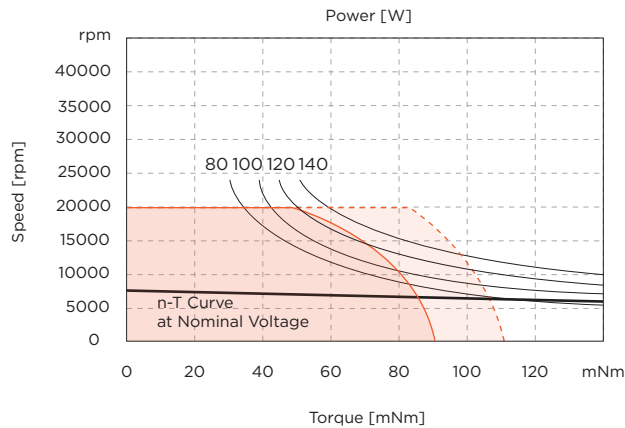

Continuous operating range
Continuous operating range with Reduced RtnZ 50%

Connection

Connection H (Sensor)	Material	Wire Gauge	Color
Pin 1	Motor winding MB	AWG20	green
Pin 2	Vhall 3-18 VDC	AWG26	red
Pin 3	Hall sensor HA	AWG26	yellow
Pin 4	Hall sensor HC	AWG26	blue
Pin 5	Motor winding MA	AWG20	yellow
Pin 6	Motor winding MC	AWG20	blue
Pin 7	GND	AWG26	black
Pin 8	Hall sensor HB	AWG26	green

Connector: Molex 39-01-2080

Connection O (Sensorless)	Material	Wire Gauge	Color
Pin 1	Motor winding MA	AWG20	yellow
Pin 2	Motor winding MB	AWG20	green
Pin 3	Motor winding MC	AWG20	blue

Drive combinations

Hall sensors	Encoder
SVTE-A-E40	SVTE-A-E45
SVTE-A-E50	SVTE-A-E55

Encoder combinations

EN 22B
EN 22BL

Gearbox combinations

SVTG B 36
SVTG B 42



ATOM EC Series SVTN A 01-3670

250 Watt

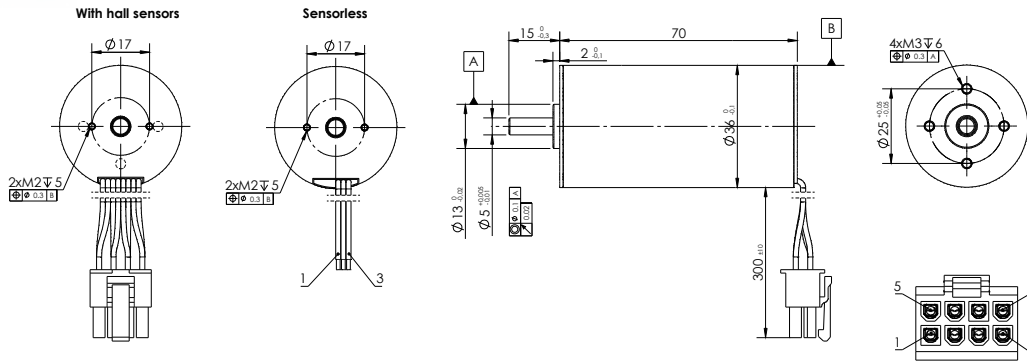
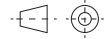

V 3

Values	Unit	SVTN A 01	3670-12..	3670-24..	3670-36..	3670-48..
Motor Data						
1	Nominal voltage	V	12	24	36	48
2	No load speed	rpm	6578	6555	6675	6545
3	No load current	mA	293	137	101	78
4	Nominal speed	rpm	5300	5391	5455	5401
5	Nominal torque	mNm	120	120	120	120
6	Nominal current	A	7,24	3,59	2,45	1,81
7	Stall torque	mNm	618	676	657	687
8	Stall current	A	36	19,6	12,9	9,96
9	Max. efficiency	%	82,8	84	83,1	83,1
Characteristics						
10	Terminal resistance*	Ω	0,33	1,22	2,78	4,82
11	Terminal inductance*	mH	0,09	0,38	0,85	1,52
12	Torque constant	mNm/A	17,3	34,7	51,1	69,5
13	Speed constant	rpm/V	553	275	187	137
14	Speed/torque gradient	rpm/mNm	10,7	9,7	10,2	9,5
15	Mechanical time constant	ms	2,4	2,2	2,3	2,1
16	Rotor inertia	gcm ²	21,5	21,5	21,5	21,5
Mechanical data						
17	Thermal resistance housing-ambient	K/W	3,5			
18	Thermal resistance winding-housing	K/W	0,9			
19	Thermal time constant winding	s	14,3			
20	Thermal time constant motor	s	558			
21	Ambient temperature	°C	-30...+100			
22	Max. permissible winding temperature	°C	+150			
23	Max. permissible speed	rpm	20000			
24	Radial play		preloaded			
25	Max. axial load (dynamic)	N	7,5			
26	Max. force for press fits (static)	N	100			
27	Max. radial load, 5mm from flange	N	25			
Other specifications						
28	Number of poles		2			
29	Number of phases		3			
30	Weight	g	331			

*The diagram based on ambient temperature of 25°.

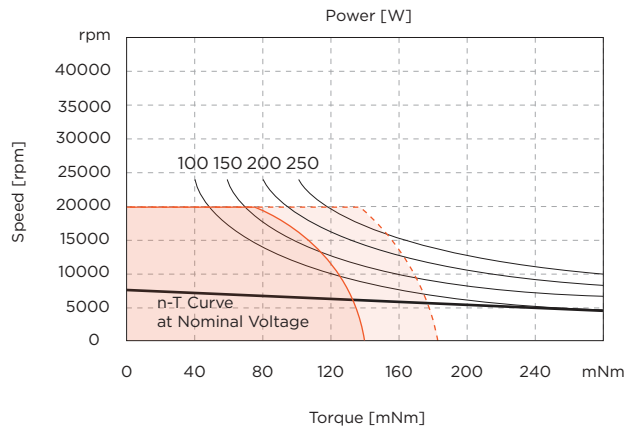

Continuous operating range
Continuous operating range with Reduced Rtn 50%

Connection

Connection H (Sensor)	Material	Wire Gauge	Color
Pin 1	Motor winding MB	AWG20	green
Pin 2	Vhall 3-18 VDC	AWG26	red
Pin 3	Hall sensor HA	AWG26	yellow
Pin 4	Hall sensor HC	AWG26	blue
Pin 5	Motor winding MA	AWG20	yellow
Pin 6	Motor winding MC	AWG20	blue
Pin 7	GND	AWG26	black
Pin 8	Hall sensor HB	AWG26	green

Connector: Molex 39-01-2080

Connection O (Sensorless)	Material	Wire Gauge	Color
Pin 1	Motor winding MA	AWG20	yellow
Pin 2	Motor winding MB	AWG20	green
Pin 3	Motor winding MC	AWG20	blue

Drive combinations

Hall sensors	Encoder
SVTE-A-E40	SVTE-A-E45
SVTE-A-E50	SVTE-A-E55

Encoder combinations

EN 22B
EN 22BL

Gearbox combinations

SVTG B 36
SVTG B 42

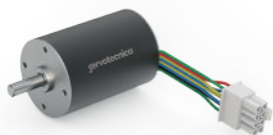

ATOM EC Series
SVTN A 01-4058

150 Watt



servotecnica
CORELESS
BRUSHLESS

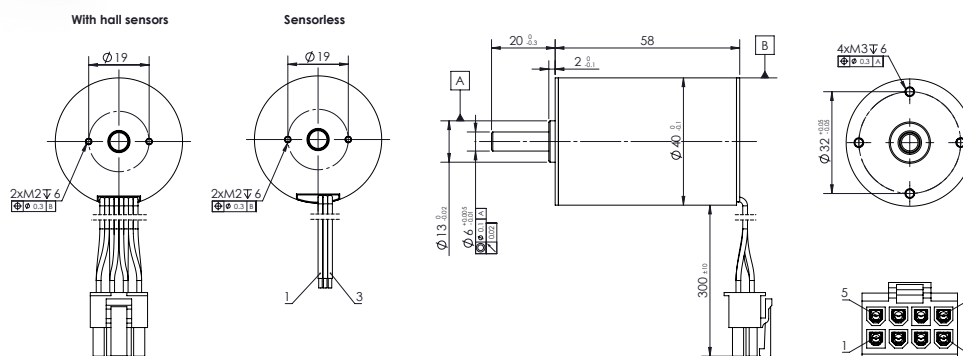

V 3

Values	Unit	SVTN A 01 4058-12..	4058-24..	4058-36..	4058-48..	
Motor Data						
1	Nominal voltage	V	12	24	36	48
2	No load speed	rpm	7958	7890	7962	8001
3	No load current	mA	480	200	170	110
4	Nominal speed	rpm	7000	6912	6943	6986
5	Nominal torque	mNm	85	85	85	85
6	Nominal current	A	6,44	3,15	2,16	1,61
7	Stall torque	mNm	706	686	664	670
8	Stall current	A	50	24	15,7	11,9
9	Max. efficiency	%	81,4	82,6	80,3	81,7
Characteristics						
10	Terminal resistance*	Ω	0,24	1	2,29	4,03
11	Terminal inductance*	mH	0,11	0,46	0,97	1,67
12	Torque constant	mNm/A	14,3	28,8	42,7	56,8
13	Speed constant	rpm/V	670	332	224	168
14	Speed/torque gradient	rpm/mNm	11,3	11,5	12	11,9
15	Mechanical time constant	ms	3,5	3,6	3,7	3,7
16	Rotor inertia	gcm ²	29,6	29,6	29,6	29,6
Mechanical data						
17	Thermal resistance housing-ambient	K/W	4,7			
18	Thermal resistance winding-housing	K/W	2,2			
19	Thermal time constant winding	s	35			
20	Thermal time constant motor	s	777			
21	Ambient temperature	°C	-30...+100			
22	Max. permissible winding temperature	°C	+150			
23	Max. permissible speed	rpm	17500			
24	Radial play		preloaded			
25	Max. axial load (dynamic)	N	9			
26	Max. force for press fits (static)	N	170			
27	Max. radial load, 5mm from flange	N	80			
Other specifications						
28	Number of poles		2			
29	Number of phases		3			
30	Weight	g	338			

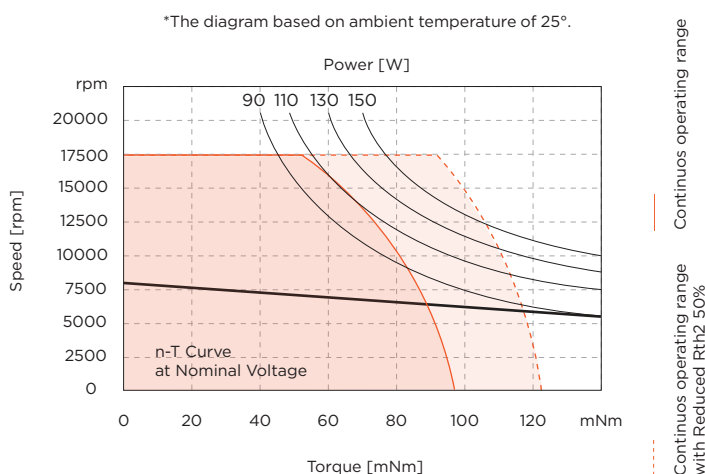

Connection

Connection H (Sensor)	Material	Wire	Color
Pin 1	Motor winding MB	AWG20	green
Pin 2	Vhall 3-18 VDC	AWG26	red
Pin 3	Hall sensor HA	AWG26	yellow
Pin 4	Hall sensor HC	AWG26	blue
Pin 5	Motor winding MA	AWG20	yellow
Pin 6	Motor winding MC	AWG20	blue
Pin 7	GND	AWG26	black
Pin 8	Hall sensor HB	AWG26	green

Connector: Molex 39-01-2080

Connection O (Sensorless)	Material	Wire	Color
Pin 1	Motor winding MA	AWG20	yellow
Pin 2	Motor winding MB	AWG20	green
Pin 3	Motor winding MC	AWG20	blue

Drive combinations

Hall sensors	Encoder
SVTE-A-E40	SVTE-A-E45
SVTE-A-E50	SVTE-A-E55

Encoder combinations

EN 24
EN 24L

Gearbox combinations

SVTG B 42



ATOM EC Series SVTN A 01-4070

210 Watt

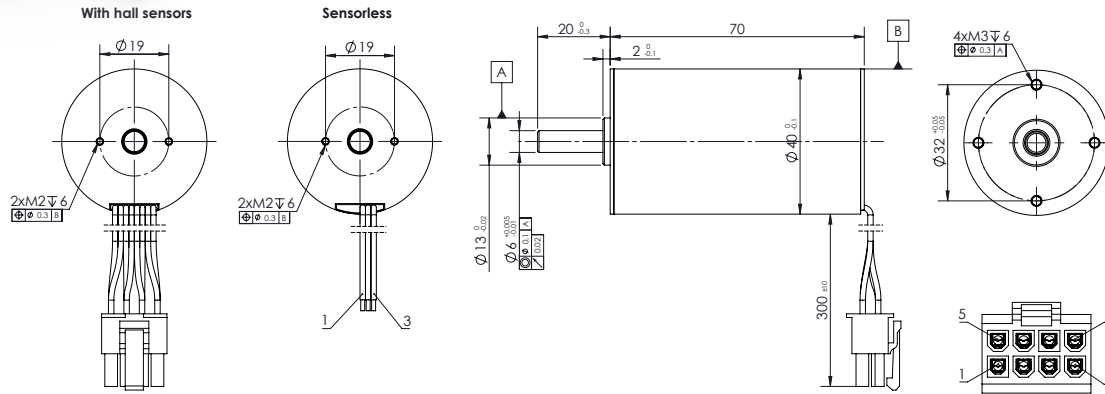

V 3

Values	Unit	SVTN A 01 4070-12..	4070-24..	4070-36..	4070-48..	
Motor Data						
1	Nominal voltage	V	12	24	36	48
2	No load speed	rpm	6154	8102	8113	8061
3	No load current	mA	264	200	190	130
4	Nominal speed	rpm	5084	7304	7266	7238
5	Nominal torque	mNm	130	130	130	130
6	Nominal current	A	7,29	4,82	3,28	2,43
7	Stall torque	mNm	748	1320	1245	1273
8	Stall current	A	40,7	47,1	29,8	22,6
9	Max. efficiency	%	84,5	87,4	84,7	85,4
Characteristics						
10	Terminal resistance*	Ω	0,3	0,51	1,21	2,12
11	Terminal inductance*	mH	0,11	0,3	0,66	1,2
12	Torque constant	mNm/A	18,5	28,2	42,1	56,5
13	Speed constant	rpm/V	516	339	227	169
14	Speed/torque gradient	rpm/mNm	8,23	6,14	6,52	6,33
15	Mechanical time constant	ms	3,4	2,5	2,7	2,6
16	Rotor inertia	gcm ²	39,4	39,4	39,4	39,4
Mechanical data						
17	Thermal resistance housing-ambient		3.8 K/W			
18	Thermal resistance winding-housing		1.5 K/W			
19	Thermal time constant winding		33 s			
20	Thermal time constant motor		775 s			
21	Ambient temperature		-30...+100°C			
22	Max. permissible winding temperature		+150°C			
23	Max. permissible speed		17500 rpm			
24	Radial play		preloaded			
25	Max. axial load (dynamic)		9 N			
26	Max. force for press fits (static)		170 N			
27	Max. radial load, 5mm from flange		80 N			
Other specifications						
28	Number of poles		2			
29	Number of phases		3			
30	Weight		415 g			

*The diagram based on ambient temperature of 25°.

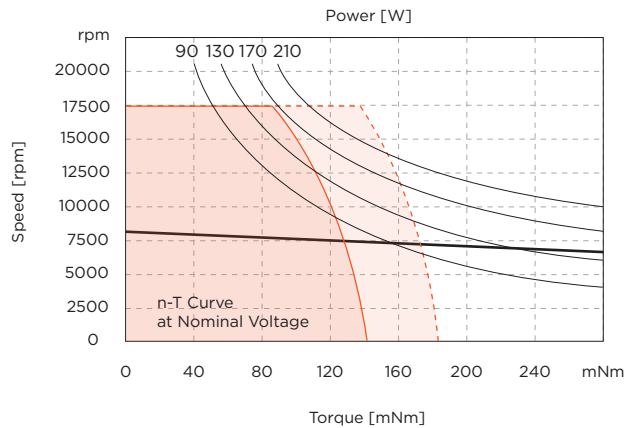

Continuous operating range
Continuous operating range with Reduced RtnZ 50%

Connection

Connection H (Sensor)		PTFE	
Pin 1	Motor winding MB	AWG20	green
Pin 2	Vhall 3-18 VDC	AWG26	red
Pin 3	Hall sensor HA	AWG26	yellow
Pin 4	Hall sensor HC	AWG26	blue
Pin 5	Motor winding MA	AWG20	yellow
Pin 6	Motor winding MC	AWG20	blue
Pin 7	GND	AWG26	black
Pin 8	Hall sensor HB	AWG26	green
Connector			
Molex	39-01-2080		
Connection O (Sensorless)		PTFE	
Pin 1	Motor winding MA	AWG20	yellow
Pin 2	Motor winding MB	AWG20	green
Pin 3	Motor winding MC	AWG20	blue

Drive combinations

Hall sensors	Encoder
SVTE-A-E40	SVTE-A-E45
SVTE-A-E50	SVTE-A-E55

Encoder combinations

EN 24
EN 24L

Gearbox combinations

SVTG B 42



ATOM EC Series
SVTN A 01-4088

400 Watt

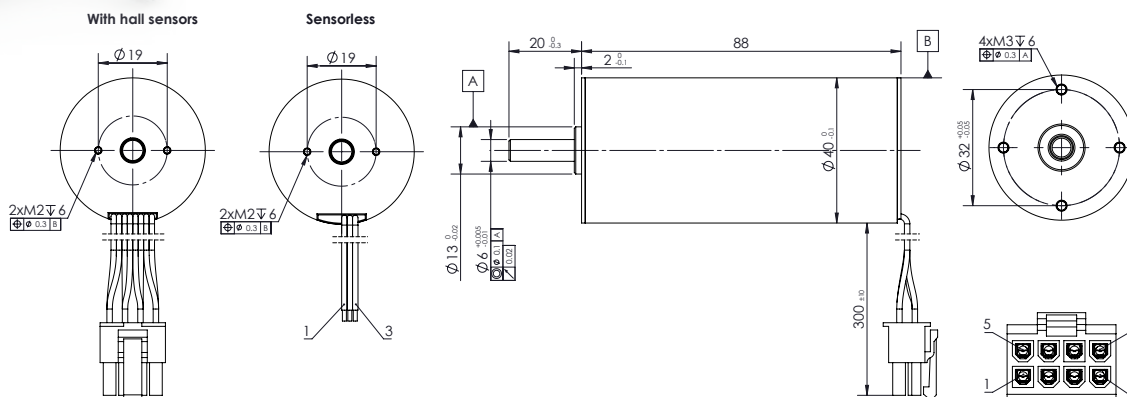

servotecnica
CORELESS
BRUSHLESS

V 3

Values	Unit	SVTN A 01 4088-24..	4088-36..	4088-48..
--------	------	------------------------	-----------	-----------

Motor Data					
1	Nominal voltage	V	24	36	48
2	No load speed	rpm	7921	8032	8081
3	No load current	mA	440	290	200
4	Nominal speed	rpm	7299	7379	7452
5	Nominal torque	mNm	200	200	200
6	Nominal current	A	7,39	4,99	3,74
7	Stall torque	mNm	2546	2460	2570
8	Stall current	A	88,9	58,1	45,7
9	Max. efficiency	%	86,4	86,4	87,2
Characteristics					
10	Terminal resistance*	Ω	0,27	0,62	1,05
11	Terminal inductance*	mH	0,18	0,38	0,78
12	Torque constant	mNm/A	28,8	42,6	56,5
13	Speed constant	rpm/V	332	224	169
14	Speed/torque gradient	rpm/mNm	3,1	3,3	3,1
15	Mechanical time constant	ms	1,8	1,9	1,8
16	Rotor inertia	gcm ²	54,1	54,1	54,1

Mechanical data		
17	Thermal resistance housing-ambient	3.0 K/W
18	Thermal resistance winding-housing	0.6 K/W
19	Thermal time constant winding	48 s
20	Thermal time constant motor	996 s
21	Ambient temperature	-30...+100°C
22	Max. permissible winding temperature	+150°C
23	Max. permissible speed	17500 rpm
24	Radial play	preloaded
25	Max. axial load (dynamic)	9 N
26	Max. force for press fits (static)	170 N
27	Max. radial load, 5mm from flange	80 N
Other specifications		
28	Number of poles	2
29	Number of phases	3
30	Weight	571 g

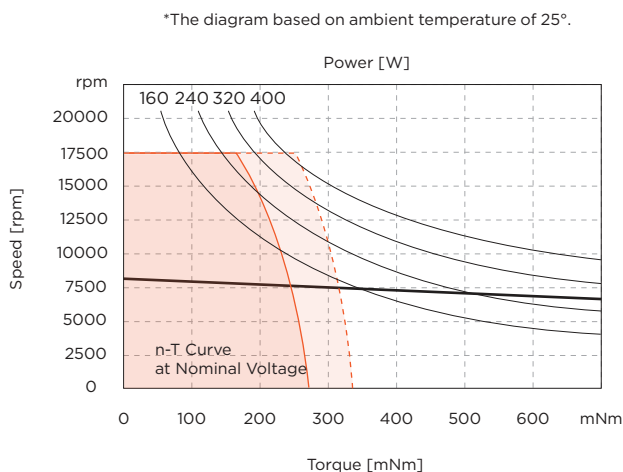

Continuous operating range
Continuous operating range with Reduced RtnZ 50%

Connection

Connection H (Sensor)			
Connection H	(Sensor)	PTFE	
Pin 1	Motor winding MB	AWG20	green
Pin 2	Vhall 3-18 VDC	AWG26	red
Pin 3	Hall sensor HA	AWG26	yellow
Pin 4	Hall sensor HC	AWG26	blue
Pin 5	Motor winding MA	AWG20	yellow
Pin 6	Motor winding MC	AWG20	blue
Pin 7	GND	AWG26	black
Pin 8	Hall sensor HB	AWG26	green
Connector			
Molex	39-01-2080		
Connection O (Sensorless)			
Connection O	(Sensorless)	PTFE	
Pin 1	Motor winding MA	AWG20	yellow
Pin 2	Motor winding MB	AWG20	green
Pin 3	Motor winding MC	AWG20	blue

Drive combinations

Hall sensors	Encoder
SVTE-A-E40	SVTE-A-E45
SVTE-A-E50	SVTE-A-E55

Encoder combinations

EN 24
EN 24L

Gearbox combinations

SVTG B 42

ATOM HS Series

SVTN A 02

Coreless BLDC motors
2 Pole High-speed Brushless DC Motors

ATOM HS Series

SVTN A 02

Coreless BLDC motors
2 Pole High-speed Brushless DC Motors



Cost effective



Low noise



High speed



Typically employed in the medical field for surgical tools, these motors merge the SVTN A Series characteristics to a optimized project for high-speed functions.

Thanks to a precise balancing of the rotor and the use of special bearings, maximum stability and low noise are guaranteed.

Benefits

High-speed

Long lifespan

Cost-effective

Low inertia

High efficiency

Low noise

High reliability

Product code

SVTN A 02 ○○◇◇ - □□ - 〡 - 〡☆☆

A Series

02 Brushless DC Motors

○ Diameter

◇ Length

□ Nominal Voltage

〡 Shaft
Single shaft - standard [S]; Double shaft [D]

〡 Sensor
Sensorless [0]; Hall sensor - standard [H]*

☆☆ Customizations

* Not available for SVTN A 02 2053 and SVTN A 02 2057

Features

Winding	3 phase
Operating temperature	-30° +100° C
Connectors	JST PHR-8 1636; 1644; 1656; 2040
Magnets	Neodymium
Design technology	Coreless winding system
Estimated operating lifetime	Lifetime depends on motor working conditions. It can reach 20.000 hours under optimal conditions.

Feedback

Hall Sensor (standard)

Customizations

Flange	Shape
Shaft	Length/Diameter/D-Cut
Leadwire	PVC/Silicon/Teflon/UL No/Dimension/length
Connector	JST



ATOM HS Series SVTN A 02 1636

50 Watt

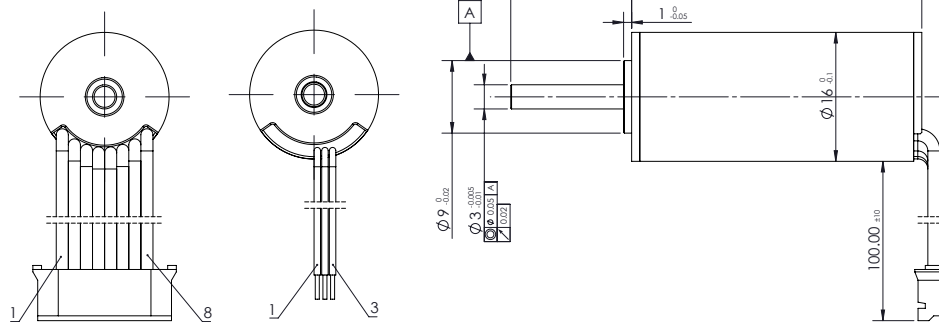

V 3

Values	Unit	SVTN A 02	1636-24..	1636-30..	1636-36..
Motor Data					
1	Nominal voltage	V	24	30	36
2	No load speed	rpm	40273	40225	40760
3	No load current	mA	90	77	72
4	Nominal speed	rpm	37067	36958	37406
5	Nominal torque	mNm	5	5	5
6	Nominal current	A	0,98	0,79	0,67
7	Stall torque	mNm	62,8	61,6	60,8
8	Stall current	A	11,2	8,8	7,3
9	Max. efficiency	%	82,9	82,2	81,2
Characteristics					
10	Terminal resistance*	Ω	2,14	3,41	4,9
11	Terminal inductance*	mH	0,11	0,17	0,24
12	Torque constant	mNm/A	5,65	7,06	8,35
13	Speed constant	rpm/V	1692	1353	1143
14	Speed/torque gradient	rpm/mNm	641	653	671
15	Mechanical time constant	ms	3,7	3,8	3,9
16	Rotor inertia	gcm ²	0,55	0,55	0,55
Mechanical data					
17	Thermal resistance housing-ambient	K/W	18,6		
18	Thermal resistance winding-housing	K/W	3,44		
19	Thermal time constant winding	s	6		
20	Thermal time constant motor	s	298		
21	Ambient temperature	°C	-30...+100		
22	Max. permissible winding temperature	°C	+150		
23	Max. permissible speed	rpm	80000		
24	Radial play		preloaded		
25	Max. axial load (dynamic)	N	2,5		
26	Max. force for press fits (static)	N	44		
27	Max. radial load, 5mm from flange	N	11		
Other specifications					
28	Number of poles		2		
29	Number of phases		3		
30	Weight	g	32		

*The diagram based on ambient temperature of 25°.

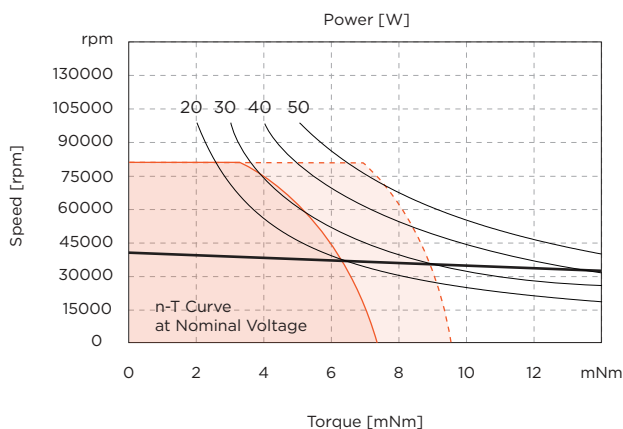

Continuous operating range
Continuous operating range with Reduced RtnZ 50%

Connection

Connection H (Sensor)	PVC
Pin 1	Vhall 3-18 VDC
Pin 2	Hall sensor HA
Pin 3	Hall sensor HB
Pin 4	Hall sensor HC
Pin 5	GND
Pin 6	Motor winding MA
Pin 7	Motor winding MB
Pin 8	Motor winding MC
Connector	JST PHR-8
Connection O (Sensorless)	
Pin 1	Motor winding MA
Pin 2	Motor winding MB
Pin 3	Motor winding MC

Drive combinations

Hall sensors
SVTE-A-E45
SVTE-A-E55



ATOM HS Series
SVTN A 02 1644

55 Watt

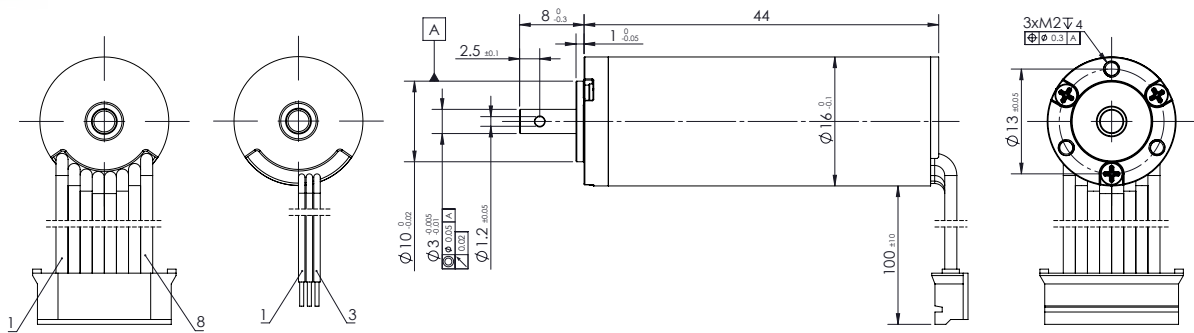

V 3

Values	Unit	SVTN A 02	1644-24..	1644-30..	1644-36..
Motor Data					
1	Nominal voltage	V	24	30	36
2	No load speed	rpm	30580	30900	30160
3	No load current	mA	95	80	76
4	Nominal speed	rpm	28134	28403	27632
5	Nominal torque	mNm	7,5	7,5	7,5
6	Nominal current	A	1,1	0,9	0,74
7	Stall torque	mNm	93,8	92,8	89,5
8	Stall current	A	12,7	10,2	8
9	Max. efficiency	%	83,4	83	81,5
Characteristics					
10	Terminal resistance*	Ω	1,89	2,95	4,5
11	Terminal inductance*	mH	0,12	0,19	0,28
12	Torque constant	mNm/A	7,44	9,2	11,3
13	Speed constant	rpm/V	1284	1038	846
14	Speed/torque gradient	rpm/mNm	326	333	337
15	Mechanical time constant	ms	2,8	2,9	2,9
16	Rotor inertia	gcm ²	0,82	0,82	0,82
Mechanical data					
17	Thermal resistance housing-ambient	K/W	16,2		
18	Thermal resistance winding-housing	K/W	3,5		
19	Thermal time constant winding	s	4		
20	Thermal time constant motor	s	339		
21	Ambient temperature	°C	-30...+100		
22	Max. permissible winding temperature	°C	+150		
23	Max. permissible speed	rpm	80000		
24	Radial play		preloaded		
25	Max. axial load (dynamic)	N	2,5		
26	Max. force for press fits (static)	N	44		
27	Max. radial load, 5mm from flange	N	11		
Other specifications					
28	Number of poles		2		
29	Number of phases		3		
30	Weight	g	43g		

*The diagram based on ambient temperature of 25°.

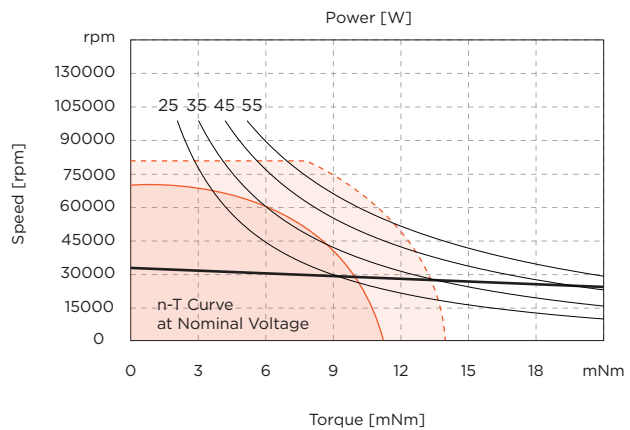

Continuous operating range
Continuous operating range with Reduced RthZ 50%

Connection

Connection H (Sensor)	PVC
Pin 1	Vhall 3-18 VDC
Pin 2	Hall sensor HA
Pin 3	Hall sensor HB
Pin 4	Hall sensor HC
Pin 5	GND
Pin 6	Motor winding MA
Pin 7	Motor winding MB
Pin 8	Motor winding MC
Connector	JST PHR-8
Connection O (Sensorless)	
Pin 1	Motor winding MA
Pin 2	Motor winding MB
Pin 3	Motor winding MC

Drive combinations

Hall sensors
SVTE-A-E45
SVTE-A-E55



ATOM HS Series SVTN A 02 1656

75 Watt

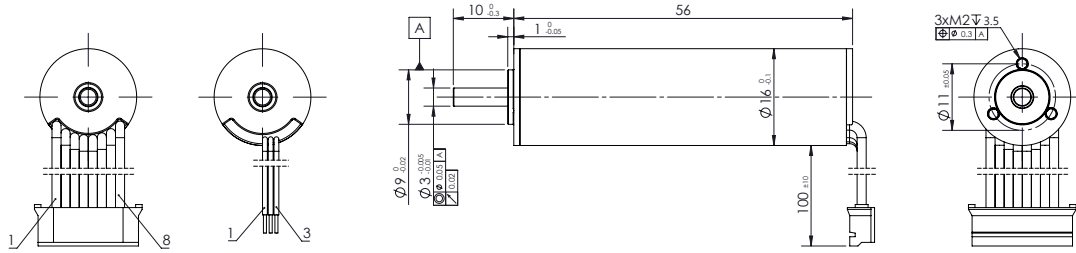

V 3

Values	Unit	SVTN A 02 1656-24..	1656-30..	1656-36..	
Motor Data					
1	Nominal voltage	V	24	30	36
2	No load speed	rpm	41670	40775	41311
3	No load current	mA	103	89	79
4	Nominal speed	rpm	39232	38438	38898
5	Nominal torque	mNm	6	6	6
6	Nominal current	A	1,2	0,95	0,8
7	Stall torque	mNm	103	105	103
8	Stall current	A	18,9	15,1	12,5
9	Max. efficiency	%	85,8	85,2	84,7
Characteristics					
10	Terminal resistance*	Ω	1,27	1,99	2,88
11	Terminal inductance*	mH	0,09	0,14	0,2
12	Torque constant	mNm/A	5,47	6,98	8,27
13	Speed constant	rpm/V	1746	1367	1155
14	Speed/torque gradient	rpm/mNm	406	390	402
15	Mechanical time constant	ms	2,6	2,5	2,6
16	Rotor inertia	gcm ²	0,61	0,61	0,61
Mechanical data					
17	Thermal resistance housing-ambient	K/W	16,2		
18	Thermal resistance winding-housing	K/W	1,9		
19	Thermal time constant winding	s	5		
20	Thermal time constant motor	s	397		
21	Ambient temperature	°C	-30...+100		
22	Max. permissible winding temperature	°C	+150		
23	Max. permissible speed	rpm	80000		
24	Radial play		preloaded		
25	Max. axial load (dynamic)	N	2,5		
26	Max. force for press fits (static)	N	44		
27	Max. radial load, 5mm from flange	N	11		
Other specifications					
28	Number of poles		2		
29	Number of phases		3		
30	Weight	g	50		

*The diagram based on ambient temperature of 25°.

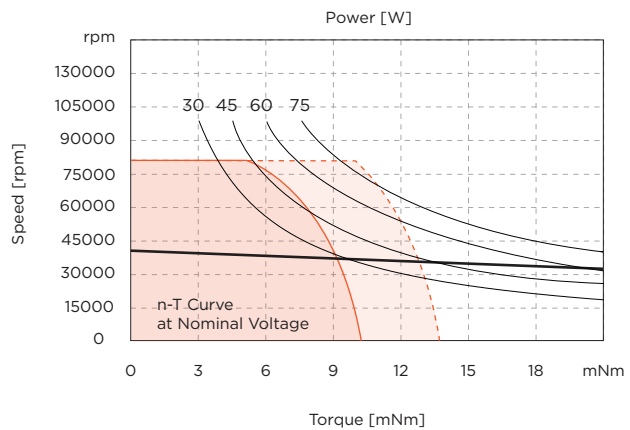

Continuous operating range
Continuous operating range with Reduced RTN2 50%

Connection

Connection H (Sensor)	PVC
Pin 1	Vhall 3-18 VDC
Pin 2	Hall sensor HA
Pin 3	Hall sensor HB
Pin 4	Hall sensor HC
Pin 5	GND
Pin 6	Motor winding MA
Pin 7	Motor winding MB
Pin 8	Motor winding MC
Connector	JST PHR-8
Connection O (Sensorless)	
Pin 1	Motor winding MA
Pin 2	Motor winding MB
Pin 3	Motor winding MC

Drive combinations

Hall sensors
SVTE-A-E45
SVTE-A-E55



ATOM HS Series
SVTN A 02 2040

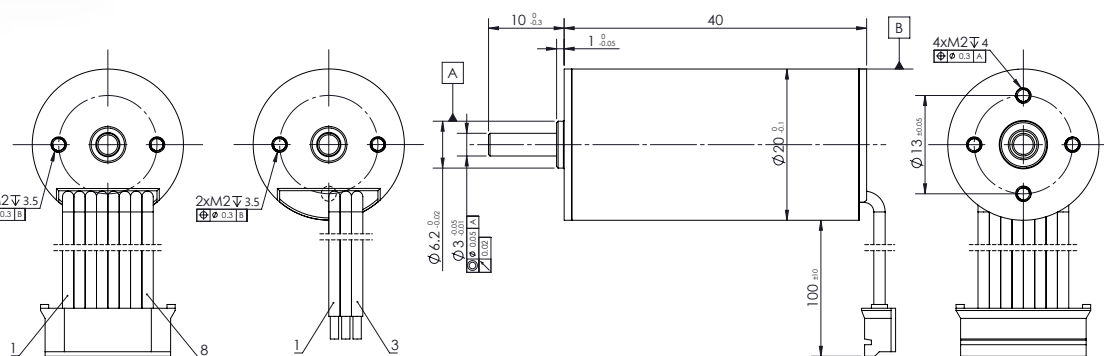

V 3

Values	Unit	SVTN A 02	2040-24..	2040-30..	2040-36..
--------	------	-----------	-----------	-----------	-----------

Motor Data					
1	Nominal voltage	V	24	30	36
2	No load speed	rpm	41392	40700	40020
3	No load current	mA	69	60	55
4	Nominal speed	rpm	37500	36777	36049
5	Nominal torque	mNm	6,3	6,3	6,3
6	Nominal current	A	1,21	0,96	0,79
7	Stall torque	mNm	67	65,4	63,5
8	Stall current	A	12,2	9,4	7,5
9	Max. efficiency	%	85,5	84,7	83,6
Characteristics					
10	Terminal resistance*	Ω	1,96	3,19	4,8
11	Terminal inductance*	mH	0,21	0,47	0,47
12	Torque constant	mNm/A	5,51	6,99	8,53
13	Speed constant	rpm/V	1734	1365	1120
14	Speed/torque gradient	rpm/mNm	618	623	630
15	Mechanical time constant	ms	4,5	4,5	4,6
16	Rotor inertia	gcm ²	0,69	0,69	0,69

Mechanical data		
17	Thermal resistance housing-ambient	18.7 K/W
18	Thermal resistance winding-housing	1.9 K/W
19	Thermal time constant winding	5 s
20	Thermal time constant motor	397 s
21	Ambient temperature	-30...+100°C
22	Max. permissible winding temperature	+150°C
23	Max. permissible speed	80000 rpm
24	Radial play	preloaded
25	Max. axial load (dynamic)	2.5 N
26	Max. force for press fits (static)	44 N
27	Max. radial load, 5mm from flange	11 N

Other specifications		
28	Number of poles	2
29	Number of phases	3
30	Weight	53 g

*The diagram based on ambient temperature of 25°.

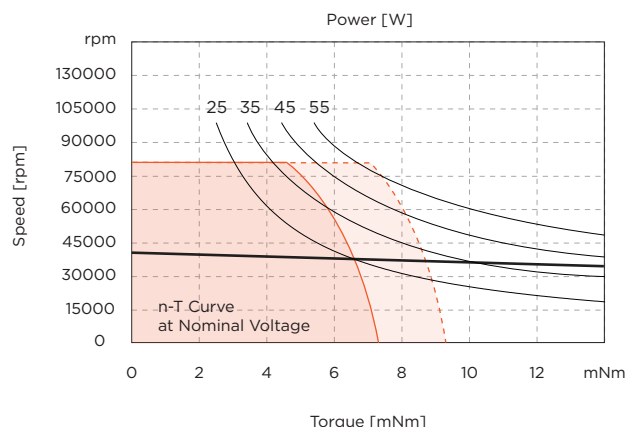

Continuous operating range
Continuous operating range with Reduced RtnZ 50%

Connection

Connection	(Sensor)	PVC
Pin 1	Vhall 3-18 VDC	AWG26 black
Pin 2	Hall sensor HA	AWG26 black
Pin 3	Hall sensor HB	AWG26 black
Pin 4	Hall sensor HC	AWG26 black
Pin 5	GND	AWG26 black
Pin 6	Motor winding MA	AWG26 black
Pin 7	Motor winding MB	AWG26 black
Pin 8	Motor winding MC	AWG26 black
Connector	PHR-8	
Connection	(Sensorless)	
Pin 1	Motor winding MA	AWG26 yellow
Pin 2	Motor winding MB	AWG26 green
Pin 3	Motor winding MC	AWG26 blue

Drive combinations

- Hall sensors**
SVTE-A-E45
SVTE-A-E55



ATOM HS Series SVTN A 02 2053

100 Watt

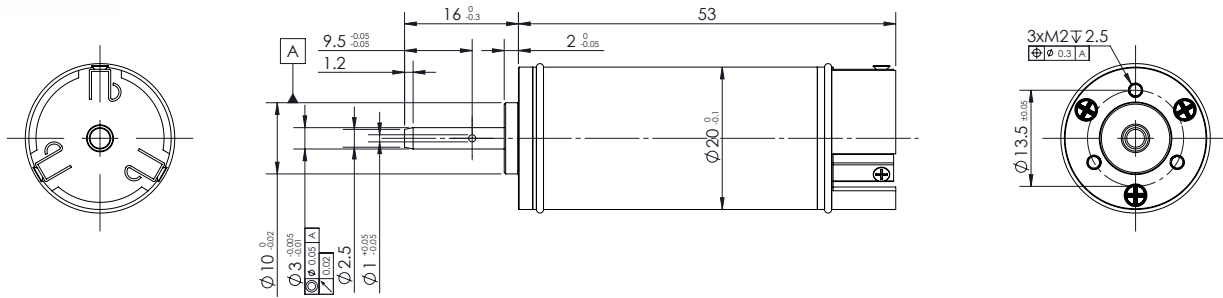
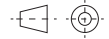

V 3

Values	Unit	SVTN A 02	2053-18..	2053-24..	2053-36..	2053-48..
Motor Data						
1	Nominal voltage	V	18	24	36	48
2	No load speed	rpm	50202	50832	51448	50700
3	No load current	mA	136	107	81	68
4	Nominal speed	rpm	45684	46379	46936	46188
5	Nominal torque	mNm	10	10	10	10
6	Nominal current	A	3,07	2,33	1,58	1,18
7	Stall torque	mNm	111	114	114	112
8	Stall current	A	32,7	25,5	17,2	12,6
9	Max. efficiency	%	87,5	87,5	86,8	85,8
Characteristics						
10	Terminal resistance*	Ω	0,55	0,94	2,09	3,82
11	Terminal inductance*	mH	0,06	0,1	0,23	0,38
12	Torque constant	mNm/A	3,41	4,49	6,65	8,99
13	Speed constant	rpm/V	2801	2127	1436	1062
14	Speed/torque gradient	rpm/mNm	452	445	451	451
15	Mechanical time constant	ms	3,9	3,9	3,9	3,9
16	Rotor inertia	gcm ²	0,83	0,83	0,83	0,83
Mechanical data						
17	Thermal resistance housing-ambient	K/W	11,8			
18	Thermal resistance winding-housing	K/W	0,8			
19	Thermal time constant winding	s	2			
20	Thermal time constant motor	s	386			
21	Ambient temperature	°C	-30...+100			
22	Max. permissible winding temperature	°C	+150			
23	Max. permissible speed	rpm	80000			
24	Radial play		preloaded			
25	Max. axial load (dynamic)	N	2,5			
26	Max. force for press fits (static)	N	44			
27	Max. radial load, 5mm from flange	N	11			
Other specifications						
28	Number of poles		2			
29	Number of phases		3			
30	Weight	g	63			

*The diagram based on ambient temperature of 25°.

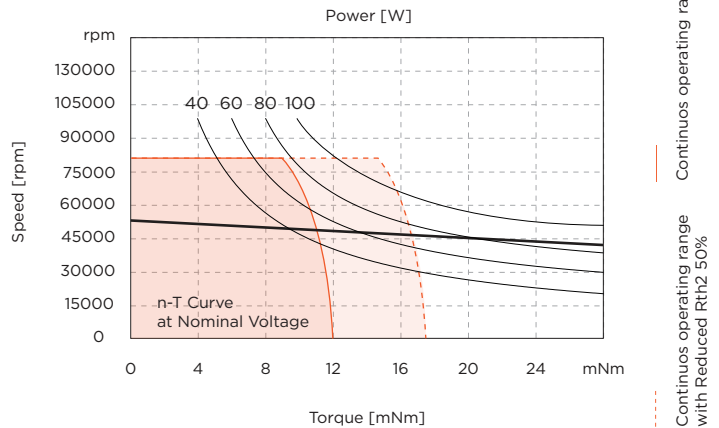

Connection

Screw terminals



ATOM HS Series
SVTN A 02 2057

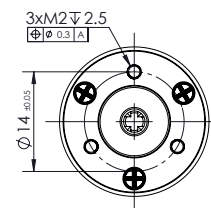
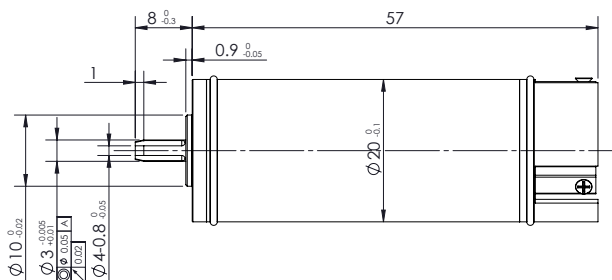
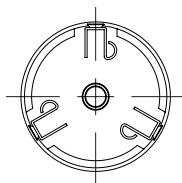

V 3

Values	Unit	SVTN A 02	2057-18..	2057-24..	2057-36..	2057-48..
Motor Data						
1	Nominal voltage	V	18	24	36	48
2	No load speed	rpm	50202	50832	51286	50700
3	No load current	mA	210	158	113	94
4	Nominal speed	rpm	46263	46714	47328	46436
5	Nominal torque	mNm	15	15	15	15
6	Nominal current	A	4,61	3,5	2,36	1,76
7	Stall torque	mNm	191	185	194	178
8	Stall current	A	56,3	41,4	29,2	19,9
9	Max. efficiency	%	88,2	88	87,9	86,7
Characteristics						
10	Terminal resistance*	Ω	0,32	0,58	1,23	2,41
11	Terminal inductance*	mH	0,04	0,06	0,14	0,25
12	Torque constant	mNm/A	3,41	4,49	6,68	9
13	Speed constant	rpm/V	2799	2126	1430	1061
14	Speed/torque gradient	rpm/mNm	263	275	264	284
15	Mechanical time constant	ms	2,5	2,6	2,5	2,7
16	Rotor inertia	gcm ²	0,91	0,91	0,91	0,91
Mechanical data						
17	Thermal resistance housing-ambient	K/W	7,6			
18	Thermal resistance winding-housing	K/W	1,6			
19	Thermal time constant winding	s	5			
20	Thermal time constant motor	s	410			
21	Ambient temperature	°C	-30...+100			
22	Max. permissible winding temperature	°C	+150			
23	Max. permissible speed	rpm	80000			
24	Radial play		preloaded			
25	Max. axial load (dynamic)	N	2,5			
26	Max. force for press fits (static)	N	44			
27	Max. radial load, 5mm from flange	N	11			
Other specifications						
28	Number of poles		2			
29	Number of phases		3			
30	Weight	g	69			

*The diagram based on ambient temperature of 25°.

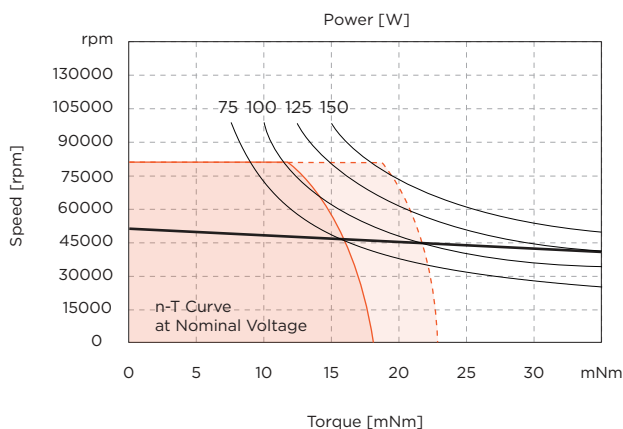

Continuous operating range
Continuous operating range with Reduced RTN2 50%

Connection

Screw terminals

ATOM SC Series

SVTN A 03

Coreless BLDC motors

2 Pole Brushless DC Motors with Integrated Electronics

ATOM SC Series

SVTN A 03

Coreless BLDC motors

2 Pole Brushless DC Motors with Integrated Electronics



Cost effective



Easy to use



Long service life



The benefits of this build technology join the simplicity of use of a brushed DC motor with the longevity of a brushless motor, maintaining cost-effectiveness and ease of integration.

The lack of cogging is typical of the coreless motors and guarantees a reduce ripple torque, a linear correlation between torque, speed and low inertia.

The miniaturization of the electronics allows to maintain the diameter of the motor unvaried with a slight increase in length.

Benefits

Long lifetime

High efficiency

Low noise

High reliability

No cogging

Low inertia

Cost-effective

Product code

SVTN A 03 ○○◇◇ - □□ - 〡 - 〡☆☆

A Series

03 Brushless DC Motors

○ Diameter

◇ Length

□ Voltage

〡 Shaft
Single shaft [S]; Double shaft [D]

〡 Direction of rotation
CW [0]; CCW [1]; Third wire for direction control [2]

☆☆ Customizations

Features

Winding	3 phase (2-wires DC regulated)
Operating temperature	-30° +100° C
Connectors	Flying leads or JST* or MOLEX*
Magnets	Neodymium
Construction technology	Coreless winding system
Estimated operating lifetime	Lifetime depends on motor working conditions. It can reach 20.000 work hours under optimal conditions (almost 100 hours under extreme conditions).

Customizations

Flange	Shape
Shaft	Length/Diameter/D-Cut
Leadwire	PVC/Silicon/Teflon/UL No/Dimension/length
Connector	JST/MOLEX

*Optional



ATOM SC Series SVTN A 03 1228

1.5 Watt

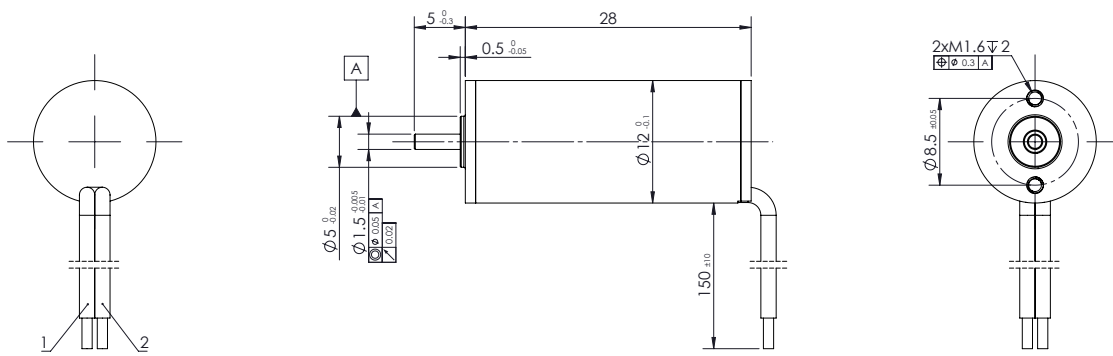

V 3

Values	Unit	SVTN A 03 1228-06..
Motor Data		
1	Nominal voltage	V
2	No load speed	rpm
3	No load current	mA
4	Nominal speed	rpm
5	Nominal torque	mNm
6	Nominal current	A
7	Stall torque	mNm
8	Stall current	A
9	Max. efficiency	%
Characteristics		
10	Supply Voltage +Vcc	V
11	Direction of rotation	CCW viewed from shaft end
12	Torque constant	mNm/A
13	Speed constant	rpm/V
14	Speed/torque gradient	rpm/mNm
15	Mechanical time constant	ms
16	Rotor inertia	gcm ²
Mechanical data		
17	Thermal resistance housing-ambient	38,3 K/W
18	Thermal resistance winding-housing	9,6 K/W
19	Thermal time constant winding	5 s
20	Thermal time constant motor	196 s
21	Ambient temperature	-30...+100°C
22	Max. permissible winding temperature	+125°C
23	Max. permissible speed	50000 rpm
24	Radial play	preloaded
25	Max. axial load (dynamic)	0,3
26	Max. force for press fits (static)	11N
27	(static, shaft supported)	200 N
28	Max. radial load, 5mm from flange	4,3 N
Other specifications		
29	Number of poles	2
30	Number of phases	3
31	Weight	12,2 g

Connection

Connection	PTFE
Pin 1 +VCC	AWG24 red
Pin 2 GND	AWG24 black

Optional:

Pin 3 FR*	AWG28 yellow
-----------	--------------

*Reverse direction when connected to GND

Gearbox combinations

SVTG A 10
SVTG A 12

Caution
Incorrect lead connection will damage the controller!



ATOM SC Series
SVTN A 03 1638

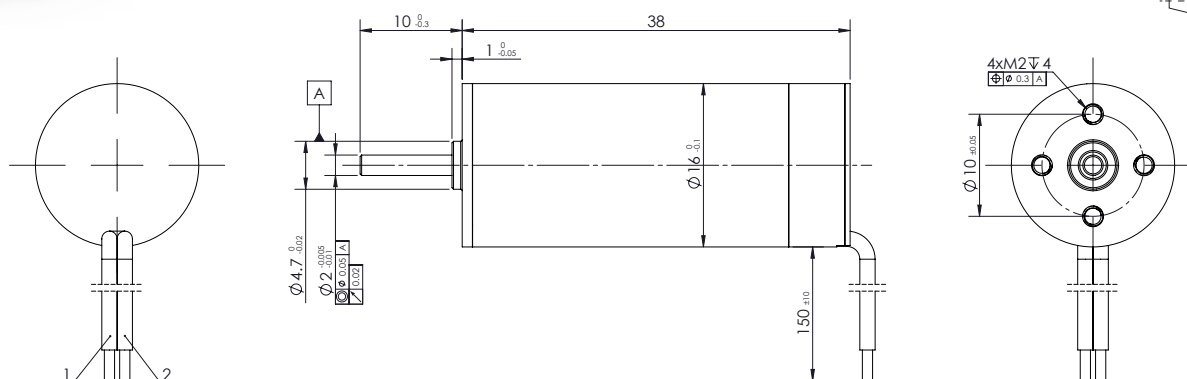

V 3

Values	Unit	SVTN A 03 1638-06..	1638-12..	
Motor Data				
1	Nominal voltage	V	6	12
2	No load speed	rpm	8832	17664
3	No load current	mA	110	100
4	Nominal speed	rpm	6102	14491
5	Nominal torque	mNm	1,5	2
6	Nominal current	A	0,37	0,43
7	Stall torque	mNm	4,85	11,1
8	Stall current	A	0,96	1,91
9	Max. efficiency	%	43,7	59,5
Characteristics				
10	Supply Voltage +Vcc	V	4.5..7	8..13
11	Direction of rotation		CCW viewed from shaft end	
12	Torque constant	mNm/A	5,74	6,11
13	Speed constant	rpm/V	1664	1562
14	Speed/torque gradient	rpm/mNm	1820	1604
15	Mechanical time constant	ms	8,2	7,2
16	Rotor inertia	gcm ²	0,4	0,4
Mechanical data				
17	Thermal resistance housing-ambient		20.2 K/W	
18	Thermal resistance winding-housing		8.7 K/W	
19	Thermal time constant winding		7 s	
20	Thermal time constant motor		238 s	
21	Ambient temperature		-30...+100°C	
22	Max. permissible winding temperature		+150°C	
23	Max. permissible speed		35000 rpm	
24	Radial play		preloaded	
25	Max. axial load (dynamic)		1.3 N	
26	Max. force for press fits (static)		15 N	
27	(static, shaft supported)		350 N	
28	Max. radial load, 5mm from flange		5 N	
Other specifications				
29	Number of poles		2	
30	Number of phases		3	
31	Weight		27 g	

Connection

Connection		PTFE
Pin 1	+VCC	AWG24 red
Pin 2	GND	AWG24 black

Optional:

Pin 3	FR*	AWG28 yellow
-------	-----	--------------

*Reverse direction when connected to GND

Caution
Incorrect lead connection will damage the controller!

Gearbox combinations

SVTG A 16



ATOM SC Series SVTN A 03 2238

9 Watt

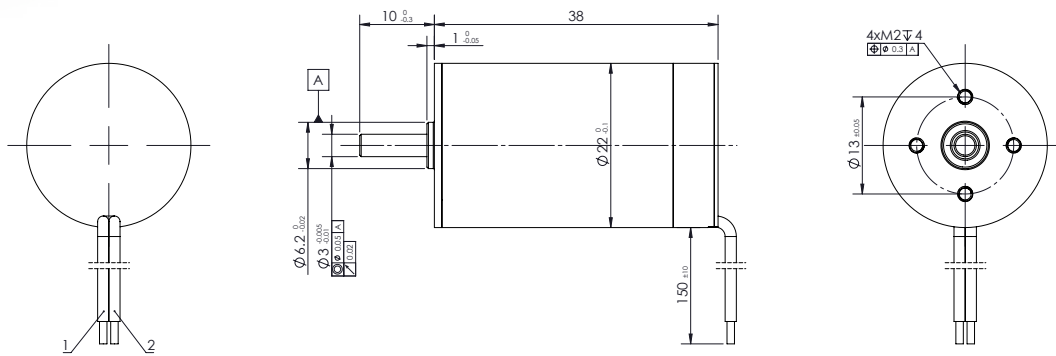
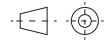

V 3

Values	Unit	SVTN A 03 2238-12..	2238-18..	2238-24..	
Motor Data					
1	Nominal voltage	V	12	18	24
2	No load speed	rpm	17445	17830	17721
3	No load current	mA	220	150	110
4	Nominal speed	rpm	14292	14700	14260
5	Nominal torque	mNm	6	6	6
6	Nominal current	A	1,13	0,75	0,57
7	Stall torque	mNm	44,8	45,3	40,7
8	Stall current	A	7,44	4,96	3,39
9	Max. efficiency	%	70,2	70,3	67,7
Characteristics					
10	Supply Voltage +Vcc	V	10..28	10..28	10..28
11	Direction of rotation		CCW viewed from shaft end		
12	Torque constant	mNm/A	6,15	9,32	12,3
13	Speed constant	rpm/V	1553	1024	777
14	Speed/torque gradient	rpm/mNm	407	399	447
15	Mechanical time constant	ms	6,4	6,2	7
16	Rotor inertia	gcm ²	1,5	1,5	1,5
Mechanical data					
17	Thermal resistance housing-ambient		15.2 K/W		
18	Thermal resistance winding-housing		6.0 K/W		
19	Thermal time constant winding		11 s		
20	Thermal time constant motor		383 s		
21	Ambient temperature		-30...+100°C		
22	Max. permissible winding temperature		+150°C		
23	Max. permissible speed		35000 rpm		
24	Radial play		preloaded		
25	Max. axial load (dynamic)		3.5 N		
26	Max. force for press fits (static)		44 N		
27	Max. radial load, 5mm from flange		15 N		
Other specifications					
28	Number of poles		2		
29	Number of phases		3		
30	Weight		63 g		

Connection

Connection		PTFE
Pin 1	+VCC	AWG24 red
Pin 2	GND	AWG24 black

Optional:

Pin 3	FR*	AWG28 yellow
-------	-----	--------------

*Reverse direction when connected to GND

Gearbox combinations

SVTG B 22*
SVTG B 24*

Caution
Incorrect lead connection will damage the controller!

*On request. Contact factory.



ATOM SC Series
SVTN A 03 2246

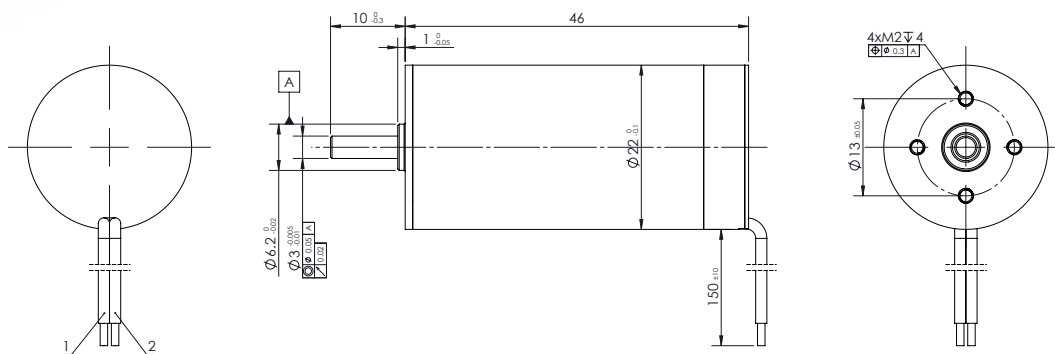

V 3

Values	Unit	SVTN A 03 2246-12..	2246-24..
Motor Data			
1	Nominal voltage	V	12 24
2	No load speed	rpm	11570 15627
3	No load current	mA	170 140
4	Nominal speed	rpm	10085 12771
5	Nominal torque	mNm	8 12
6	Nominal current	A	1,01 1,01
7	Stall torque	mNm	60,4 82,8
8	Stall current	A	6,7 6,28
9	Max. efficiency	%	70,5 71,8
Characteristics			
10	Supply Voltage +Vcc	V	10..28 10..28
11	Direction of rotation		CCW viewed from shaft end
12	Torque constant	mNm/A	9,2 13,4
13	Speed constant	rpm/V	1038 712
14	Speed/torque gradient	rpm/mNm	202 203
15	Mechanical time constant	ms	4,8 4,8
16	Rotor inertia	gcm ²	2,3 2,3
Mechanical data			
17	Thermal resistance housing-ambient		12,7 K/W
18	Thermal resistance winding-housing		5,0 K/W
19	Thermal time constant winding		12 s
20	Thermal time constant motor		420 s
21	Ambient temperature		-30...+100°C
22	Max. permissible winding temperature		+150°C
23	Max. permissible speed		35000 rpm
24	Radial play		preloaded
25	Max. axial load (dynamic)		3,5 N
26	Max. force for press fits (static)		44 N
27	Max. radial load, 5mm from flange		15 N
Other specifications			
28	Number of poles		2
29	Number of phases		3
30	Weight		79 g

Connection

Connection		PTFE
Pin 1	+VCC	AWG24 red
Pin 2	GND	AWG24 black

Optional:

Pin 3	FR*	AWG28 yellow
-------	-----	--------------

*Reverse direction when connected to GND

Caution
Incorrect lead connection will damage the controller!

Gearbox combinations

- SVTG B 22*
- SVTG B 24*

*On request. Contact factory.



ATOM SC Series SVTN A 03 2452

8 Watt

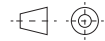
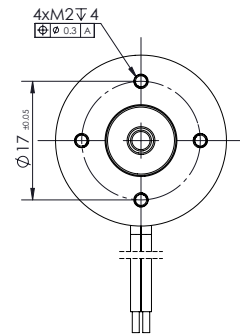
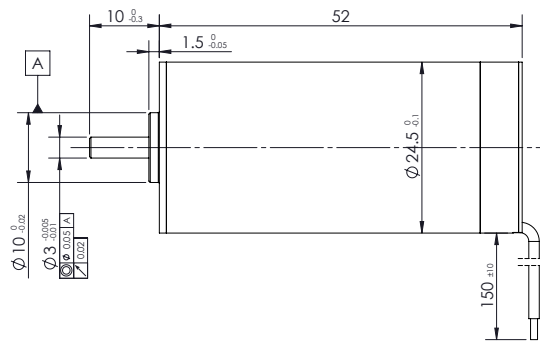
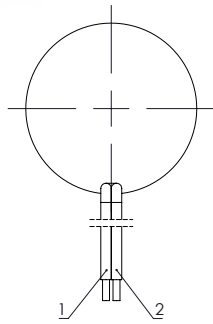

V 3

Values	Unit	SVTN A 03 2452-12..	2452-24..	
Motor Data				
1	Nominal voltage	V	12	24
2	No load speed	rpm	6904	6980
3	No load current	mA	103	70
4	Nominal speed	rpm	5087	5089
5	Nominal torque	mNm	14	14
6	Nominal current	A	0,98	0,51
7	Stall torque	mNm	87	85,2
8	Stall current	A	5,58	2,73
9	Max. efficiency	%	71,7	67,9
Characteristics				
10	Supply Voltage +Vcc	V	10..28	10..28
11	Direction of rotation		CCW viewed from shaft end	
12	Torque constant	mNm/A	15,9	32
13	Speed constant	rpm/V	601	298
14	Speed/torque gradient	rpm/mNm	81,3	81,9
15	Mechanical time constant	ms	3,6	3,6
16	Rotor inertia	gcm ²	4,2	4,2
Mechanical data				
17	Thermal resistance housing-ambient	K/W	11,6	
18	Thermal resistance winding-housing	K/W	5,6	
19	Thermal time constant winding	s	30	
20	Thermal time constant motor	s	557	
21	Ambient temperature	°C	-30...+100°C	
22	Max. permissible winding temperature	°C	+150°C	
23	Max. permissible speed	rpm	30000 rpm	
24	Radial play		preloaded	
25	Max. axial load (dynamic)	N	3,5 N	
26	Max. force for press fits (static)	N	44 N	
27	Max. radial load, 5mm from flange	N	15 N	
Other specifications				
28	Number of poles		2	
29	Number of phases		3	
30	Weight		112 g	

Connection

Connection		PTFE
Pin 1	+VCC	AWG24 red
Pin 2	GND	AWG24 black

Optional:

Pin 3	FR*	AWG28 yellow
-------	-----	--------------

*Reverse direction when connected to GND

Gearbox combinations

SVTG B 24*
SVTG B 28*

Caution
Incorrect lead connection will damage the controller!

*On request. Contact factory.



ATOM SC Series
SVTN A 03 2459

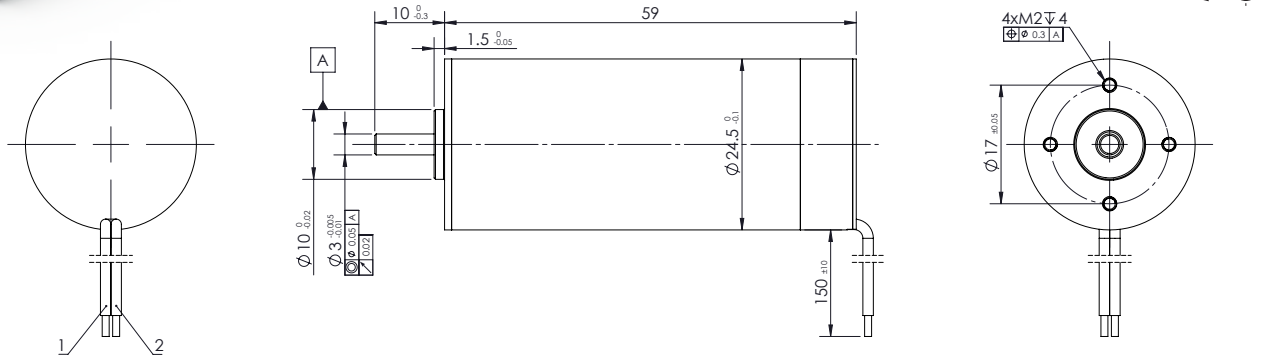

V 3

Values	Unit	SVTN A 03 2459-12..	2459-24..	
Motor Data				
1	Nominal voltage	V	12	24
2	No load speed	rpm	7699	7655
3	No load current	mA	114	73
4	Nominal speed	rpm	6958	6597
5	Nominal torque	mNm	14	20
6	Nominal current	A	1,07	0,75
7	Stall torque	mNm	145	145
8	Stall current	A	10	4,98
9	Max. efficiency	%	79,8	77,2
Characteristics				
10	Supply Voltage +Vcc	V	10..28	10..28
11	Direction of rotation		CCW viewed from shaft end	
12	Torque constant	mNm/A	14,7	29,5
13	Speed constant	rpm/V	649	324
14	Speed/torque gradient	rpm/mNm	52,9	52,9
15	Mechanical time constant	ms	3,3	3,3
16	Rotor inertia	gcm ²	5,9	5,9
Mechanical data				
17	Thermal resistance housing-ambient		10.2 K/W	
18	Thermal resistance winding-housing		6.4 K/W	
19	Thermal time constant winding		36 s	
20	Thermal time constant motor		555 s	
21	Ambient temperature		-30...+100°C	
22	Max. permissible winding temperature		+150°C	
23	Max. permissible speed		30000 rpm	
24	Radial play		preloaded	
25	Max. axial load (dynamic)		3.5 N	
26	Max. force for press fits (static)		44 N	
27	Max. radial load, 5mm from flange		15 N	
Other specifications				
28	Number of poles		2	
29	Number of phases		3	
30	Weight		130 g	

Connection

Connection		PTFE
Pin 1	+VCC	AWG24 red
Pin 2	GND	AWG24 black
Optional:		
Pin 3	FR*	AWG28 yellow

*Reverse direction when connected to GND

Gearbox combinations

- SVTG B 24
- SVTG B 28

Caution
Incorrect lead connection will damage the controller!



ATOM SC Series
SVTN A 03 2854

10 Watt

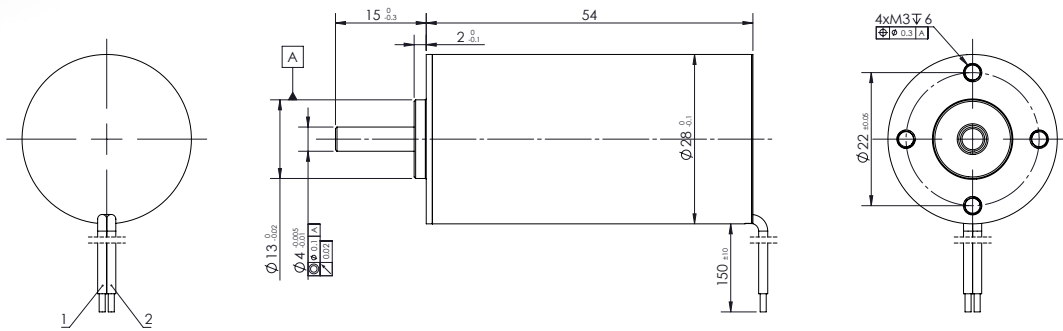

V 3

Values	Unit	SVTN A 03 2854-12..	2854-24..	
Motor Data				
1	Nominal voltage	V	12	24
2	No load speed	rpm	6878	6700
3	No load current	mA	121	76
4	Nominal speed	rpm	5674	5157
5	Nominal torque	mNm	15	18
6	Nominal current	A	1,04	0,62
7	Stall torque	mNm	85,7	78,1
8	Stall current	A	5,38	2,43
9	Max. efficiency	%	72,3	67,8
Characteristics				
10	Supply Voltage +Vcc	V	10..28	10..28
11	Direction of rotation		CCW viewed from shaft end	
12	Torque constant	mNm/A	16,3	33,1
13	Speed constant	rpm/V	586	288
14	Speed/torque gradient	rpm/mNm	80,3	85,7
15	Mechanical time constant	ms	4,4	4,7
16	Rotor inertia	gcm ²	5,2	5,2
Mechanical data				
17	Thermal resistance housing-ambient		9.6 K/W	
18	Thermal resistance winding-housing		6.3 K/W	
19	Thermal time constant winding		37 s	
20	Thermal time constant motor		584 s	
21	Ambient temperature		-30...+100°C	
22	Max. permissible winding temperature		+150°C	
23	Max. permissible speed		25000 rpm	
24	Radial play		preloaded	
25	Max. axial load (dynamic)		7.5 N	
26	Max. force for press fits (static)		100 N	
27	Max. radial load, 5mm from flange		25 N	
Other specifications				
28	Number of poles		2	
29	Number of phases		3	
30	Weight		153 g	

Connection

Connection		PTFE
Pin 1	+VCC	AWG20 red
Pin 2	GND	AWG20 black

Optional:

Pin 3	FR*	AWG28 yellow
-------	-----	--------------

*Reverse direction when connected to GND

Gearbox combination

SVTG B 28

Caution
Incorrect lead connection will damage the controller!



ATOM SC Series
SVTN A 03 2863

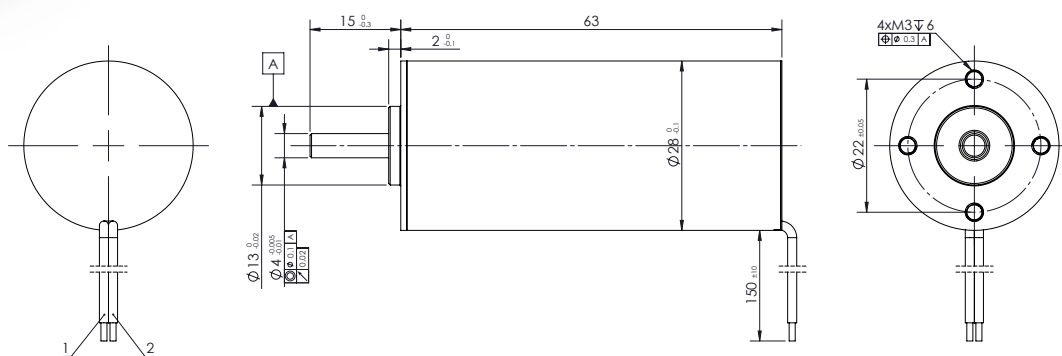

V 3

Values	Unit	SVTN A 03 2863-12..	2863-24..	
Motor Data				
1	Nominal voltage	V	12	24
2	No load speed	rpm	4168	4162
3	No load current	mA	70	60
4	Nominal speed	rpm	3264	3033
5	Nominal torque	mNm	25	25
6	Nominal current	A	0,99	0,53
7	Stall torque	mNm	115	92,1
8	Stall current	A	4,33	1,79
9	Max. efficiency	%	76,2	66,7
Characteristics				
10	Supply Voltage +Vcc	V	10..28	10..28
11	Direction of rotation		CCW viewed from shaft end	
12	Torque constant	mNm/A	27	53,2
13	Speed constant	rpm/V	353	179
14	Speed/torque gradient	rpm/mNm	36,2	45,2
15	Mechanical time constant	ms	3,2	4,0
16	Rotor inertia	gcm ²	8,5	8,5
Mechanical data				
17	Thermal resistance housing-ambient	K/W	7,1	
18	Thermal resistance winding-housing	K/W	5	
19	Thermal time constant winding	s	51	
20	Thermal time constant motor	s	552	
21	Ambient temperature	°C	-30...+100°C	
22	Max. permissible winding temperature	°C	+150°C	
23	Max. permissible speed	rpm	25000 rpm	
24	Radial play		preloaded	
25	Max. axial load (dynamic)	N	7,5 N	
26	Max. force for press fits (static)	N	100 N	
27	Max. radial load, 5mm from flange	N	25 N	
Other specifications				
28	Number of poles		2	
29	Number of phases		3	
30	Weight	g	188 g	

Connection

Connection		PTFE
Pin 1	+VCC	AWG20 red
Pin 2	GND	AWG20 black

Optional:

Pin 3	FR*	AWG28 yellow
-------	-----	--------------

*Reverse direction when connected to GND

Gearbox combinations

SVTG B 28

Caution
Incorrect lead connection will damage the controller!



ATOM SC Series
SVTN A 03 3270

26 Watt

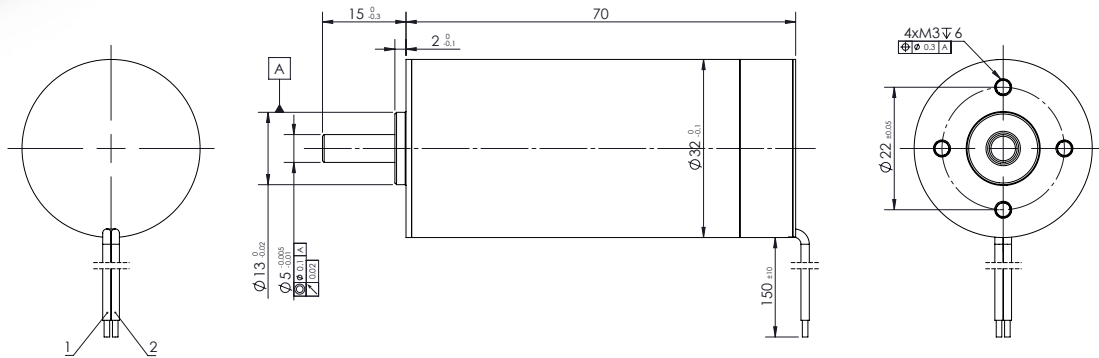

V 3

Values	Unit	SVTN A 03 3270-12..	3270-24..	
Motor Data				
1	Nominal voltage	V	12	24
2	No load speed	rpm	7200	7100
3	No load current	mA	194	110
4	Nominal speed	rpm	6623	6243
5	Nominal torque	mNm	25	40
6	Nominal current	A	1,78	1,36
7	Stall torque	mNm	312	331
8	Stall current	A	20	10,5
9	Max. efficiency	%	81,3	80,6
Characteristics				
10	Supply Voltage +Vcc	V	10..28	10..28
11	Direction of rotation		CCW viewed from shaft end	
12	Torque constant	mNm/A	15,8	31,9
13	Speed constant	rpm/V	606	299
14	Speed/torque gradient	rpm/mNm	23,1	21,4
15	Mechanical time constant	ms	3,7	3,5
16	Rotor inertia	gcm ²	15,5	15,5
Mechanical data				
17	Thermal resistance housing-ambient	K/W	5	
18	Thermal resistance winding-housing	K/W	4	
19	Thermal time constant winding	s	52	
20	Thermal time constant motor	s	540	
21	Ambient temperature	°C	-30...+100	
22	Max. permissible winding temperature	°C	+150	
23	Max. permissible speed	rpm	25000	
24	Radial play		preloaded	
25	Max. axial load (dynamic)	N	7,5	
26	Max. force for press fits (static)	N	100	
27	Max. radial load, 5mm from flange	N	25	
Other specifications				
28	Number of poles		2	
29	Number of phases		3	
30	Weight	g	255	

Connection

Connection		PTFE
Pin 1	+VCC	AWG20 red
Pin 2	GND	AWG20 black

Optional:

Pin 3	FR*	AWG28 yellow
-------	-----	--------------

*Reverse direction when connected to GND

Gearbox combinations

SVTG B 32
SVTG B 36

Caution
Incorrect lead connection will damage the controller!



ATOM SC Series
SVTN A 03 3673

17 Watt

servotecnica

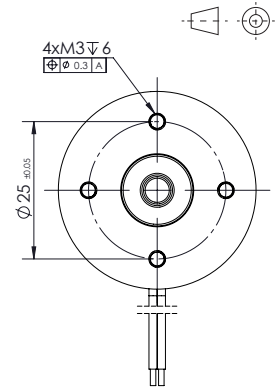
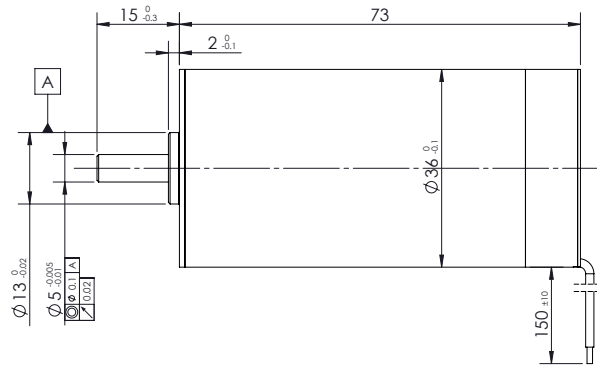
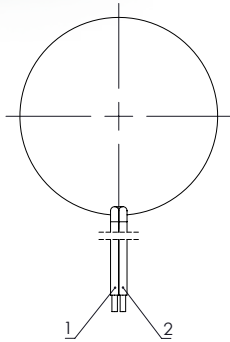

V 3

Values	Unit	SVTN A 03 3673-12..	3673-24..	
Motor Data				
1	Nominal voltage	V	12	24
2	No load speed	rpm	4070	4042
3	No load current	mA	148	84
4	Nominal speed	rpm	3229	3223
5	Nominal torque	mNm	50	50
6	Nominal current	A	1,95	0,98
7	Stall torque	mNm	242	247
8	Stall current	A	8,89	4,52
9	Max. efficiency	%	75,9	74,6
Characteristics				
10	Supply Voltage +Vcc	V	10..28	10..28
11	Direction of rotation		CCW viewed from shaft end	
12	Torque constant	mNm/A	27,7	55,7
13	Speed constant	rpm/V	345	172
14	Speed/torque gradient	rpm/mNm	16,8	16,4
15	Mechanical time constant	ms	3,4	3,3
16	Rotor inertia	gcm ²	19,5	19,5
Mechanical data				
17	Thermal resistance housing-ambient	K/W	4,9	
18	Thermal resistance winding-housing	K/W	1,6	
19	Thermal time constant winding	s	45	
20	Thermal time constant motor	s	630	
21	Ambient temperature	°C	-30...+100°C	
22	Max. permissible winding temperature	°C	+150°C	
23	Max. permissible speed	rpm	20000 rpm	
24	Radial play		preloaded	
25	Max. axial load (dynamic)	N	7,5 N	
26	Max. force for press fits (static)	N	100 N	
27	Max. radial load, 5mm from flange	N	25 N	
Other specifications				
28	Number of poles		2	
29	Number of phases		3	
30	Weight	g	317 g	

Connection

Connection		PTFE
Pin 1	+VCC	AWG20 red
Pin 2	GND	AWG20 black
Optional:		
Pin 3	FR*	AWG28 yellow

*Reverse direction when connected to GND

Gearbox combinations

- SVTG B 36
- SVTG B 42

Caution
Incorrect lead connection will damage the controller!

INTEGRATED
ELECTRONICS



ATOM SC Series
SVTN A 03 3683

24 Watt

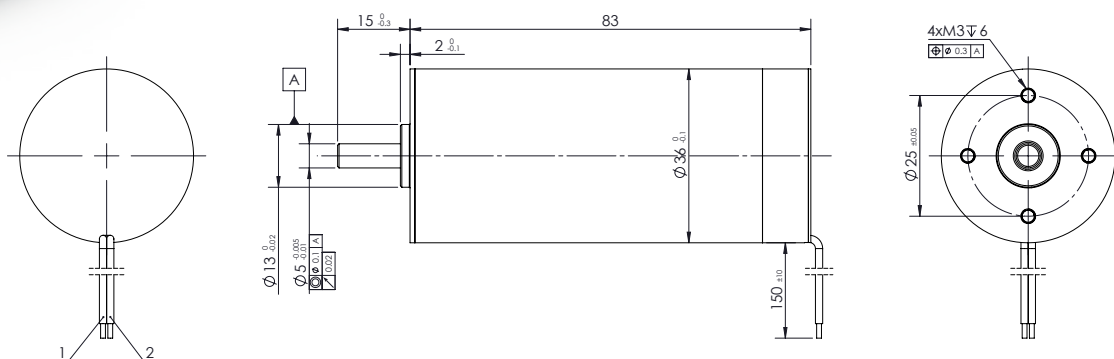

V 3

Values	Unit	SVTN A 03 3683-12..	3683-24..	
Motor Data				
1	Nominal voltage	V	12	24
2	No load speed	rpm	3278	3273
3	No load current	mA	137	78
4	Nominal speed	rpm	2294	2304
5	Nominal torque	mNm	100	100
6	Nominal current	A	3,04	1,53
7	Stall torque	mNm	333	338
8	Stall current	A	9,8	4,98
9	Max. efficiency	%	77,8	76,5
Characteristics				
10	Supply Voltage +Vcc	V	10..28	10..28
11	Direction of rotation		CCW viewed from shaft end	
12	Torque constant	mNm/A	34,5	68,9
13	Speed constant	rpm/V	277	139
14	Speed/torque gradient	rpm/mNm	9,83	9,69
15	Mechanical time constant	ms	2,2	2,2
16	Rotor inertia	gcm ²	21,5	21,5
Mechanical data				
17	Thermal resistance housing-ambient	K/W	5	
18	Thermal resistance winding-housing	K/W	2.3	
19	Thermal time constant winding	s	46	
20	Thermal time constant motor	s	816	
21	Ambient temperature	°C	-30...+100	
22	Max. permissible winding temperature	°C	+150	
23	Max. permissible speed	rpm	20000	
24	Radial play		preloaded	
25	Max. axial load (dynamic)	N	7.5	
26	Max. force for press fits (static)	N	100	
27	Max. radial load, 5mm from flange	N	25	
Other specifications				
28	Number of poles		2	
29	Number of phases		3	
30	Weight	g	366	

Connection

Connection		PTFE
Pin 1	+VCC	AWG20 red
Pin 2	GND	AWG20 black

Optional:

Pin 3	FR*	AWG28 yellow
-------	-----	--------------

*Reverse direction when connected to GND

Gearbox combinations

SVTG B 36
SVTG B 42

Caution
Incorrect lead connection will damage the controller!

ATOM DC Series

SVTN B 01

Coreless DC motors
2 Pole Brushed DC Motors

ATOM DC Series

SVTN B 01

Coreless DC motors
2 Pole Brushed DC Motors



Cost effective



High power density



Long service life



The specific design construction of a coreless DC motor provides several advantages over traditional, iron core, technology. A first added value it is given from rotor lower mass and inertia, so very rapid acceleration and deceleration rates are possible. Furthermore the lack of iron reduce "iron losses" to provide higher efficiencies (up to 90 percent) than traditional DC motors. Last, but not least, coreless design reduces winding inductance, so sparking between the brushes and commutator is reduced, increasing motor life and reducing electromagnetic interference (EMI).

Servotecnica's Coreless DC Motors are available on a wide range of sizes and high flexibility on mechanical custom requirements.

Benefits

High power density

High efficiency

High reliability

Low inductance

Low inertia

Good heat dissipation

Long operational lifetime

Cost-effective

No cogging

Product code

SVTN B 01 - ○○◇◇ - □□ - ◇ - ○△☆

B 01 Series

○ Diameter

◇ Length

□ Nominal Voltage

◇ Shaft
Single shaft [S]; Double shaft [D]

○ Connection
Terminals [0]

△ Commutator
Graphite brushes [G]; Metal brushes [M]

☆ Customizations

Features

Operating temperature	-30° +100° C
Connections	Terminals
Magnets	Neodymium
Construction technology	Coreless winding system
Estimated operating lifetime	Lifetime depends on motor working conditions. It can reach 10.000 work hours under optimal conditions (almost 100 hours under extreme conditions).

Feedback

Please contact factory for more details

Customizations

Flange	Shape
Shaft	Length/Diameter/D-Cut/double shaft
Winding	Special

Explanation of the performance diagram

The characteristic curve is composed of the following 4 key parameters:

No-load speed: It refers to the speed measured at the output shaft end when the motor is not connected to any load under the rated voltage, and the unit is RPM (revolutions per minute).

No-load current: It refers to the input current measured at the two terminals of the motor when the motor is not connected to any load at the rated voltage, and the unit is A (ampere).

Stall torque: The maximum torque measured by the motor at rated voltage due to the load causing the motor to stop rotating, in g,cm(g.cm).

Stalled current: This refers to the current measured in A (ampere) when the motor is stopped at the rated voltage due to the load.

It is recommended that you do not perform a stall operation on the motor, as this operation may cause the motor to “demagnetize” or even cause damage.

In general, the performance curve of the motor takes the output torque as the abscissa, and the speed, current, efficiency, and output power as the ordinate. correspondingly called: speed curve, current curve, efficiency curve, output power curve.

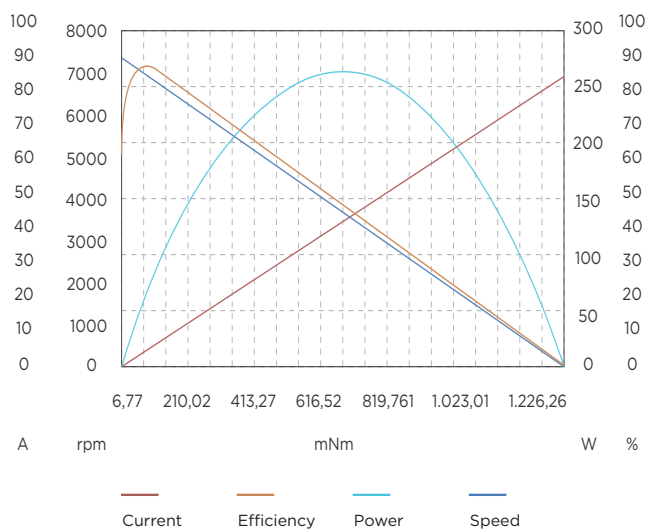

Speed curve

Is connected to the no-load speed N_0 point and stall torque T_s point. Curve, which indicates the speed of the motor under different load conditions. It is known that it decreases linearly with the increase in load.

Current curve

It is the curve shows the connection between two end points, no-load current and stall current. It describes motor current in different loading situation. As per diagram, current increase linearly with increasing torque.

Output power curve

It describes motor output power.

Efficiency curve

It describes motor efficiency and can be calculated with the following formula: $\text{Eff}(\%) = (\text{output power} / (\text{voltage} \times \text{current})) \times 100\%$. In general, the maximum efficiency point occurs in the area between stall torque/7 and stall torque/3. To design a suitable motor, maximum efficiency and maximum output power do not occur at the same point.

Table explanation

1 Nominal voltage

It is the applied voltage between two powered phases in block commutation. All nominal data (lines 2 – 9) refer to this voltage. Lower and higher voltages are permissible, provided that limits are not exceeded.

2 No load speed

It is the speed at which the unloaded motor runs with the nominal voltage applied. It is proportional to the applied voltage.

3 No load current

This is the typical current that the unloaded motor draws when operating at nominal voltage. No load friction depends heavily on temperature. It decreases in extended operation and increases at lower temperatures.

4 Nominal speed

It is the speed set for operation at nominal voltage and nominal torque at a motor temperature of 25°C.

5 Nominal torque

It is the torque generated for operation at nominal voltage and nominal current at a motor temperature of 25°C. It is at the limit of the motor's continuous operation range. Higher torques heat up the winding too much.

6 Nominal current

It is the current in the active phase the nominal torque at the given nominal speed (= max. permissible continuous load current). The maximum winding temperature is reached at 25°C ambient temperature in continuous operation with Nominal current.

7 Stall torque

It is the linearly calculated load torque for motors that causes the shaft to stall at nominal voltage. This torque often cannot be achieved due to saturation effects.

8 Stall current

It is the quotient from nominal voltage and the motor's terminal resistance. Stall current is equivalent to stall torque. With larger motors, Stall current cannot be reached due to the amplifier's current limits.

9 Max. efficiency

It is the optimal relationship between input and output power at nominal voltage. Contact factory for more detail.

10 Terminal resistance

It is determined by the resistance at 25 °C between two motor phase.

11 Terminal inductance

It is the winding inductance between two motor phase.

12 Torque constant

Represents the quotient from generated torque and applicable current.

13 Speed constant

It indicates the theoretical no load speed per volt of applied voltage, disregarding friction losses.

14 Speed/torque gradient

The speed/torque gradient is an indicator of the motor's performance. It is based on the quotient of ideal no load speed and ideal stall torque (tolerance $\pm 20\%$).

15 Mechanical time constant

It is the time required for the rotor to accelerate from standstill to 63% of its no load speed.

16 Rotor inertia

It is the mass moment of inertia of the rotor.

17 Thermal resistance housing-ambient

Characteristic values of thermal contact resistance without additional heat sinking. Lines 17 and 18 combined define the maximum heating at a given power loss (load). Thermal resistance Rth2 on motors with metal flanges can decrease by up to 80% if the motor is coupled directly to a good heat-conducting.

18 Thermal resistance winding-housing

Characteristic values of thermal contact resistance without additional heat sinking. Lines 17 and 18 combined define the maximum heating at a given power loss (load). Thermal resistance Rth2 on motors with metal flanges can decrease by up to 80% if the motor is coupled directly to a good heat-conducting.

19 Thermal time constant winding

These are the typical reaction times for a temperature change of winding and motor. It can be seen that the motor reacts much more sluggishly in thermal terms than the winding. The values are calculated from the product of thermal capacity and given heat resistances.

20 Thermal time constant motor

These are the typical reaction times for a temperature change of winding and motor. It can be seen that the motor reacts much more sluggishly in thermal terms than the winding. The values are calculated from the product of thermal capacity and given heat resistances.

21 Ambient temperature

Operating temperature range. This derives from the heat reliability of the materials.

22 Max. permissible winding temperature

Maximum permissible winding temperature.

23 Max. permissible speed

It is the maximum recommended speed based on thermal and mechanical perspectives. A reduced service life can be expected at higher speeds.

24 Max. axial load (dynamics)

Dynamic: axial loading permissible in operation. If different values apply for traction and thrust, the smaller value is given.

25 Max force for press fits (static)

Maximum axial force applying to the shaft at standstill if the force is not input at the other shaft end. This is not possible for motors with only one shaft end.

26 Max. radial load

The value is given for a typical distance from the front flange. As the distance increases, this value decreases.

27 Number of poles

Number of north poles of the permanent magnet. The phase streams and commutation signals pass through per revolution p cycles. Servo-controllers require the correct details of the number of pole pairs.

28 Weight



ATOM DC Series
SVTN B 01-1230 Metal brushes

2.5 Watt

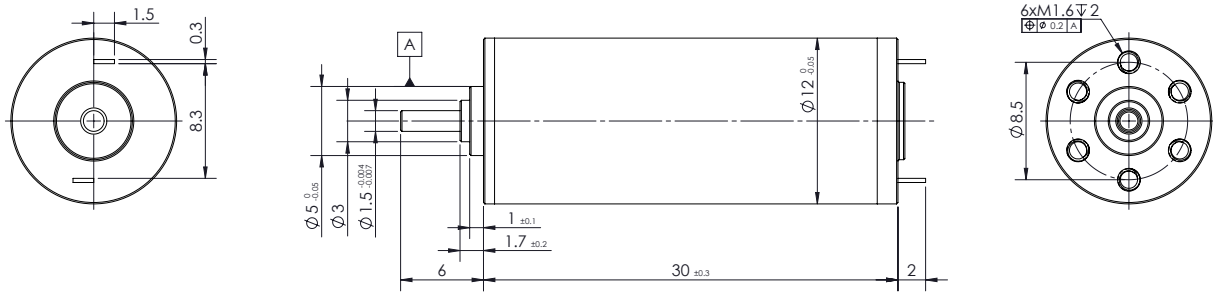

V 3

Values	Unit	SVTN B 01	1230-06..	1230-12..	1230-15..	1230-24..
Motor Data						
1	Nominal voltage	V	6	12	15	24
2	No-load speed	rpm	13500	11400	13500	15000
3	No-load current	mA	22.0	16.0	15.0	8.0
4	Nominal speed	rpm	10800	9120	10800	12000
5	Nominal torque	mNm	1.4	1.5	1.8	2.7
6	Nominal current	A	0.4	0.2	0.2	0.2
7	Stall torque	mNm	7.0	7.6	9.2	13.4
8	Stall current	A	1.69	0.78	0.89	0.90
9	Max. efficiency	%	78.5	77.7	79.9	80.0
Characteristics						
10	Terminal resistance	Ω	3.55	15.38	16.85	26.67
11	Terminal inductance	mH	0.25	0.59	0.65	0.98
12	Torque constant	mNm/A	4.19	9.91	10.49	15.11
13	Speed constant	rpm/V	2250.0	950.0	900.0	625.0
14	Speed/torque gradient	rpm/mNm	1932.1	1495.9	1462.3	1115.5
15	Mechanical time constant	ms	5.7	4.3	4.5	3.2
16	Rotor inertia	gcm ²	0.28	0.27	0.29	0.27
Mechanical data						
17	Thermal resistance housing-ambient				33 K/W	
18	Thermal resistance winding-housing				7.0 K/W	
19	Thermal time constant winding				4.88 s	
20	Thermal time constant motor				229 s	
21	Ambient temperature				-20...+85°C	
22	Max. permissible winding temperature				+100°C	
23	Max. permissible speed				15000 rpm	
24	Max. axial load (dynamic)				0,1 N	
25	Max. force for press fits (static)				20 N	
26	Max. radial load, 5mm from flange				5 N	
Other specifications						
27	Number of poles				2	
28	Weight				17 gr	

Gearbox combinations

- SVTG B 10*
- SVTG B 12*

*On request



ATOM DC Series
SVTN B 01-1320 Metal brushes

1.1 Watt

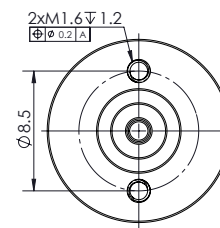
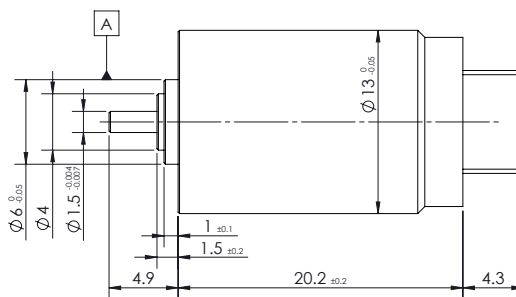
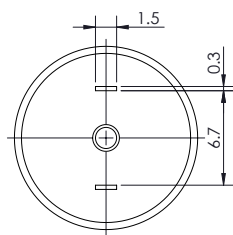

V 3

Values	Unit	SVTN B 01	1320-3.7..	1320-06..	1320-12..	1320-24..
Motor Data						
1	Nominal voltage	V	3.7	6	12	24
2	No-load speed	rpm	9500	12000	13000	12000
3	No-load current	mA	35.0	30	16	10
4	Nominal speed	rpm	7600	9600	10400	9600
5	Nominal torque	mNm	0.9	1.5	1.0	1.19
6	Nominal current	A	0.288	0.358	0.133	0.074
7	Stall torque	mNm	4.58	7.41	5.01	5.93
8	Stall current	A	1.30	1.63	0.60	0.33
9	Max. efficiency	%	69.9	71.1	70.0	68.21
Characteristics						
10	Terminal resistance	Ω	2.85	3.68	20	72.73
11	Terminal inductance	mH	0.09	0.12	0.50	1.30
12	Torque constant	mNm/A	3.62	4.66	8.58	18.52
13	Speed constant	rpm/V	2567.6	2000.0	1083.3	500.00
14	Speed/torque gradient	rpm/mNm	2075.1	1620.4	2594.5	2024.85
15	Mechanical time constant	ms	5.3	4.2	5.6	4.63
16	Rotor inertia	gcm ²	0.25	0.25	0.20	0.22
Mechanical data						
17	Thermal resistance housing-ambient				46 K/W	
18	Thermal resistance winding-housing				14 K/W	
19	Thermal time constant winding				5.18 s	
20	Thermal time constant motor				76.1 s	
21	Ambient temperature				-20...+85°C	
22	Max. permissible winding temperature				+100°C	
23	Max. permissible speed				19000 rpm	
24	Max. axial load (dynamic)				0.2 N	
25	Max. force for press fits (static)				20 N	
26	Max. radial load, 5mm from flange				1.4 N	
Other specifications						
27	Number of poles				2	
28	Weight				13 gr	

Gearbox combinations

- SVTG B 10*
- SVTG B 12*

*On request



ATOM DC Series SVTN B 01-1331 Metal brushes

3.5 Watt

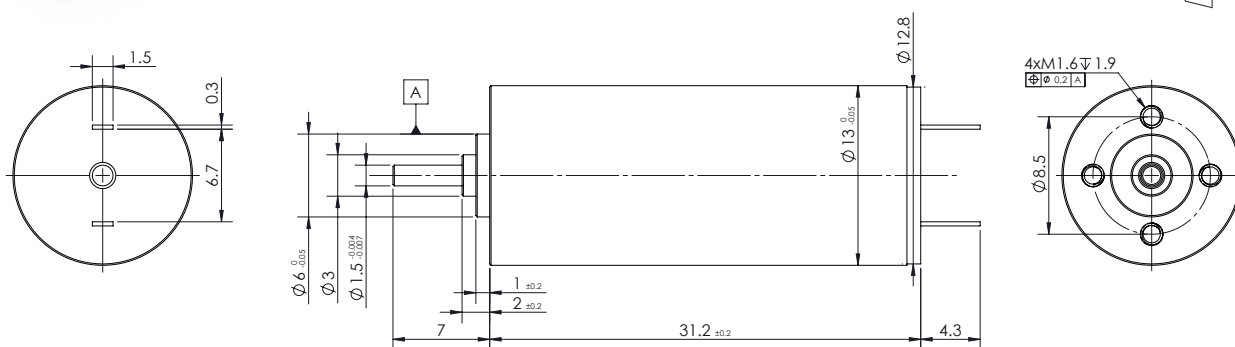

V 3

Values	Unit	SVTN B 01	1331-3..	1331-06..	1331-12..	1331-24..
Motor Data						
1	Nominal voltage	V	3	6	12	24
2	No-load speed	rpm	12000	11000	11600	16200
3	No-load current	mA	45.0	30.0	18.0	12.0
4	Nominal speed	rpm	9600	8800	9280	12960
5	Nominal torque	mNm	2.1	2.4	2.0	4.1
6	Nominal current	A	0.9	0.5	0.2	0.4
7	Stall torque	mNm	10.3	12.1	10.1	21.0
8	Stall current	A	4.400	2.400	1.080	1.570
9	Max. efficiency	%	80.8	75.8	69.4	70.5
Characteristics						
10	Terminal resistance	Ω	0.68	2.50	11.11	12.31
11	Terminal inductance	mH	0.05	0.12	0.27	0.75
12	Torque constant	mNm/A	2.36	5.12	9.60	13.78
13	Speed constant	rpm/V	4000.0	1833.3	966.7	675.0
14	Speed/torque gradient	rpm/mNm	1166.1	910.0	1150.3	618.5
15	Mechanical time constant	ms	8.0	6.2	7.9	4.2
16	Rotor inertia	gcm ²	0.65	0.65	0.65	0.65
Mechanical data						
17	Thermal resistance housing-ambient				33 K/W	
18	Thermal resistance winding-housing				7.0 K/W	
19	Thermal time constant winding				4.88 s	
20	Thermal time constant motor				259 s	
21	Ambient temperature				-20...+85°C	
22	Max. permissible winding temperature				+100°C	
23	Max. permissible speed				16200 rpm	
24	Max. axial load (dynamic)				0.2 N	
25	Max. force for press fits (static)				20 N	
26	Max. radial load, 5mm from flange				1.4 N	
Other specifications						
27	Number of poles				2	
28	Weight				20 gr	

Gearbox combinations

SVTG B 10*

SVTG B 12*

*On request



ATOM DC Series
SVTN B 01-1524 Metal brushes

2.2 Watt

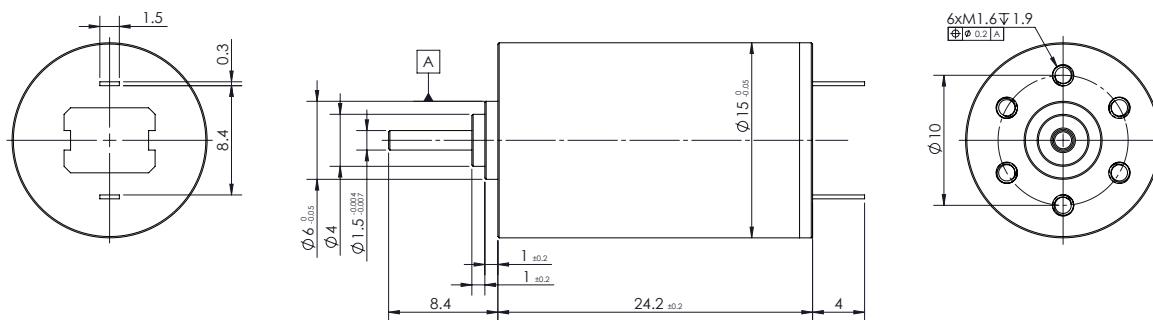

V 3

Values	Unit	SVTN B 01	1524-03..	1524-06..	1524-12..	1524-24..
Motor Data						
1	Nominal voltage	V	3	6	12	24
2	No-load speed	rpm	10700	12300	11800	9500
3	No-load current	mA	40	20	11	4
4	Nominal speed	rpm	8560	9840	9440	7600
5	Nominal torque	mNm	1.6	1.8	1.7	1.4
6	Nominal current	A	0.6	0.4	0.2	0.1
7	Stall torque	mNm	7.8	9.1	8.7	7.0
8	Stall current	A	3.0	2.0	0.9	0.3
9	Max. efficiency	%	78.2	81.0	79.3	78.2
Characteristics						
10	Terminal resistance	Ω	1.00	3.00	13.04	80.00
11	Terminal inductance	mH	0.02	0.05	0.23	1.05
12	Torque constant	mNm/A	2.64	4.61	9.60	23.80
13	Speed constant	rpm/V	3566.7	2050.0	983.3	395.8
14	Speed/torque gradient	rpm/mNm	1368.4	1347.1	1352.9	1348.3
15	Mechanical time constant	ms	11.0	10.1	11.9	11.9
16	Rotor inertia	gcm ²	0.77	0.72	0.84	0.84
Mechanical data						
17	Thermal resistance housing-ambient				4.5 K/W	
18	Thermal resistance winding-housing				31 K/W	
19	Thermal time constant winding				2.4 s	
20	Thermal time constant motor				300 s	
21	Ambient temperature				-20...+85°C	
22	Max. permissible winding temperature				+100°C	
23	Max. permissible speed				12300 rpm	
24	Max. axial load (dynamic)				0.2 N	
25	Max. force for press fits (static)				20 N	
26	Max. radial load, 5mm from flange				1.4 N	
Other specifications						
27	Number of poles				2	
28	Weight				22 gr	

Gearbox combinations

SVTG A 16



ATOM DC Series
SVTN B 01-1625 Metal brushes

2.8 Watt

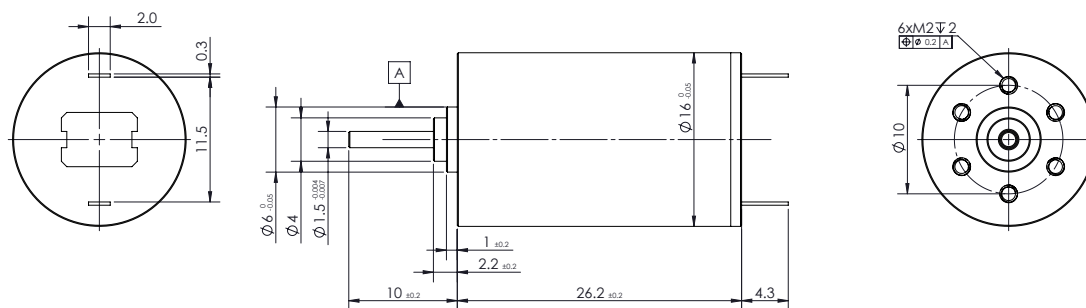

V 3

Values	Unit	SVTN B 01	1625-3.7..	1625-06..	1625-12..	1625-24..
Motor Data						
1	Nominal voltage	V	3.7	6	12	24
2	No-load speed	rpm	8500	9800	10800	11000
3	No-load current	mA	50	20	15	6
4	Nominal speed	rpm	6800	7840	8640	8800
5	Nominal torque	mNm	2.5	2.8	2.7	3.0
6	Nominal current	A	0.67	0.50	0.27	0.15
7	Stall torque	mNm	12.7	14.0	13.5	15.2
8	Stall current	A	3.15	2.43	1.30	0.74
9	Max. efficiency	%	76.4	82.7	79.7	82.8
Characteristics						
10	Terminal resistance	Ω	1.17	2.47	9.23	32.43
11	Terminal inductance	mH	0.105	0.210	0.510	1.320
12	Torque constant	mNm/A	4.09	5.80	10.49	20.67
13	Speed constant	rpm/V	2297.3	1633.3	900.0	458.3
14	Speed/torque gradient	rpm/mNm	670.3	701.3	801.4	725.2
15	Mechanical time constant	ms	6.3	6.6	7.5	6.8
16	Rotor inertia	gcm ²	0.90	0.90	0.90	0.90
Mechanical data						
17	Thermal resistance housing-ambient				40.6 K/W	
18	Thermal resistance winding-housing				9.5 K/W	
19	Thermal time constant winding				5.33 s	
20	Thermal time constant motor				268 s	
21	Ambient temperature				-20...+85°C	
22	Max. permissible winding temperature				+100°C	
23	Max. permissible speed				11000 rpm	
24	Max. axial load (dynamic)				1.3 N	
25	Max. force for press fits (static)				15 N	
26	Max. radial load, 5mm from flange				5 N	
Other specifications						
27	Number of poles				2	
28	Weight				24 gr	

Gearbox combinations

SVTG A 16



ATOM DC Series
SVTN B 01-1625 Graphite brushes

2.8 Watt

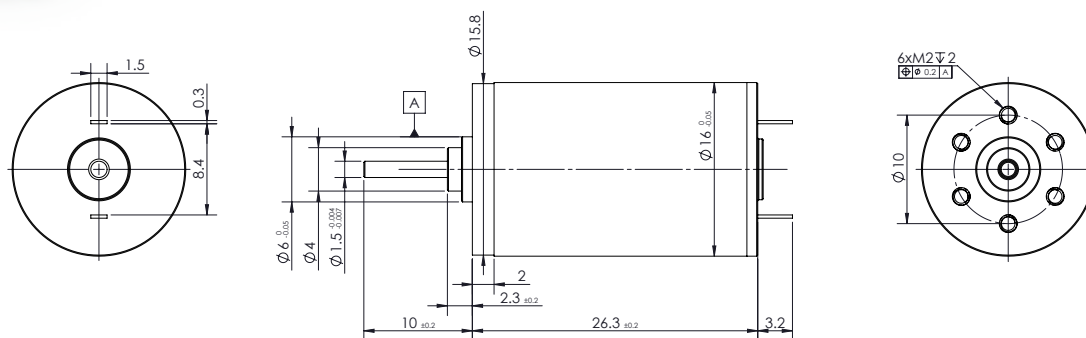
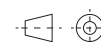

V 3

Values	Unit	SVTN B 01				
		1625-06-..	1625-09-..	1625-12-..	1625-24-..	
Motor Data						
1	Nominal voltage	V	6	9	12	24
2	No-load speed	rpm	11500	12500	13600	11800
3	No-load current	mA	80	65	50	32
4	Nominal speed	rpm	8108	9125	9928	8614
5	Nominal torque	mNm	2.71	3.10	3.19	3.64
6	Nominal current	A	0.65	0.53	0.44	0.23
7	Stall torque	mNm	9.2	11.5	11.8	13.5
8	Stall current	A	2.00	1.80	1.50	0.82
9	Max. efficiency	%	64.0	65.6	66.8	66.2
Characteristics						
10	Terminal resistance	Ω	3.00	5.00	8.00	29.30
11	Terminal inductance	mH	0.10	0.18	0.34	1.10
12	Torque constant	mNm/A	4.78	6.63	8.14	18.75
13	Speed constant	rpm/V	1916.7	1388.9	1133.3	491.7
14	Speed/torque gradient	rpm/mNm	1252.3	1087.1	1151.5	708.8
15	Mechanical time constant	ms	12.6	10.7	10.8	7.6
16	Rotor inertia	gcm ²	0.96	0.94	0.90	1.03
Mechanical data						
17	Thermal resistance housing-ambient			40.6 K/W		
18	Thermal resistance winding-housing			9.5 K/W		
19	Thermal time constant winding			5.33 s		
20	Thermal time constant motor			268 s		
21	Ambient temperature			-20...+85°C		
22	Max. permissible winding temperature			+100°C		
23	Max. permissible speed			13600 rpm		
24	Max. axial load (dynamic)			1.3 N		
25	Max. force for press fits (static)			15 N		
26	Max. radial load, 5mm from flange			5 N		
Other specifications						
27	Number of poles			2		
28	Weight			24 gr		

Gearbox combinations

SVTG A 16

CORELESS
BRUSHED DC

servotecnica



ATOM DC Series
SVTN B 01-1640 Metal brushes

11.3 Watt

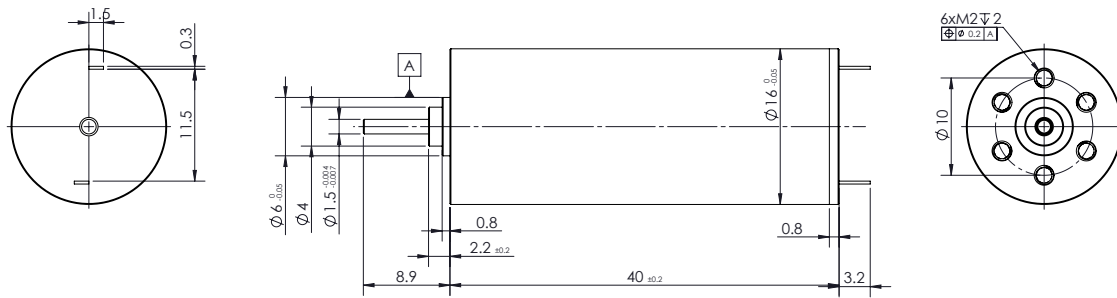

V 3

Values	Unit	SVTN B 01	1640-03..	1640-06..	1640-12..	1640-24..
Motor Data						
1	Nominal voltage	V	3	6	12	24
2	No-load speed	rpm	10000	9200	14000	13000
3	No-load current	mA	50	28	60	25
4	Nominal speed	rpm	8000	7360	11200	10400
5	Nominal torque	mNm	3.1	3.3	10.0	10.4
6	Nominal current	A	1.14	0.56	1.29	0.62
7	Stall torque	mNm	15.5	16.3	49.8	52.0
8	Stall current	A	5.5	2.7	6.2	3.0
9	Max. efficiency	%	81.8	80.6	81.3	82.6
Characteristics						
10	Terminal resistance	Ω	0.55	2.25	1.94	8.00
11	Terminal inductance	mH	0.01	0.06	0.15	0.56
12	Torque constant	mNm/A	2.84	6.16	8.11	17.48
13	Speed constant	rpm/V	3333.3	1533.3	1166.7	541.7
14	Speed/torque gradient	rpm/mNm	646.4	565.1	281.3	249.9
15	Mechanical time constant	ms	11.3	9.9	4.9	4.4
16	Rotor inertia	gcm ²	1.67	1.67	0.90	1.67
Mechanical data						
17	Thermal resistance housing-ambient				30 K/W	
18	Thermal resistance winding-housing				8.5 K/W	
19	Thermal time constant winding				10.6 s	
20	Thermal time constant motor				436 s	
21	Ambient temperature				-20...+85°C	
22	Max. permissible winding temperature				+100°C	
23	Max. permissible speed				14000 rpm	
24	Max. axial load (dynamic)				1.3 N	
25	Max. force for press fits (static)				15 N	
26	Max. radial load, 5mm from flange				5 N	
Other specifications						
27	Number of poles				2	
28	Weight				40.5 gr	

Gearbox combinations

SVTG A 16



ATOM DC Series
SVTN B 01-1725 Metal brushes

2.9 Watt

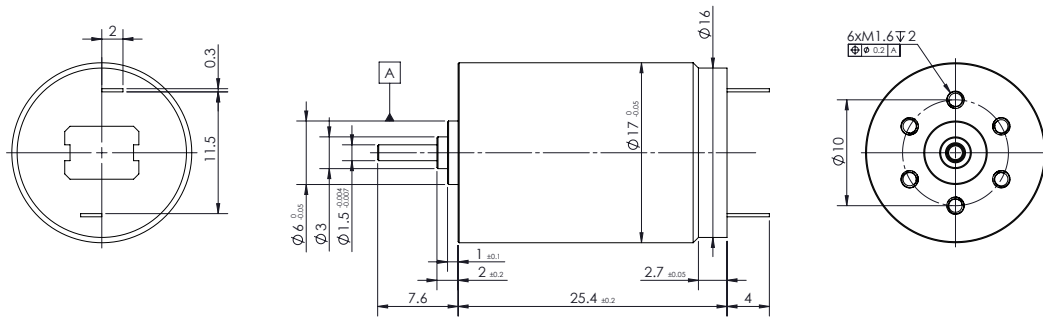

V 3

Values	Unit	SVTN B 01 1725-06..	1725-09..	1725-12..	1725-24..	
Motor Data						
1	Nominal voltage	V	6	9	12	24
2	No-load speed	rpm	10000	10000	10000	10000
3	No-load current	mA	23	30	20	8
4	Nominal speed	rpm	8000	8000	8000	8000
5	Nominal torque	mNm	2.19	2.06	2.68	2.72
6	Nominal current	A	0.41	0.28	0.24	0.14
7	Stall torque	mNm	11.0	10.3	13.4	13.6
8	Stall current	A	1.96	1.26	1.21	0.61
9	Max. efficiency	%	79.5	71.5	77.5	81.4
Characteristics						
10	Terminal resistance	Ω	3.06	7.14	5.71	22.86
11	Terminal inductance	mH	0.10	0.20	0.28	0.93
12	Torque constant	mNm/A	5.66	8.39	11.30	22.70
13	Speed constant	rpm/V	1666.7	1111.1	833.3	416.7
14	Speed/torque gradient	rpm/mNm	911.7	969.1	746.0	735.0
15	Mechanical time constant	ms	7.4	7.9	4.2	3.6
16	Rotor inertia	gcm ²	0.78	0.78	0.80	0.82
Mechanical data						
17	Thermal resistance housing-ambient			4 K/W		
18	Thermal resistance winding-housing			24.5 K/W		
19	Thermal time constant winding			2.6 s		
20	Thermal time constant motor			270 s		
21	Ambient temperature			-20...+85°C		
22	Max. permissible winding temperature			+100°C		
23	Max. permissible speed			10000 rpm		
24	Max. axial load (dynamic)			1.3 N		
25	Max. force for press fits (static)			15 N		
26	Max. radial load, 5mm from flange			5 N		
Other specifications						
27	Number of poles			2		
28	Weight			28 gr		

Gearbox combinations

SVTG A 16



ATOM DC Series
SVTN B 01-1725 Graphite brushes

3.9 Watt

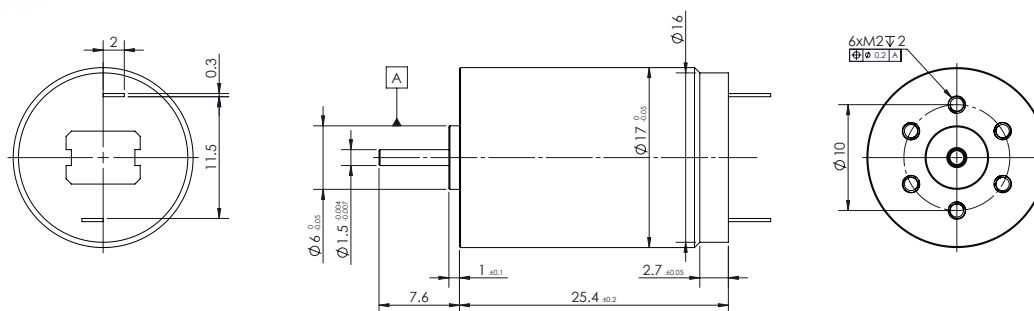

V 3

Values	Unit	SVTN B 01	1725-06..	1725-12..	1725-24..
Motor Data					
1	Nominal voltage	V	6	12	24
2	No-load speed	rpm	11000	10000	10000
3	No-load current	mA	90	50	22
4	Nominal speed	rpm	8140	7400	7300
5	Nominal torque	mNm	3.55	3.28	3.81
6	Nominal current	A	0.79	0.35	0.19
7	Stall torque	mNm	13.66	12.60	14.10
8	Stall current	A	2.80	1.17	0.66
9	Max. efficiency	%	67.4	67.8	66.6
Characteristics					
10	Terminal resistance	Ω	2.14	10.20	36.40
11	Terminal inductance	mH	0.08	0.31	1.18
12	Torque constant	mNm/A	5.04	11.10	22.14
13	Speed constant	rpm/V	1833.3	833.3	416.7
14	Speed/torque gradient	rpm/mNm	805.2	793.6	584.2
15	Mechanical time constant	ms	7.6	5.5	5.5
16	Rotor inertia	gcm ²	0.90	0.90	0.90
Mechanical data					
17	Thermal resistance housing-ambient			4 K/W	
18	Thermal resistance winding-housing			24.5 K/W	
19	Thermal time constant winding			2.6 s	
20	Thermal time constant motor			270 s	
21	Ambient temperature			-20...+85°C	
22	Max. permissible winding temperature			+100°C	
23	Max. permissible speed			11000 rpm	
24	Max. axial load (dynamic)			1.3 N	
25	Max. force for press fits (static)			15 N	
26	Max. radial load, 5mm from flange			5 N	
Other specifications					
27	Number of poles			2	
28	Weight			28 gr	

Gearbox combinations

SVTG A 16



ATOM DC Series
SVTN B 01-1740 Graphite brushes

14 Watt

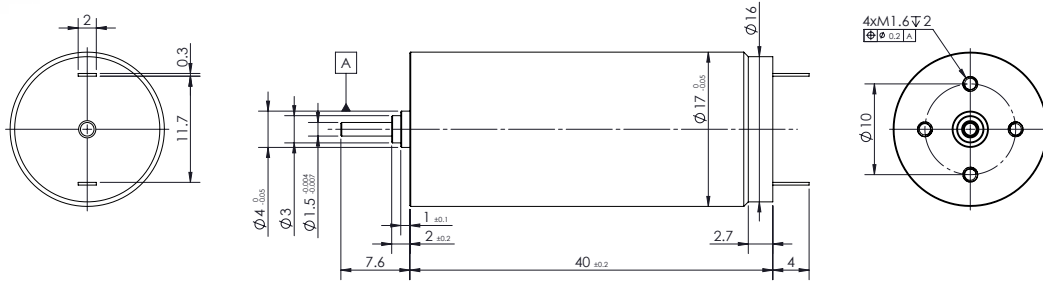

V 3

Values	Unit	SVTN B 01	1740-06..	1740-12..	1740-24..
Motor Data					
1	Nominal voltage	V	6	12	24
2	No-load speed	rpm	13500	22000	16000
3	No-load current	mA	120	130	48
4	Nominal speed	rpm	11408	18590	13520
5	Nominal torque	mNm	6.0	9.5	9.8
6	Nominal current	A	1.54	1.97	0.74
7	Stall torque	mNm	38.5	61.2	63.1
8	Stall current	A	9.30	12.00	4.50
9	Max. efficiency	%	78.6	80.3	80.4
Characteristics					
10	Terminal resistance	Ω	0.65	1.00	5.33
11	Terminal inductance	mH	0.028	0.075	0.290
12	Torque constant	mNm/A	4.19	5.15	14.17
13	Speed constant	rpm/V	2250.0	1833.3	666.7
14	Speed/torque gradient	rpm/mNm	351.0	359.7	253.6
15	Mechanical time constant	ms	6.2	6.4	4.5
16	Rotor inertia	gcm ²	1.69	1.69	1.69
Mechanical data					
17	Thermal resistance housing-ambient			7 K/W	
18	Thermal resistance winding-housing			23 K/W	
19	Thermal time constant winding			8 s	
20	Thermal time constant motor			440 s	
21	Ambient temperature			-20...+85°C	
22	Max. permissible winding temperature			+100°C	
23	Max. permissible speed			22000 rpm	
24	Max. axial load (dynamic)			1.3 N	
25	Max. force for press fits (static)			15 N	
26	Max. radial load, 5mm from flange			5 N	
Other specifications					
27	Number of poles			2	
28	Weight			48 gr	

Gearbox combinations

SVTG A 16



ATOM DC Series
SVTN B 01-2225 Metal brushes

4.2 Watt

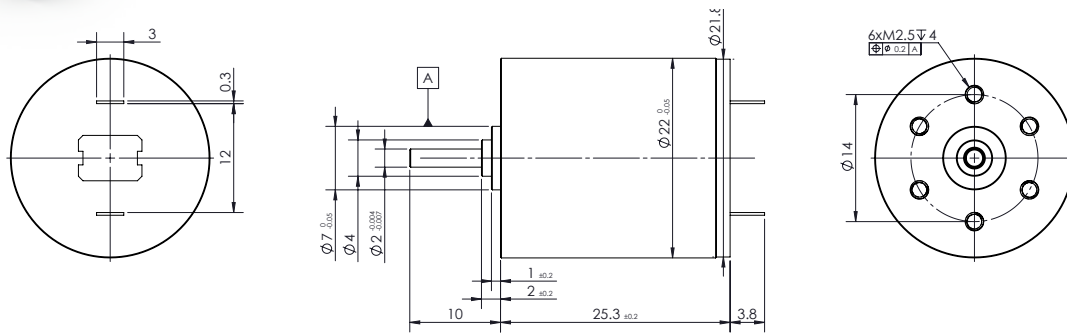
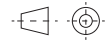

V 3

Values	Unit	SVTN B 01					
		2225-03..	2225-06..	2225-09..	2225-12..	2225-24..	
Motor Data							
1	Nominal voltage	V	3	6	9	12	24
2	No-load speed	rpm	7600	8200	8500	8300	7800
3	No-load current	mA	70	30	25	20	6
4	Nominal speed	rpm	6764	6806	7480	6889	6474
5	Nominal torque	mNm	2.35	3.28	2.60	4.13	3.44
6	Nominal current	A	0.70	0.50	0.29	0.32	0.12
7	Stall torque	mNm	21.3	19.3	21.7	24.3	20.2
8	Stall current	A	5.80	2.82	2.20	1.80	0.70
9	Max. efficiency	%	79.2	80.4	79.5	80.0	82.3
Characteristics							
10	Terminal resistance	Ω	0.52	2.13	4.09	6.67	34.29
11	Terminal inductance	mH	0.013	0.045	0.095	0.240	0.800
12	Torque constant	mNm/A	3.72	6.91	10.00	13.65	29.13
13	Speed constant	rpm/V	2533.3	1366.7	944.0	691.7	325.0
14	Speed/torque gradient	rpm/mNm	356.2	425.2	390.9	341.5	385.8
15	Mechanical time constant	ms	9.93	12.30	10.20	10.61	11.84
16	Rotor inertia	gcm ²	2.66	2.76	2.79	2.97	2.93
Mechanical data							
17	Thermal resistance housing-ambient				20 K/W		
18	Thermal resistance winding-housing				6.0 K/W		
19	Thermal time constant winding				10.2 s		
20	Thermal time constant motor				313 s		
21	Ambient temperature				-20...+85°C		
22	Max. permissible winding temperature				+100°C		
23	Max. permissible speed				8300 rpm		
24	Max. axial load (dynamic)				3.5 N		
25	Max. force for press fits (static)				44 N		
26	Max. radial load, 5mm from flange				15 N		
Other specifications							
27	Number of poles				2		
28	Weight				48 gr		

Gearbox combinations

- SVTG B 22
- SVTG B 24



ATOM DC Series
SVTN B 01-2225 Graphite brushes

8.1 Watt

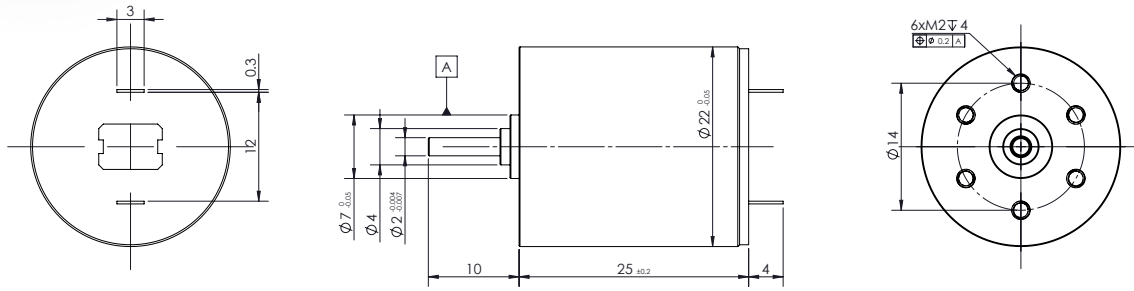

V 3

Values	Unit	SVTN B 01 2225-06..	2225-12..	2225-18..	2225-24..	
Motor Data						
1	Nominal voltage	V	6	12	18	24
2	No-load speed	rpm	13500	15800	11800	12000
3	No-load current	mA	100	90	60	45
4	Nominal speed	rpm	11340	13272	9676	9960
5	Nominal torque	mNm	3.67	5.13	6.24	5.56
6	Nominal current	A	0.98	0.81	0.50	0.34
7	Stall torque	mNm	22.9	32.1	34.7	32.7
8	Stall current	A	5.60	4.60	2.50	1.80
9	Max. efficiency	%	75.1	74.0	71.4	70.9
Characteristics						
10	Terminal resistance	Ω	1.07	2.61	7.20	13.33
11	Terminal inductance	mH	0.025	0.090	0.265	0.550
12	Torque constant	mNm/A	4.17	7.11	14.22	18.62
13	Speed constant	rpm/V	2250.0	1316.7	655.6	500.0
14	Speed/torque gradient	rpm/mNm	588.9	492.7	340.2	367.2
15	Mechanical time constant	ms	18.07	15.12	10.44	11.27
16	Rotor inertia	gcm ²	2.93	2.93	2.97	2.93
Mechanical data						
17	Thermal resistance housing-ambient				20 K/W	
18	Thermal resistance winding-housing				6.0 K/W	
19	Thermal time constant winding				10.2 s	
20	Thermal time constant motor				313 s	
21	Ambient temperature				-20...+85°C	
22	Max. permissible winding temperature				+100°C	
23	Max. permissible speed				15800 rpm	
24	Max. axial load (dynamic)				3.5 N	
25	Max. force for press fits (static)				44 N	
26	Max. radial load, 5mm from flange				15 N	
Other specifications						
27	Number of poles				2	
28	Weight				48 gr	

Gearbox combinations

- SVTG B 22
- SVTG B 24



ATOM DC Series
SVTN B 01-2230 Metal brushes

5.5 Watt

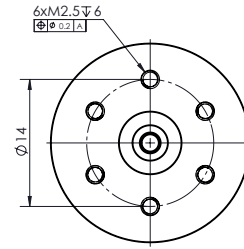
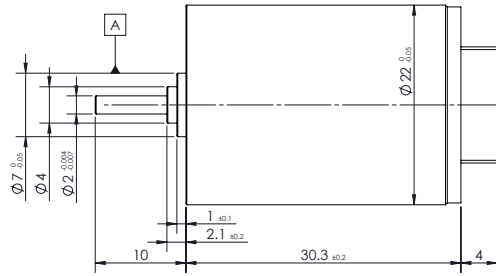
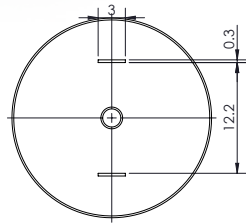
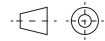

V 3

Values	Unit	SVTN B 01					
		2230-06..	2230-09..	2230-12..	2230-15..	2230-24..	
Motor Data							
1	Nominal voltage	V	6	9	12	15	24
2	No-load speed	rpm	8300	12200	10200	11000	9000
3	No-load current	mA	48	60	24	8	6
4	Nominal speed	rpm	7387	10858	9078	9790	8010
5	Nominal torque	mNm	2,81	2,39	2,73	2,7	1,37
6	Nominal current	A	0,46	0,41	0,27	0,22	0,06
7	Stall torque	mNm	25,6	21,7	24,9	24,5	12,4
8	Stall current	A	3,8	3,2	2,26	1,9	0,5
9	Max. efficiency	%	78,8	74,5	80,4	87,4	79,3
Characteristics							
10	Terminal resistance	Ω	1,58	2,81	5,31	7,89	48
11	Terminal inductance	mH	0,095	0,16	0,36	0,58	3,1
12	Torque constant	mNm/A	6,82	6,91	11,12	12,97	25,2
13	Speed constant	rpm/V	1383,3	1355,6	850	733,3	375
14	Speed/torque gradient	rpm/mNm	324,6	562,1	410,4	448,4	724,1
15	Mechanical time constant	ms	8,94	13,83	10,63	11,9	20,18
16	Rotor inertia	gcm ²	2,63	2,35	2,47	2,54	2,75
Mechanical data							
17	Thermal resistance housing-ambient				20 K/W		
18	Thermal resistance winding-housing				6.0 K/W		
19	Thermal time constant winding				10.2 s		
20	Thermal time constant motor				313 s		
21	Ambient temperature				-20...+85°C		
22	Max. permissible winding temperature				+100°C		
23	Max. permissible speed				12200 rpm		
24	Max. axial load (dynamic)				3,5 N		
25	Max. force for press fits (static)				44 N		
26	Max. radial load, 5mm from flange				15 N		
Other specifications							
27	Number of poles				2		
28	Weight				54 gr		

Gearbox combinations

- SVTG B 22
- SVTG B 24

CORELESS
BRUSHED DC

servotecnica



ATOM DC Series

SVTN B 01-2230 Graphite brushes

7 Watt

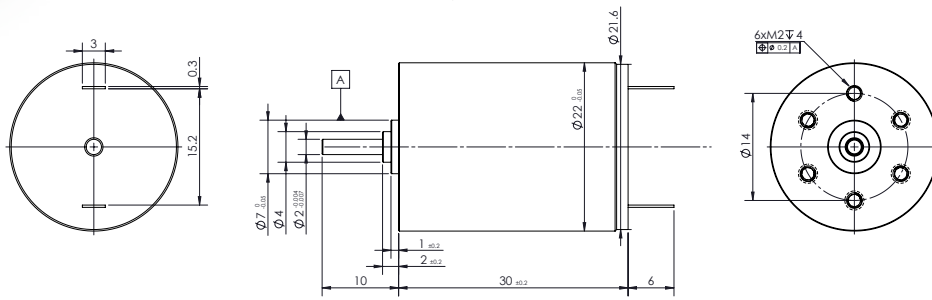

V 3

Values	Unit	SVTN B 01 2230-06..	2230-12..	2230-18..	2230-24..	
Motor Data						
1	Nominal voltage	V	6	12	18	24
2	No-load speed	rpm	11300	12200	10800	11000
3	No-load current	mA	90	65	45	30
4	Nominal speed	rpm	9492	10248	9234	9405
5	Nominal torque	mNm	3,91	5,22	5,79	5,26
6	Nominal current	A	0,88	0,63	0,42	0,29
7	Stall torque	mNm	24,45	32,6	39,96	36,26
8	Stall current	A	5	3,6	2,6	1,8
9	Max. efficiency	%	74,97	74,93	75,42	75,85
Characteristics						
10	Terminal resistance	Ω	1,2	3,33	6,92	13,33
11	Terminal inductance	mH	0,19	0,403	0,85	1,6
12	Torque constant	mNm/A	4,98	9,22	15,64	20,49
13	Speed constant	rpm/V	1883,3	1016,7	600	458,3
14	Speed/torque gradient	rpm/mNm	462,2	374,2	270,3	303,3
15	Mechanical time constant	ms	13,05	11,08	7,9	9,09
16	Rotor inertia	gcm ²	2,7	2,83	2,79	2,54
Mechanical data						
17	Thermal resistance housing-ambient				20 K/W	
18	Thermal resistance winding-housing				6.0 K/W	
19	Thermal time constant winding				10.2 s	
20	Thermal time constant motor				314 s	
21	Ambient temperature				-20...+85°C	
22	Max. permissible winding temperature				+100°C	
23	Max. permissible speed				12200 rpm	
24	Max. axial load (dynamic)				3,5 N	
25	Max. force for press fits (static)				44 N	
26	Max. radial load, 5mm from flange				15 N	
Other specifications						
27	Number of poles				2	
28	Weight				54 gr	

Gearbox combinations

- SVTG B 22
- SVTG B 24

35 Watt



ATOM DC Series
SVTN B 01-2864 Graphite brushes

servotecnica

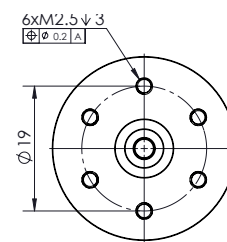
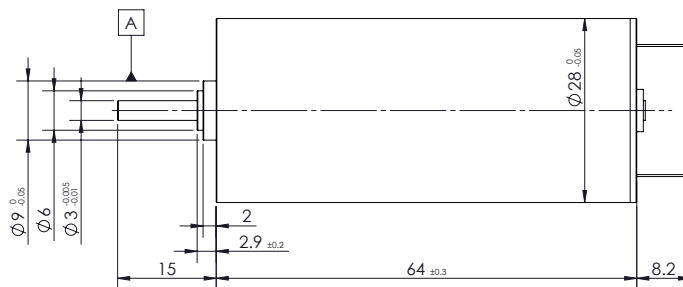
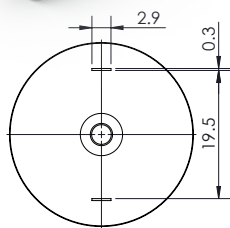

V 3

Values	Unit	SVTN B 01 2864-06..	2864-12..	2864-24..	
Motor Data					
1	Nominal voltage	V	6	12	24
2	No-load speed	rpm	7500	7300	7300
3	No-load current	mA	320	240	64
4	Nominal speed	rpm	6675	6497	6497
5	Nominal torque	mNm	19,63	26,46	32,71
6	Nominal current	A	2,92	1,95	1,11
7	Stall torque	mNm	178,5	240,5	297,4
8	Stall current	A	24	15,8	9,6
9	Max. efficiency	%	78,2	76,9	84,3
Characteristics					
10	Terminal resistance	Ω	0,25	0,76	2,5
11	Terminal inductance	mH	0,03	0,09	0,28
12	Torque constant	mNm/A	7,54	15,46	31,19
13	Speed constant	rpm/V	1250	608,3	304,2
14	Speed/torque gradient	rpm/mNm	42	30,3	24,5
15	Mechanical time constant	ms	7,02	6,56	4,97
16	Rotor inertia	gcm ²	15,94	20,63	19,32
Mechanical data					
17	Thermal resistance housing-ambient			8 K/W	
18	Thermal resistance winding-housing			3 K/W	
19	Thermal time constant winding			30 s	
20	Thermal time constant motor			600 s	
21	Ambient temperature			-20...+85°C	
22	Max. permissible winding temperature			+100°C	
23	Max. permissible speed			7500 rpm	
24	Max. axial load (dynamic)			7,5 N	
25	Max. force for press fits (static)			100 N	
26	Max. radial load, 5mm from flange			25 N	
Other specifications					
27	Number of poles			2	
28	Weight			200 gr	

Gearbox combinations

- SVTG B 28
- SVTG B 32

CORELESS
BRUSHED DC



ATOM DC Series
SVTN B 01-3571 Graphite brushes

85 Watt

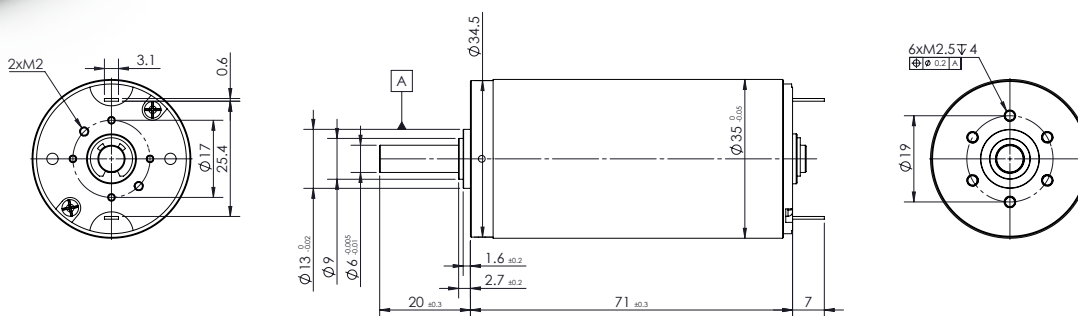

V 3

Values	Unit	SVTN B 01					
		3571-12..	3571-15..	3571-18..	3571-24..	3571-48..	
Motor Data							
1	Nominal voltage	V	12	15	18	24	48
2	No-load speed	rpm	7400	7100	6600	7900	7600
3	No-load current	mA	250	160	150	150	80
4	Nominal speed	rpm	6771	6497	6039	7229	6118
5	Nominal torque	mNm	115,17	81,76	82,35	117,62	125,69
6	Nominal current	A	7,71	4,23	3,32	4,22	2,17
7	Stall torque	mNm	1355	961,9	968,8	1383,8	1256,9
8	Stall current	A	88	48	37,5	48	21
9	Max. efficiency	%	89,6	88,8	87,8	89,1	88
Characteristics							
10	Terminal resistance	Ω	0,14	0,31	0,48	0,5	2,3
11	Terminal inductance	mH	0,05	0,12	0,17	0,19	0,8
12	Torque constant	mNm/A	15,44	20,11	25,94	28,92	60,1
13	Speed constant	rpm/V	616,7	473,3	366,7	329,2	158,3
14	Speed/torque gradient	rpm/mNm	5,5	7,4	6,8	5,7	6
15	Mechanical time constant	ms	4,57	5,87	5,43	4,48	5,06
16	Rotor inertia	gcm ²	79,98	76,01	76,06	74,80	79,98
Mechanical data							
17	Thermal resistance housing-ambient				6,2 K/W		
18	Thermal resistance winding-housing				2 K/W		
19	Thermal time constant winding				30,1 s		
20	Thermal time constant motor				707 s		
21	Ambient temperature				-20...+85°C		
22	Max. permissible winding temperature				+100°C		
23	Max. permissible speed				7900 rpm		
24	Max. axial load (dynamic)				7,5 N		
25	Max. force for press fits (static)				100 N		
26	Max. radial load, 5mm from flange				25 N		
Other specifications							
27	Number of poles				2		
28	Weight				360 gr		

Gearbox combinations

- SVTG B 36
- SVTG B 42



ATOM DC Series
SVTN B 01-4050 Graphite brushes

87 Watt

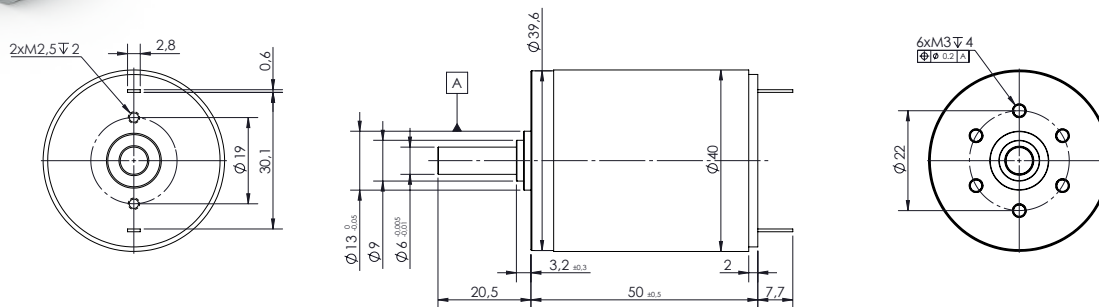

V 3

Values	Unit	SVTN B 01 4050-12..	4050-15..	4050-24..	4050-36..	4050-48..	
Motor Data							
1	Nominal voltage	V	12	15	24	36	48
2	No-load speed	rpm	7600	7600	7850	8000	9500
3	No-load current	mA	260	200	150	60	40
4	Nominal speed	rpm	6612	6612	6712	6640	8075
5	Nominal torque	mNm	57,79	57,83	77,05	72,18	75,41
6	Nominal current	A	4,13	3,29	2,81	1,75	1,61
7	Stall torque	mNm	444,5	444,8	531,4	424,6	502,8
8	Stall current	A	30	24	18,5	10	10,5
9	Max. efficiency	%	82,2	82,6	82,8	85,1	88
Characteristics							
10	Terminal resistance	Ω	0,4	0,63	1,3	3,6	4,6
11	Terminal inductance	mH	0,043	0,087	0,18	0,32	0,51
12	Torque constant	mNm/A	14,95	18,69	28,96	42,71	48,1
13	Speed constant	rpm/V	633,3	506,7	327,1	222,2	197,9
14	Speed/torque gradient	rpm/mNm	17,1	17,1	14,8	18,8	18,9
15	Mechanical time constant	ms	6	6,56	5,75	6,92	6,94
16	Rotor inertia	gcm ²	33,54	36,66	37,14	35,08	35,08
Mechanical data							
17	Thermal resistance housing-ambient				4.9 K/W		
18	Thermal resistance winding-housing				2 K/W		
19	Thermal time constant winding				38 s		
20	Thermal time constant motor				780 s		
21	Ambient temperature				-20...+85°C		
22	Max. permissible winding temperature				+100°C		
23	Max. permissible speed				9500 rpm		
24	Max. axial load (dynamic)				9 N		
25	Max. force for press fits (static)				170 N		
26	Max. radial load, 5mm from flange				80 N		
Other specifications							
27	Number of poles				2		
28	Weight				290 gr		

Gearbox combinations

SVTG B 42



ATOM DC Series
SVTN B 01-4070 Graphite brushes

145 Watt

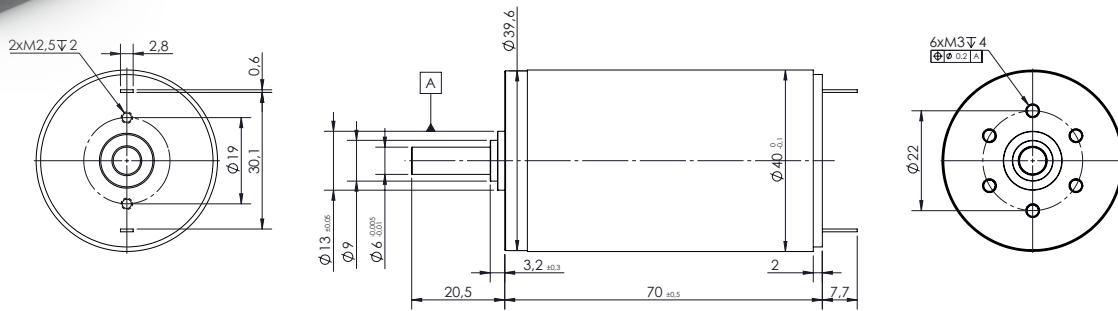
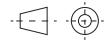

V 3

Values	Unit	SVTN B 01	4070-12..	4070-24..	4070-36..	4070-48..	4070-48..
Motor Data							
1	Nominal voltage	V	12	24	36	48	48
2	No-load speed	rpm	8200	7600	7500	7600	2200
3	No-load current	mA	500	180	180	100	18
4	Nominal speed	rpm	7585	7030	6900	6992	1606
5	Nominal torque	mNm	161,41	181,25	189,36	196,86	172,37
6	Nominal current	A	12,09	6,2	4,33	3,37	0,85
7	Stall torque	mNm	2152,1	2416,7	2367	2460,7	638,4
8	Stall current	A	155	80,5	52	41	3,1
9	Max. efficiency	%	89	90,8	88,6	90,4	85,3
Characteristics							
10	Terminal resistance	Ω	0,08	0,3	0,69	1,17	15,5
11	Terminal inductance	mH	0,016	0,083	0,18	0,34	4,08
12	Torque constant	mNm/A	13,93	30,09	45,68	60,16	207,1
13	Speed constant	rpm/V	683,3	316,7	208,3	158,3	45,8
14	Speed/torque gradient	rpm/mNm	3,8	3,1	3,2	3,1	3,4
15	Mechanical time constant	ms	5,6	4,42	4,3	4,05	4,31
16	Rotor inertia	gcm ²	140,23	134,1	137,14	125,21	119,52
Mechanical data							
17	Thermal resistance housing-ambient					4.7 K/W	
18	Thermal resistance winding-housing					1.9 K/W	
19	Thermal time constant winding					41.5 s	
20	Thermal time constant motor					809 s	
21	Ambient temperature					-20...+85°C	
22	Max. permissible winding temperature					+100°C	
23	Max. permissible speed					7600 rpm	
24	Max. axial load (dynamic)					9 N	
25	Max. force for press fits (static)					170 N	
26	Max. radial load, 5mm from flange					80 N	
Other specifications							
27	Number of poles					2	
28	Weight					485 gr	

Gearbox combinations

SVTG B 42

FLAT Series

SVTM F

Outrunner Brushless DC Motors

FLAT Series SVTM F

Outrunner Brushless DC Motors



Customizable



Compact



High torque



The natural geometry of the outrunner Brushless Flat Motors, as well as the iron core winding, are the perfect fit for applications requiring high-torque in reduced dimensions.

Simplified design, high-end material selection, and automated manufacturing make the Flat Motors a high-performance solution at a competitive price.

Our vocation in listening to the client's requirements has led us to develop a customization-minded offer, focusing on specific application requirements such as integrated feedbacks, special cables and the geometry of shafts and flanges.

Benefits

High power density

High torque

High efficiency

Cost-effective

Compact

Customizable

Product code

SVTM F ○○ - ◡◡◡◡ - ◊◊ - □ - △◡☆

□ Series

○ Diameter
 ø20mm [01]; ø32mm [02];
 ø45mm [03]; ø60mm [04];
 ø90mm [05]

◡ Nominal torque

◊ Nominal voltage

□ Shaft
 Single (standard) [S];
 Double [D]*

△ Connection
 Wires with connector (standard on SVTM F 04) or
 flexprint (standard on SVTM F 01, SVTM F 02) [W];
 PCB with connectors (standard on SVTM F 03, SVTM F 05) [C]

◡ Feedback
 Hall sensors (standard) [H];
 Integrated incremental encoder with Hall sensors [E]**

☆ Customization

** Only available for SVTM F 03-0.130, SVTM F 04 and SVTM F 05

Features

Winding	3 phases
Operating temperature	-20° +55° (other temperature ranges on request)
Insulation class	B, 130°C
Magnets	Neodymium
Design technology	Outer rotor

Feedback

Hall Sensor (standard)

Integrated incremental encoder (available on SVTM F 03, SVTM F 04, SVTM F 05)*

Customizations

Integrated feedback

Flange shape

Shaft

Connectors

Wires

* Please contact factory for more details

Table explanation

1 Nominal voltage

It is the applied voltage between two powered phases in block commutation. All nominal data (lines 2 – 9) refer to this voltage. Lower and higher voltages are permissible, provided that limits are not exceeded.

2 No load speed

It is the speed at which the unloaded motor runs with the nominal voltage applied. It is proportional to the applied voltage.

3 No load current

This is the typical current that the unloaded motor draws when operating at nominal voltage. No load friction depends heavily on temperature. It decreases in extended operation and increases at lower temperatures.

4 Nominal speed

It is the speed set for operation at nominal voltage and nominal torque at a motor temperature of 25°C.

5 Nominal torque

It is the torque generated for operation at nominal voltage and nominal current at a motor temperature of 25°C. It is at the limit of the motor's continuous operation range. Higher torques heat up the winding too much.

6 Nominal current

It is the current in the active phase the nominal torque at the given nominal speed (= max. permissible continuous load current). The maximum winding temperature is reached at 25°C ambient temperature in continuous operation with Nominal current.

6 Peak torque

7 Peak current

Stall torque is the linearly calculated load torque for motors that causes the shaft to stall at nominal voltage. This torque often cannot be achieved due to saturation effects.

Stall current is the quotient from nominal voltage and the motor's terminal resistance. Stall current is equivalent to stall torque. With larger motors, Stall current cannot be reached due to the amplifier's current limits.

8 Line to line resistance

It is determined by the resistance at 25 °C between two motor phase.

9 Line to line inductance

It is the winding inductance between two motor phase

10 Terminal inductance

It is the winding inductance between two motor phase.

11 Back EMF constant

It indicates the theoretical no load speed per volt of applied voltage, disregarding friction losses.

12 Speed constant

It indicates the theoretical no load speed per volt of applied voltage, disregarding friction losses.

13 Speed/torque gradient

The speed/torque gradient is an indicator of the motor's performance. It is based on the quotient of ideal no load speed and ideal stall torque (tolerance $\pm 20\%$).

14 Mechanical time constant

It is the time required for the rotor to accelerate from standstill to 63% of its no load speed.

15 Shaft radial play

Radial play is the bearing's radial movement.

16 Shaft axial play

Axial play is the bearing's axial movement. A spring is utilized to preload the motor's bearings.

17 Thermal resistance winding-housing

Characteristic values of thermal contact resistance without additional heat sinking. Lines 17 and 18 combined define the maximum heating at a given power loss (load). Thermal resistance R_{th2} on motors with metal flanges can decrease by up to 80% if the motor is coupled directly to a good heat-conducting.

18 Thermal time constant winding

These are the typical reaction times for a temperature change of winding and motor. It can be seen that the motor reacts much more sluggishly in thermal terms than the winding. The values are calculated from the product of thermal capacity and given heat resistances.

19 Operation ambient

Operating temperature range. This derives from the heat reliability of the materials.

20 Ambient temperature

Operating temperature range. This derives from the heat reliability of the materials.

21 Max. permissible winding temperature

Maximum permissible winding temperature.

22 Max. permissible speed

Is the maximum recommended speed based on thermal and mechanical perspectives. A reduced service life can be expected at higher speeds.

23 Radial play

Radial play is the bearing's radial movement

24 Max. axial load (dynamics)

Dynamic: axial loading permissible in operation. If different values apply for traction and thrust, the smaller value is given.

25 Max force for press fits (static)

Maximum axial force applying to the shaft at standstill if the force is not input at the other shaft end. This is not possible for motors with only one shaft end.

26 Max. radial load

The value is given for a typical distance from the front flange. As the distance increases, this value decreases.

27 Number of pole pairs

Number of north poles of the permanent magnet. The phase streams and commutation signals pass through per revolution p cycles. Servo-controllers require the correct details of the number of pole pairs.

28 Number of phases

All motors have three phases.

29 Weight



Flat Series
SVTM F 01

5 Watt

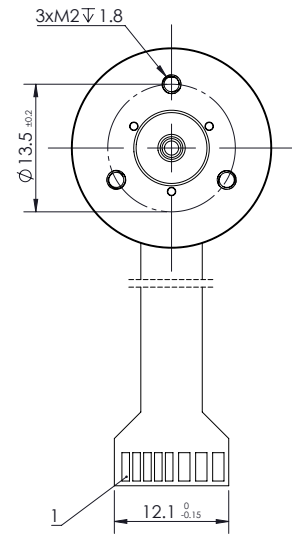
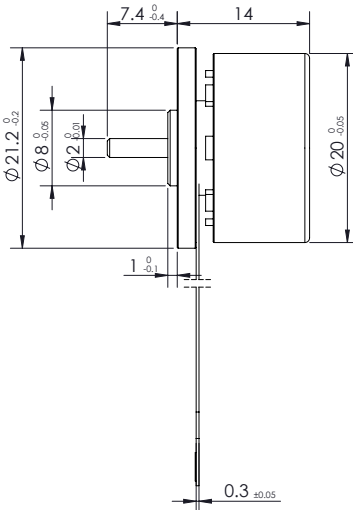
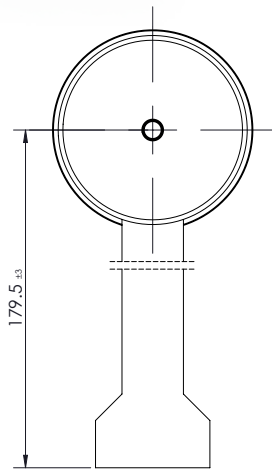

V 3

Flying leads

Mating: MOLEX 52207-1133

PIN1	Vhall (5-24 VDC)
PIN2	Hall sensor HC
PIN3	Hall sensor HA
PIN4	Hall sensor HB
PIN5	GND
PIN6	Motor winding MC
PIN7	Motor winding MB
PIN8	Motor winding MA

Drive combinations

E50 / E40 (Vout 90%) or E55 / E45 (Vout 100%)

Gearbox combinations

Please contact factory for more details

Values	Units	Tolerance	SVTM F 01 12 VDC	24 VDC
Motor data				
1	Nominal voltage	VDC	12	24
2	No load speed	rpm	±10% 9530	9530
3	No load current	mA	23	12
4	Nominal speed	rpm	±10% 5170	5220
5	Nominal torque	mNm	7.59	7.74
6	Nominal current	A	0.63	0.32
7	Peak torque	mNm	19	20
8	Peak current	A	±10% 1.62	0.85
Characteristics				
9	Line to line resistance	ohms@25°C	±10% 7.2	26.1
10	Line to line inductance	mH	±20% 0.62	2.6
11	Torque constant	mNm/A	±10% 12	24
12	Back EMF constant	Vrms/kRPM	±10% 0.89	1.78
13	Rotor inertia	g cm ²		5.1
Mechanical data (preloaded ball bearings)				
14	Max axial-force	N		4.8
15	Max radial-force*	N		14
16	Shaft radial play	mm @4N		0.02
17	Shaft axial play	mm @4N		0.14
Other specifications				
18	Number of poles	#		8
19	Weight	g		23
20	Operation ambient	°C	-20 +50 Humidity max 85% (no condensation)	

*@ 5mm from the flange



Flat Series
SVTM F 02

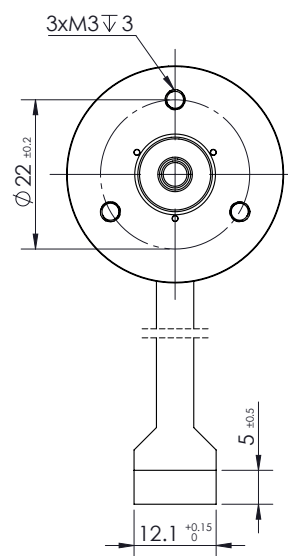
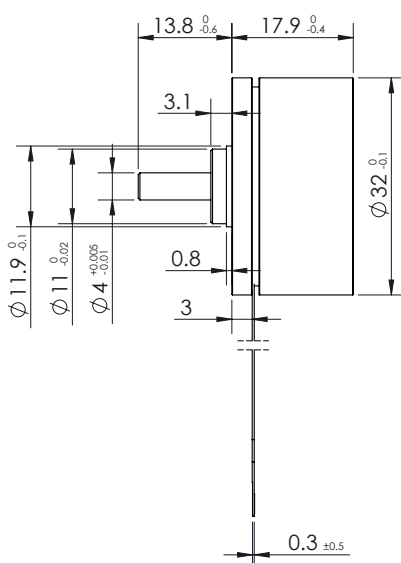
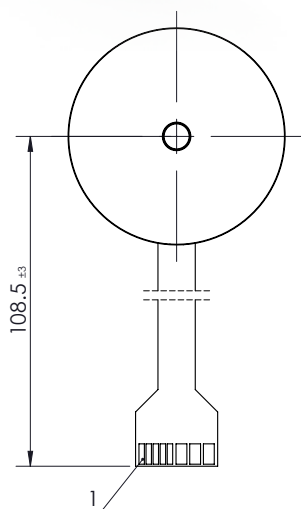

V 3

Flying leads

Mating: MOLEX 52207-1133

PIN1	Vhall (5-24 VDC)
PIN2	Hall sensor HC
PIN3	Hall sensor HA
PIN4	Hall sensor HB
PIN5	GND
PIN6	Motor winding MC
PIN7	Motor winding MB
PIN8	Motor winding MA

Drive combinations

E50 / E40 (Vout 90%) or E55 / E45 (Vout 100%)

Gearbox combinations

Please contact factory for more details

Values	Units	Tolerance	SVTM F 02				
			9 VDC	12 VDC	24 VDC	48 VDC	
Motor data							
1	Nominal voltage	VDC	9	12	24	48	
2	No load speed	rpm	±10%	3750	4650	4530	4800
3	No load current	mA		< 0.3	< 0.37	< 0.37	< 0.37
4	Nominal speed	rpm	±10%	2100	2800	2760	2950
5	Nominal torque	mNm		24.6	25.1	25.5	24.7
6	Nominal current	A		1.07	1	0.37	0.257
7	Peak torque	mNm		73.8	75.3	76.5	74.1
8	Peak current	A	±10%	3.2	3	1.59	0.97
Characteristics							
9	Line to line resistance	ohms@25°C	±10%	3.2	3.2	13.7	53
10	Line to line inductance	mH	±20%	1.20	1.21	4.86	27.8
11	Torque constant	mNm/A	±10%	23	24.67	48.2	96.1
12	Back EMF constant	Vrms/kRPM	±10%	1.7	1.8	3.57	7.1
13	Rotor inertia	g cm ²				35	
Mechanical data (preloaded ball bearings)							
14	Max axial-force	N			4.8		
15	Max radial-force*	N			14		
16	Shaft radial play	mm @4N			0.02		
17	Shaft axial play	mm @4N			0.14		
Other specifications							
18	Number of poles	#			8		
19	Weight	g			50		
20	Operation ambient	°C	-20 +50 Humidity max 85% (no condensation)				

*@ 5mm from the flange



Flat Series SVTM F 03

26 Watt

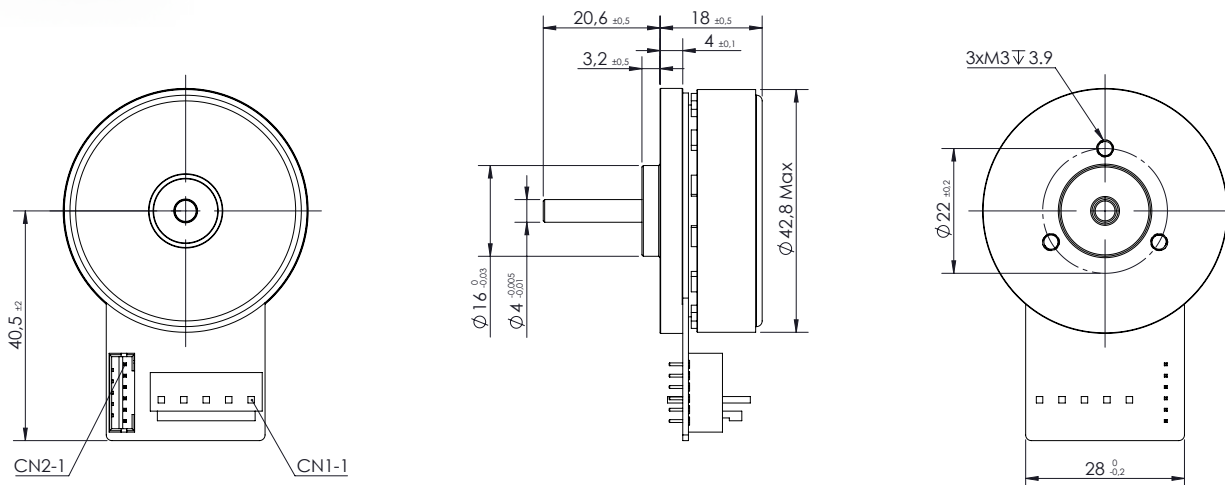

V 3

Connector 1		Connector 2	
JST B5P-VH		JST B6B-PH-K-S	
Mating: JST VHR-5N (power)		Mating: ST PHR-6 (feedback)	
PIN1	GND	PIN1	GND
PIN2	Motor winding MA	PIN2	Vhall (4.5-18VDC)
PIN3	Motor winding MB	PIN3	Hall sensor HC
PIN4	Motor winding MC	PIN4	Hall sensor HA
PIN5	GND	PIN5	Hall sensor HB
		PIN6	GND

Drive combinations
E50 / E40 (Vout 90%) or E55 / E45 (Vout 100%)

Gearbox combinations
Please contact factory for more details

Values	Units	Tolerance	SVTM F 03-0.050 24 VDC
Motor data			
1	Nominal voltage	VDC	24
2	No load speed	rpm	±10% 6500
3	No load current	mA	< 0.3
4	Nominal speed	rpm	±10% 5000
5	Nominal torque	mNm	50
6	Nominal current	A	1.58
7	Peak torque	mNm	150
8	Peak current	A	±10% 4.8
Characteristics			
9	Line to line resistance	ohms@25°C	±10% 1.47
10	Line to line inductance	mH	±20% 0.61
11	Torque constant	mNm/A	±10% 35.5
12	Back EMF constant	Vrms/kRPM	±10% 2.61
13	Rotor inertia	g cm ²	99
Mechanical data (preloaded ball bearings)			
14	Max axial-force	N	10
15	Max radial-force*	N	28
16	Shaft radial play	mm @4N	0.02
17	Shaft axial play	mm @4N	0.14
Other specifications			
18	Number of poles	#	16
19	Weight	g	80
20	Operation ambient	°C	-25 +55 Humidity max 85% (no condensation)

*@ 5mm from the flange



Flat Series
SVTM F 03

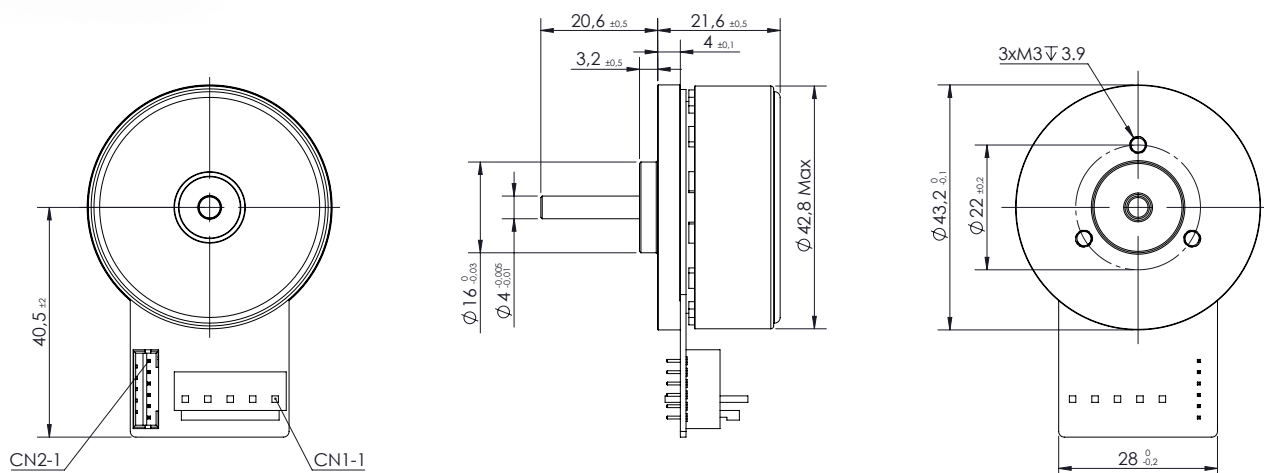

V 3

Connector 1		Connector 2	
JST B5P-VH		JST B6B-PH-K-S	
Mating: JST VHR-5N (power)		Mating: ST PHR-6 (feedback)	
PIN1	GND	PIN1	GND
PIN2	Motor winding MA	PIN2	Vhall (4.5-18VDC)
PIN3	Motor winding MB	PIN3	Hall sensor HA
PIN4	Motor winding MC	PIN4	Hall sensor HC
PIN5	GND	PIN5	Hall sensor HB
		PIN6	GND

Drive combinations
E50 / E40 (Vout 90%) or E55 / E45 (Vout 100%)
Gearbox combinations
Please contact factory for more details

Values	Units	Tolerance	SVTM F 03-0.084 24 VDC
Motor data			
1	Nominal voltage	VDC	24
2	No load speed	rpm	±10% 6700
3	No load current	mA	< 0.4
4	Nominal speed	rpm	±10% 5260
5	Nominal torque	mNm	84
6	Nominal current	A	2.36
7	Peak torque	mNm	250
8	Peak current	A	±10% 7
Characteristics			
9	Line to line resistance	ohms@25°C	±10% 0.7
10	Line to line inductance	mH	±20% 0.33
11	Torque constant	mNm/A	±10% 33.5
12	Back EMF constant	Vrms/kRPM	±10% 2.53
13	Rotor inertia	g cm ²	135
Mechanical data (preloaded ball bearings)			
14	Max axial-force	N	10
15	Max radial-force*	N	28
16	Shaft radial play	mm @4N	0.02
17	Shaft axial play	mm @4N	0.14
Other specifications			
18	Number of poles	#	16
19	Weight	g	120
20	Operation ambient	°C	-25 +55 Humidity max 85% (no condensation)

*@ 5mm from the flange



Flat Series SVTM F 03

66 Watt

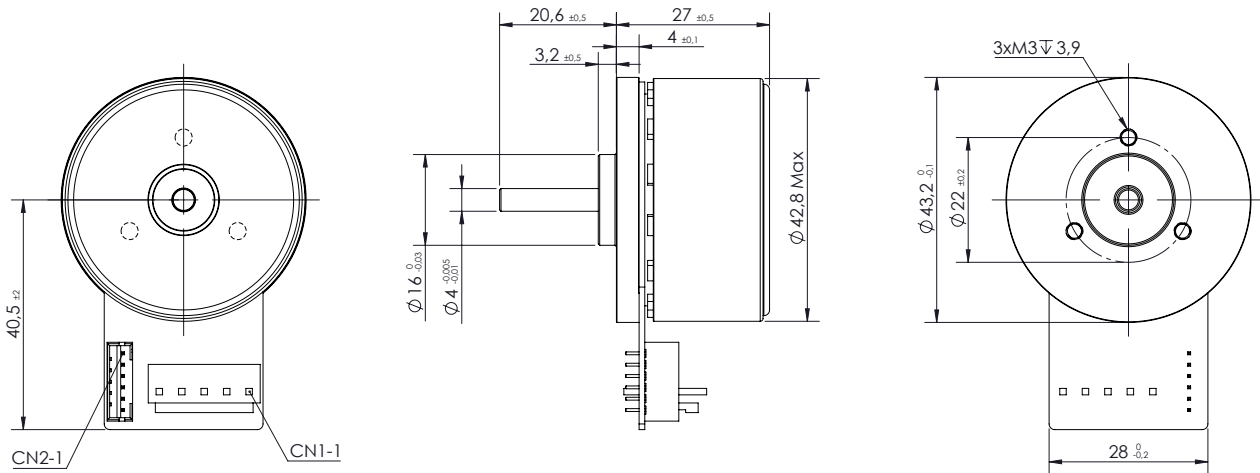

V 3

Connector 1		Connector 2	
JST B5P-VH		JST B6B-PH-K-S	
Mating: JST VHR-5N (power)		Mating: ST PHR-6 (feedback)	
PIN1	GND	PIN1	GND
PIN2	Motor winding MA	PIN2	Vhall (4.5-18VDC)
PIN3	Motor winding MB	PIN3	Hall sensor HA
PIN4	Motor winding MC	PIN4	Hall sensor HC
PIN5	GND	PIN5	Hall sensor HB
		PIN6	GND

Drive combinations	
E50 / E40 (Vout 90%) or E55 / E45 (Vout 100%)	
Optional encoder	
Integrated incremental encoder with Hall sensors	
Resolution	1024ppr, TTL
Channels	A,A/,B,B/
Length increase	+2mm
Please contact factory for more details	
Gearbox combinations	
Please contact factory for more details	

Values	Units	Tolerance	SVTM F 03-0130 24 VDC
Motor data			
1	Nominal voltage	VDC	24
2	No load speed	rpm	±10% 6100
3	No load current	mA	< 0.5
4	Nominal speed	rpm	±10% 4840
5	Nominal torque	mNm	130
6	Nominal current	A	3.26
7	Peak torque	mNm	390
8	Peak current	A	±10% 9.5
Characteristics			
9	Line to line resistance	ohms@25°C	±10% 0.56
10	Line to line inductance	mH	±20% 0.27
11	Torque constant	mNm/A	±10% 36.9
12	Back EMF constant	Vrms/kRPM	±10% 2.75
13	Rotor inertia	g cm ²	181
Mechanical data (preloaded ball bearings)			
14	Max axial-force	N	10
15	Max radial-force*	N	28
16	Shaft radial play	mm @4N	0.02
17	Shaft axial play	mm @4N	0.14
Other specifications			
18	Number of poles	#	16
19	Weight	g	150
20	Operation ambient	°C	-25 +55 Humidity max 85% (no condensation)

*@ 5mm from the flange

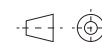

Flat Series
SVTM F 04

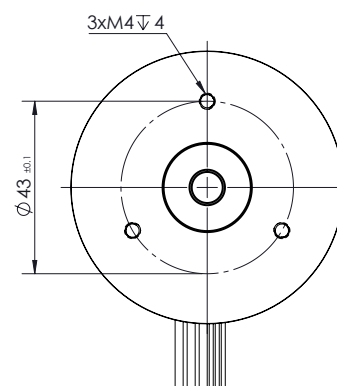
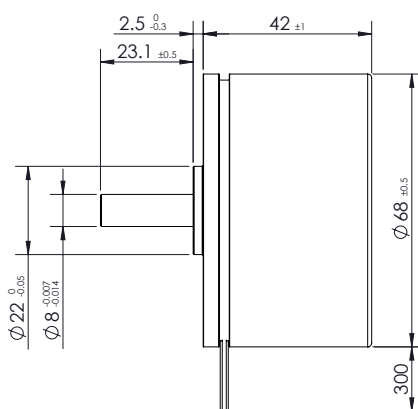
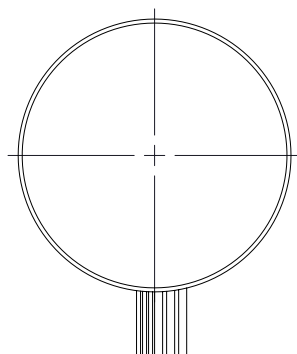

V 3

Flying leads		
AWG26	Red	Vhall (5 VDC)
AWG26	Green	Hall sensor HB
AWG26	Blue	Hall sensor HA
AWG26	White	Hall sensor HC
AWG26	Black	GND
AWG18	Yellow	Motor winding MA
AWG18	Red	Motor winding MB
AWG18	Black	Motor winding MC

Drive combinations	
E50 / E40 (Vout 90%) or E55 / E45 (Vout 100%)	
Optional encoder	
Integrated incremental encoder with Hall sensors	
Resolution	4096ppr, TTL
Channels	A,A/,B,B/,I,I/
Please contact factory for more details	
Gearbox combinations	
Please contact factory for more details	

Values	Units	Tolerance	SVTM F 04 24 VDC
Motor data			
1	Nominal voltage	VDC	24
2	No load speed	rpm	±10% 4400
3	No load current	mA	0.65
4	Nominal speed	rpm	±10% 3700
5	Nominal torque	mNm	290
6	Nominal current	A	5.6
7	Peak torque	mNm	870
8	Peak current	A	±10% 17
Characteristics			
9	Line to line resistance	ohms@25°C	±10% 0.25
10	Line to line inductance	mH	±20% 0.2
11	Torque constant	mNm/A	±10% 54
12	Back EMF constant	Vrms/kRPM	±10% 4.0
13	Rotor inertia	g cm ²	1000
Mechanical data (preloaded ball bearings)			
14	Max axial-force	N	10
15	Max radial-force*	N	28
16	Shaft radial play	mm @4N	0.02
17	Shaft axial play	mm @4N	0.08
Other specifications			
18	Number of poles	#	14
19	Weight	g	500
20	Operation ambient	°C	-25 +55 Humidity max 85% (no condensation)

*@ 10mm from the flange



Flat Series SVTM F 05

130 Watt

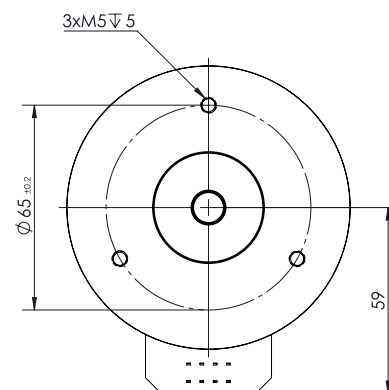
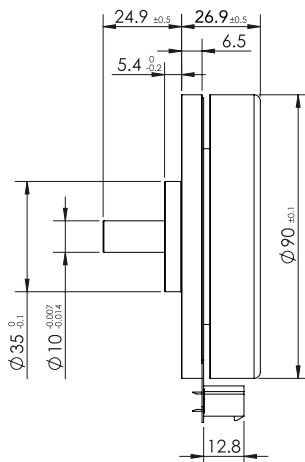
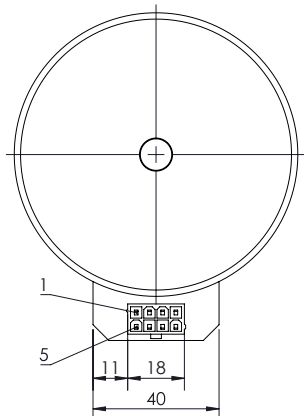

V 3

Connector

MOLEX 39-28-1083

Mating: Molex 039012080

PIN1	Hall sensor HA
PIN2	Hall sensor HB
PIN3	Vhall (5-24 VDC)
PIN4	Motor winding MC
PIN5	Hall sensor HC
PIN6	GND
PIN7	Motor winding MA
PIN8	Motor winding MB

Drive combinations

E50 / E40 (Vout 90%) or E55 / E45 (Vout 100%)

Gearbox combinations

Please contact factory for more details

Values	Units	Tolerance	SVTM F 05-0.457 24 VDC
Motor data			
1	Nominal voltage	VDC	24
2	No load speed	rpm	±10% 3300
3	No load current	mA	0.7
4	Nominal speed	rpm	±10% 2700
5	Nominal torque	mNm	457
6	Nominal current	A	6.8
7	Peak torque	mNm	1600
8	Peak current	A	±10% 23
Characteristics			
9	Line to line resistance	ohms@20°C	±10% 0.21
10	Line to line inductance	mH	±20% 0.19
11	Torque constant	mNm/A	±10% 63
12	Back EMF constant	Vrms/kRPM	±10% 5.2
13	Rotor inertia	g cm ²	3000
Mechanical data (preloaded ball bearings)			
14	Max axial-force	N	45
15	Max radial-force*	N	110
16	Shaft radial play	mm @4N	0.02
17	Shaft axial play	mm @4N	0.08
18	Length (L)	mm	26.9±05
Other specifications			
19	Number of poles	#	24.9
20	Weight	g	600
21	Operation ambient	°C	-25 +55 Humidity max 85% (no condensation)

*@ 10mm from the flange



Flat Series
SVTM F 05

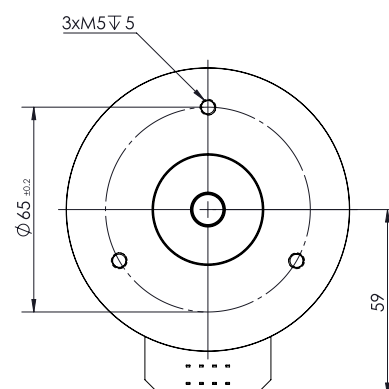
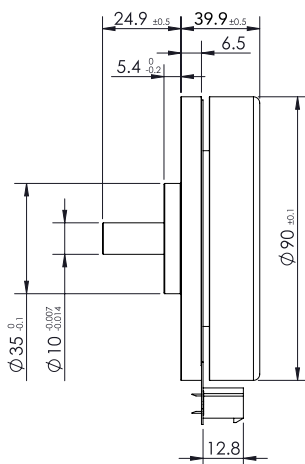
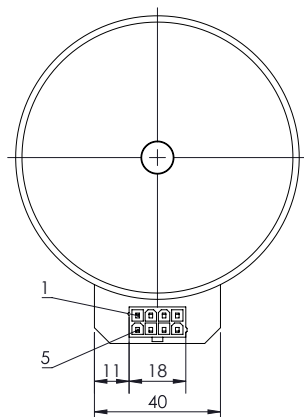

Connector	
MOLEX 39-28-1083	
Mating: Molex 039012080	
PIN1	Hall sensor HA
PIN2	Hall sensor HB
PIN3	Vhall (5-24 VDC)
PIN4	Motor winding MC
PIN5	Hall sensor HC
PIN6	GND
PIN7	Motor winding MA
PIN8	Motor winding MB

Drive combinations	
E50 / E40 (Vout 90%) or E55 / E45 (Vout 100%)	
Optional encoder	
Integrated incremental encoder with Hall sensors	
Resolution	4096ppr, TTL
Channels	A,A/,B,B/,I,I/
Length increase	+2mm
Please contact factory for more details	
Gearbox combinations	
Please contact factory for more details	

Values	Units	Tolerance	SVTM F 05-0.964 48 VDC
Motor data			
1	Nominal voltage	VDC	48
2	No load speed	rpm	±10% 1900
3	No load current	mA	0.35
4	Nominal speed	rpm	±10% 1670
5	Nominal torque	mNm	964
6	Nominal current	A	4.3
7	Peak torque	mNm	3000
8	Peak current	A	±10% 13
Characteristics			
9	Line to line resistance	ohms@20°C	±10% 0.6
10	Line to line inductance	mH	±20% 0.7
11	Torque constant	mNm/A	±10% 241
12	Back EMF constant	Vrms/kRPM	±10% 17.9
13	Rotor inertia	g cm ²	5000
Mechanical data (preloaded ball bearings)			
14	Max axial-force	N	45
15	Max radial-force*	N	110
16	Shaft radial play	mm @4N	0.02
17	Shaft axial play	mm @4N	0.08
18	Length (L)	mm	39.9±05
Other specifications			
19	Number of poles	#	39.9
20	Weight	g	1000
21	Operation ambient	°C	-25 +55 Humidity max 85% (no condensation)

*@ 10mm from the flange

COSMOS SVTG

Planetary gearboxes

COSMOS SVTG

Planetary gearboxes



Cost effective



Robust



Compact



The planetary gearboxes are characterized by a robust design and are employed for uses where high-performance and reduce dimensions are required.

The gear trains can be made of steel or plastic polymers, also in blended configurations when needed.

The gearboxes are lubricated according to the needs with reference to temperature and functionality. They are available with sleeve, ball or customized bearings.

Available also in personalized options designed upon request.

Features

Gear materials	Metal / Polymer
Diameter	from 10mm to 42mm
Torque	from 0.2Nm to 45Nm
Operating temperature	-20° +100°C (special lubrication might be needed)
Estimated operating lifetime	Lifetime depends on gearbox working conditions. Operating life span can vary between 1.000 to 3.000 work hours.

Product code

SVTG ◊ ○○ - ◇ - □□□□□ - ◊△△

◊ Bearings
Sleeve [A]; Ball [B]

○ Diameter

◇ Number of gear stages

□ Ratio

◊ Type of motor
Brushless [A]; Brushed [B]; Flat [F]

△ Motor diameter

Benefits

Robust

Compact

Cost-effective

Low Noise

Customizations

Flange

Shaft

Input-stage geartrain

Shape

Length/Diameter/D-Cut/...

Polymer (for quiet operation)

Table explanation

1 Housing material

2 Geartrain material

Geartrain could be in metal and polymer to increase torque performance and reduce noise.

3 Max input speed (continuous operation)

It is based on service life considerations. If this value is greatly exceeded, the service life can be shortened, the gear heats up more and more noise is generated.

4 Bearing on output shaft

It is possible to choose a ball bearing or sleeve bearing depending on the application, as standard from size 22 is available only for ball bearings.

5 Max radial load (dynamics)

The value is given for a typical distance from the front flange. As the distance increases, this value decreases.

6 Max. axial load

Dynamic: axial loading permissible in operation. If different values apply for traction and thrust, the smaller value is given.

7 Max shaft press fit force

Maximum axial force applying to the shaft at standstill if the force is not input at the other shaft end. This is not possible for motors with only one shaft end.

8 Radial play

The radial measurement is always carried out under a test force that is smaller than the maximum radial load.

9 Axial play

The value for the axial play of a gear is determined between the two axial end positions of the output shaft.

10 Temperature range

The temperature range is -20°C and $+125^{\circ}\text{C}$, but may be extended for some gears. Special lubrication can be supplied on request, even for other temperature ranges.

11 Number of stages

It states the number of gear stages engaged in series.

12 Reduction ratio

The reduction indicates the ratio by which the speed of the gear output shaft is smaller than the motor speed.

13 Gear length L [mm]

L describes the gearbox length (adapter flange included).

14 Continuous torque [Nm]

The continuous torque provides the maximum load permanently delivered to the output shaft. It can be exceeded, but it affects the service life.

15 Intermittent torque [Nm]

The short-time torque is the maximum torque that may be output on the output shaft.

16 Efficiency [%]

The specified efficiency is a maximum value that is valid for maximum continuous torque. The efficiency is stage-dependent and is related to the output torque and operating temperature.

17 No load backlash [°]

Gear backlash is the turning angle of the gear output shaft when the input shaft is blocked.

18 Weight [g]

Table explanation

1 Housing material

2 Geartrain material

Geartrain could be in metal and polymer to increase torque performance and reduce noise.

3 Max input speed (continous operation)

It is based on service life considerations. If this value is greatly exceeded, the service life can be shortened, the gear heats up more and more noise is generated.

4 Bearing on output shaft

It is possible to choose a ball bearing or sleeve bearing depending on the application, as standard from size 22 is available only for ball bearings.

5 Max radial load (dynamics)

The value is given for a typical distance from the front flange. As the distance increases, this value decreases.

6 Max. axial load

Dynamic: axial loading permissible in operation. If different values apply for traction and thrust, the smaller value is given.

7 Max shaft press fit force

Maximum axial force applying to the shaft at standstill if the force is not input at the other shaft end. This is not possible for motors with only one shaft end.

8 Radial play

The radial measurement is always carried out under a test force that is smaller than the maximum radial load.

9 Axial play

The value for the axial play of a gear is determined between the two axial end positions of the output shaft.

10 Temperature range

The temperature range is -20°C and $+125^{\circ}\text{C}$, but may be extended for some gears. Special lubrication can be supplied on request, even for other temperature ranges.

11 Number of stages

It states the number of gear stages engaged in series.

12 Reduction ratio

The reduction indicates the ratio by which the speed of the gear output shaft is smaller than the motor speed.

13 Gear length L [mm]

L describes the gearbox length (adapter flange included).

14 Continuous torque [Nm]

The continuous torque provides the maximum load permanently delivered to the output shaft. It can be exceeded, but it affects the service life.

15 Intermittent torque [Nm]

The short-time torque is the maximum torque that may be output on the output shaft.

16 Efficiency [%]

The specified efficiency is a maximum value that is valid for maximum continuous torque. The efficiency is stage-dependent and is related to the output torque and operating temperature.

17 No load backlash [°]

Gear backlash is the turning angle of the gear output shaft when the input shaft is blocked.

18 Weight [g]



COSMOS Series SVTG A 10

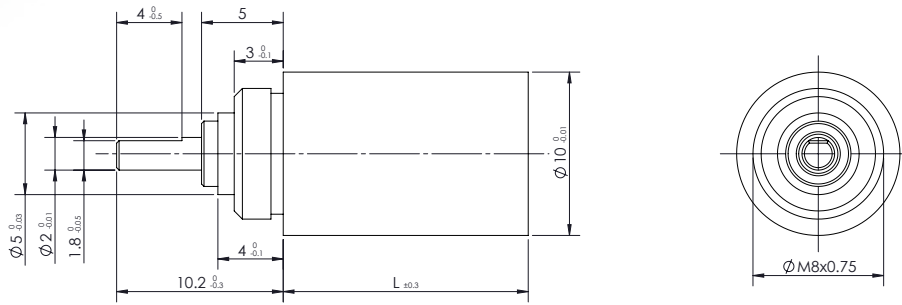
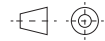

V 3

A 10							
Values	Unit						
1	Housing material		Metal				
2	Geartrain material		Metal/Polymer				
3	Max input speed (continuous operation)	rpm	≤ 20.000				
4	Bearings on output shaft		Sleeve bearings				
Max shaft load							
5	Radial (5mm from mounting face)	N	≤ 10				
6	Axial	N	≤ 8				
7	Max shaft press fit force	N	≤ 10				
Shaft play							
8	Radial	mm	≤ 0.1				
9	Axial	mm	≤ 0.2				
10	Operating temperature range	°C	-20 +125				
11	Number of gear stages		1	2	3	4	5
12	Reduction ratio		4:1	16:1	64:1	256:1	1024:1
13	Gearhead Length L	mm	11	13.8	16.6	19.4	22.2
14	Continuous torque	Nm	0.01	0.025	0.1	0.15	0.15
15	Intermittent torque	Nm	0.02	0.05	0.15	0.2	0.2
16	Max Efficiency	%	90	81	73	65	59
17	No-Load Backlash	°	1	1.2	1.2	1.5	1.5
18	Weight	g	5	6.3	7.5	8.8	10

Motor combinations

SVTN A - Brushless

SVTN A 01-1220*

SVTN A 01-1230*

SVTN A 03-1228*

SVTN B - Brushed

SVTN B 01-1219*

SVTN B 01-1331*

*On request



COSMOS Series
SVTG A 12

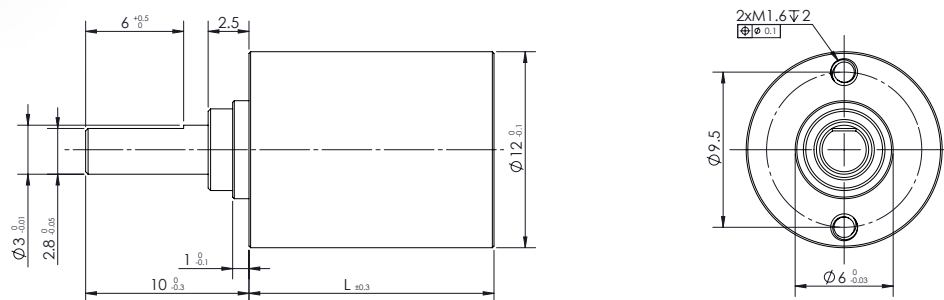

V 3

A 12							
Values	Unit						
1	Housing material	Metal					
2	Geartrain material	Metal/Polymer					
3	Max input speed (continuous operation)	rpm	≤ 20.000				
4	Bearings on output shaft	Sleeve bearings/Ball bearings**					
Max shaft load							
5	Radial (5mm from mounting face)	N	≤ 10				
6	Axial	N	≤ 8				
7	Max shaft press fit force	N	≤ 10				
Shaft play							
8	Radial	mm	≤ 0.1				
9	Axial	mm	≤ 0.2				
10	Operating temperature range	°C	-20 +125				
11	Number of gear stages		1	2	3	4	5
12	Reduction ratio		3.9:1	14:1	42:1	146:1	650:1
			4.6:1	16:1	54:1	187:1	946:1
				18:1	61:1	282:1	1345:1
				21:1	72:1	342:1	1661:1
					84:1	387:1	2094:1
				98:1	454:1	2586:1	
					560:1	3194:1	
13	Gearhead Length L	mm	13,3	16,1	18,9	21,7	24,5
14	Continuous torque	Nm	0,2	0,2	0,3	0,3	0,35
15	Intermittent torque	Nm	0,3	0,3	0,45	0,45	0,5
16	Max Efficiency	%	90	81	73	65	59
17	No-Load Backlash	°	1	1.2	1.2	1.5	1.5
18	Weight	g	7	10	13	16,5	20

Motor combinations

SVTN A - Brushless

SVTN A 01-1220*

SVTN A 01-1230*

SVTN A 03-1228*

SVTN B - Brushed

SVTN B 01-1219*

SVTN B 01-1331*

*On request

**Optional



COSMOS Series SVTG A 16

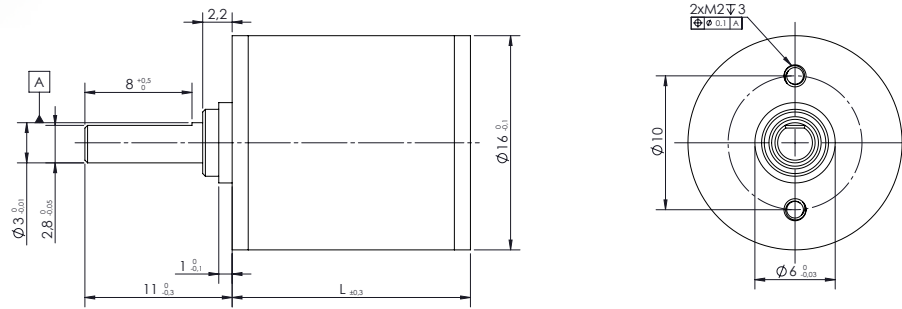
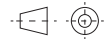

V 3

A 16							
Values	Unit						
1	Housing material	Metal					
2	Geartrain material	Metal/Polymer					
3	Max input speed (continuous operation)	rpm	≤ 20.000				
4	Bearings on output shaft	Sleeve bearings/Ball bearings*					
Max shaft load							
5	Radial (5mm from mounting face)	N	≤ 10				
6	Axial	N	≤ 8				
7	Max shaft press fit force	N	≤ 10				
Shaft play							
8	Radial	mm	≤ 0.1				
9	Axial	mm	≤ 0.2				
10	Operating temperature range	$^{\circ}\text{C}$	$-20 +125$				
11	Number of gear stages		1	2	3	4	5
12	Reduction ratio		3.8:1	14:1	54:1	206:1	1012:1
			4.3:1	16:1	70:1	267:1	1152:1
			5.1:1	18:1	80:1	304:1	1311:1
				22:1	94:1	407:1	1492:1
					111:1	479:1	1596:1
					131:1	664:1	2067:1
							2434:1
13	Gearhead Length L	mm	17.8	21.4	25	28.6	32.2
14	Continuous torque	Nm	0.2	0.2	0.3	0.3	0.35
15	Intermittent torque	Nm	0.3	0.3	0.45	0.45	0.5
16	Max Efficiency	%	90	81	73	65	59
17	No-Load Backlash	$^{\circ}$	1	1.5	1.5	2	2
18	Weight	g	15	20	25	30	35

Motor combinations

SVTN A - Brushless

SVTN A 01-1630

SVTN A 01-1636

SVTN A 03-1638

SVTN B - Brushed

SVTN B 01-1524

SVTN B 01-1640

SVTN B 01-1725

SVTN B 01-1740

*Optional



COSMOS Series
SVTG B 22

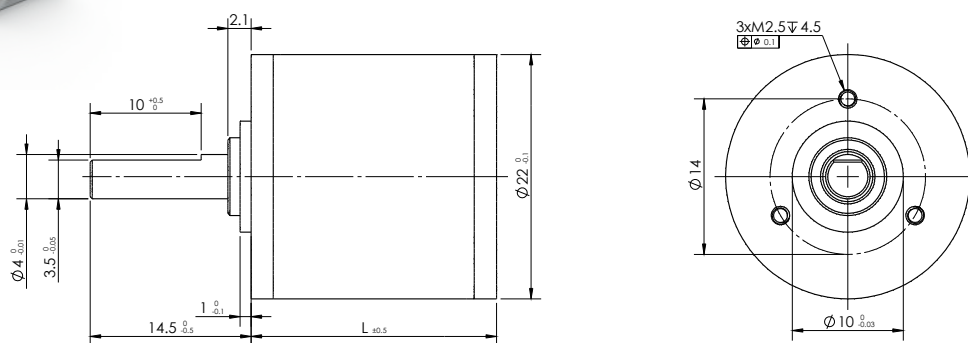
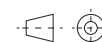

V 3

B 22											
Values	Unit										
1 Housing material	Metal										
2 Geartrain material	Metal/Polymer										
3 Max input speed (continuous operation)	rpm	≤ 10.000									
4 Bearings on output shaft	Ball bearings										
Max shaft load											
5 Radial (5mm from mounting face)	N	≤ 50									
6 Axial	N	≤ 50									
7 Max shaft press fit force	N	≤ 100									
Shaft play											
8 Radial	mm	≤ 0.1									
9 Axial	mm	≤ 0.2									
10 Operating temperature range	$^{\circ}\text{C}$	$-20 +125$									
11 Number of gear stages		1	2	3	4	5					
12 Reduction ratio		3.6:1	5.5:1	13:1	22:1	46:1	101:1	182:1	405:1	729:1	1936:1
		4.0:1		14:1		51:1	121:1	204:1	466:1	816:1	2286:1
				16:1		59:1		263:1	557:1	1024:1	2662:1
				18:1		64:1		302:1		1209:1	
					74:1		339:1		1557:1		
					85:1						
13 Gearhead Lenght L	mm	22.1	28.5	27.6	32.6	31.4	36.4	35.2	40.2	39	44
14 Continuous torque	Nm	0.3		0.3		0.5		0.5		0.75	
15 Intermittent torque	Nm	0.5		0.5		0.8		0.8		1	
16 Max Efficiency	%	90		81		73		65		59	
17 No-Load Backlash	$^{\circ}$	1		1.5		1.5		2		2	
18 Weight	g	30		35		46		55		65	

Motor combinations

SVTN A - Brushless

- SVTN A 01-2040
- SVTN A 01-2232
- SVTN A 01-2240
- SVTN A 01-2248
- SVTN A 01-2260
- SVTN A 03-2238
- SVTN A 03-2246

SVTN B - Brushed

- SVTN B 01-2225
- SVTN B 01-2230

*Optional



COSMOS Series SVTG B 24

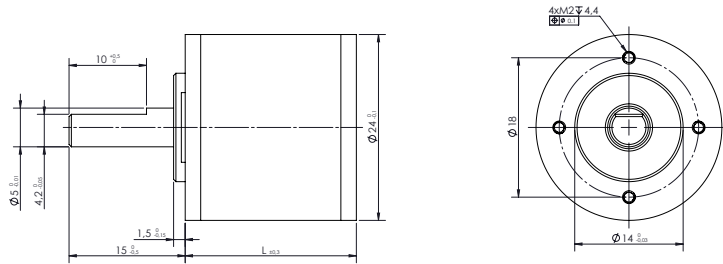
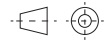

V 3

B 24											
Values	Unit										
1	Housing material	Metal									
2	Geartrain material	Metal/Polymer									
3	Max input speed (continuous operation)	rpm	≤ 10.000								
4	Bearings on output shaft	Ball bearings									
Max shaft load											
5	Radial (5mm from mounting face)	N	≤ 50								
6	Axial	N	≤ 50								
7	Max shaft press fit force	N	≤ 100								
Shaft play											
8	Radial	mm	≤ 0.1								
9	Axial	mm	≤ 0.2								
10	Operating temperature range	°C	-20 +125								
11	Number of gear stages		1	2	3	4	5				
12	Reduction ratio		3.3:1	12:1	17:1	36:1	56:1	119:1	408:1	660:1	1036:1
			4.3:1	14:1	22:1	47:1	95:1	154:1	493:1	741:1	1346:1
						61:1		200:1		857:1	1628:1
						79:1		260:1			1748:1
							337:1			2114:1	
13	Gearhead Length L	mm	22.1	26.2	30.8	32	36.6	36.1	40.7	40.2	44.8
14	Continuous torque	Nm	0.5	0.8		1.5		1.8		2.5	
15	Intermittent torque	Nm	1	1.5		2		2.5		3.5	
16	Max Efficiency	%	90	81		73		65		59	
17	No-Load Backlash	°	1	1.5		1.5		2		2	
18	Weight	g	35	41		52		59		68	

Motor combinations

SVTN A - Brushless

SVTN A 01-2232
 SVTN A 01-2240
 SVTN A 01-2248
 SVTN A 01-2260
 SVTN A 01-2446
 SVTN A 01-2453
 SVTN A 03-2238
 SVTN A 03-2246
 SVTN A 03-2452
 SVTN A 03-2459

SVTN B - Brushed

SVTN B 01-2225
 SVTN B 01-2230



COSMOS Series
SVTG B 28

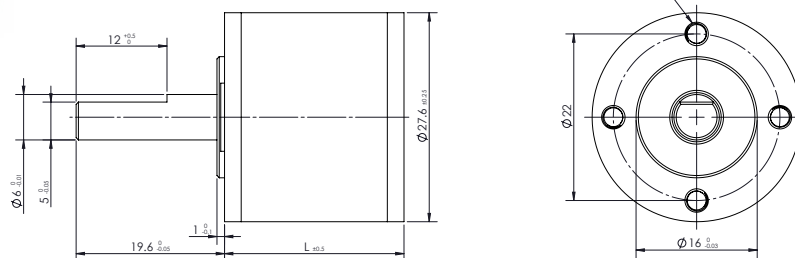

V 3

B 28											
Values	Unit										
1	Housing material	Metal									
2	Geartrain material	Metal/Polymer									
3	Max input speed (continuous operation)	rpm	≤ 10.000								
4	Bearings on output shaft	Ball bearings									
Max shaft load											
5	Radial (5mm from mounting face)	N	≤ 50								
6	Axial	N	≤ 50								
7	Max shaft press fit force	N	≤ 100								
Shaft play											
8	Radial	mm	≤ 0.1								
9	Axial	mm	≤ 0.2								
10	Operating temperature range	°C	-20 +125								
11	Number of gear stages		1	2	3	4	5				
12a	Reduction ratio ("A" combination)		3.6:1	5.5:1	16:1	46:1	101:1	182:1	405:1	729:1	1936:1
			4.0:1		18:1	51:1	121:1	204:1	466:1	816:1	2286:1
					21:1	59:1		263:1	557:1	1024:1	2662:1
						64:1		302:1		1209:1	
						74:1		339:1		1557:1	
13a	Gearhead Lenght L ("A" combination)	mm	28.7	34.2	33.2	37.7	44.2	42.2	48.7	46.7	53.2
12b	Reduction ratio ("B" combination)		3.6:1		16:1	46:1		182:1		729:1	
			4.0:1		18:1	51:1		204:1		816:1	
			5.5:1		21:1	59:1		263:1		1024:1	
						64:1		302:1		1209:1	
						74:1		339:1		1557:1	
13b	Gearhead Lenght L ("B" combination)	mm		23.7	29.2	33.7	44.2	42.2	48.7	46.7	53.2
12c	Reduction ratio ("C" combination)		3.6:1	4.0:1	16:1	46:1		182:1		729:1	
				5.5:1	18:1	51:1		204:1		816:1	
					21:1	59:1		263:1		1024:1	
						64:1		302:1		1209:1	
						74:1		339:1		1557:1	
13c	Gearhead Lenght L ("C" combination)	mm	28.7	34.2	38.7	43.2	44.2	42.2	48.7	46.7	53.2
14	Continuous torque	Nm	0.5		1	3		3		3	
15	Intermittent torque	Nm	0.8		2	4		4		4	
16	Max Efficiency	%	90		81	73		65		59	
17	No-Load Backlash	°	1		1.2	1.2		1.5		1.5	
18	Weight	g	50		65	85		95		110	

Motor combinations "A"

- | | |
|---------------------------|-------------------------|
| SVTN A - Brushless | SVTN B - Brushed |
| SVTN A 01-2845 | SVTN B 01-2864 |
| SVTN A 01-2854 | |
| SVTN A 01-2864 | |
| SVTN A 03-2854 | |
| SVTN A 03-2863 | |

Motor combinations "B"

- | | |
|---------------------------|-------------------------|
| SVTN A - Brushless | SVTN B - Brushed |
| SVTN A 01-2446 | SVTN B 01-2642 |
| SVTN A 01-2453 | |
| SVTN A 03-2452 | |
| SVTN A 03-2459 | |

Motor combinations "C"

- | |
|---------------------------|
| SVTN A - Brushless |
| SVTN A 01-3242 |
| SVTN A 01-3260 |
| SVTN A 01-3270 |
| SVTN A 03-3270 |



COSMOS Series SVTG B 32

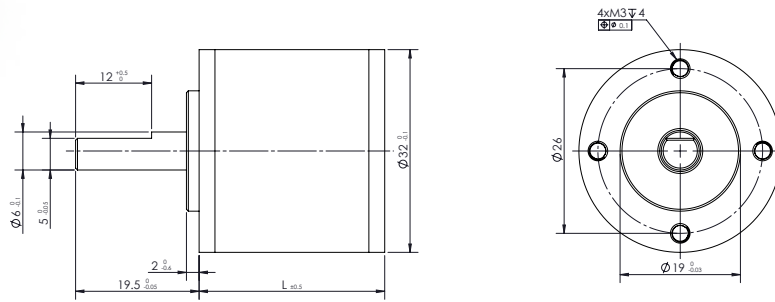
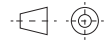

V 3

B 32													
Values	Unit												
1	Housing material	Metal											
2	Geartrain material	Metal/Polymer											
3	Max input speed (continuous operation) rpm	≤ 10,000											
4	Bearings on output shaft	Ball bearings											
Max shaft load													
5	Radial (5mm from mounting face)	N	≤ 100										
6	Axial	N	≤ 80										
7	Max shaft press fit force	N	≤ 120										
Shaft play													
8	Radial	mm	≤ 0.1										
9	Axial	mm	≤ 0.2										
10	Operating temperature range	°C	-20 +125										
11	Number of gear stages	1		2		3		4		5			
12a	Reduction ratio ("A" combination)	3.1:1	4.8:1	10:1	15:1	30:1	46:1	159:1	223:1	412:1	694:1	2548:1	
		4.0:1			19:1	51:1	62:1	178:1	266:1		765:1	3174:1	
					23:1		72:1		298:1		856:1		
							80:1		344:1		989:1		
							92:1				1429:1		
							111:1				1836:1		
13a	Gearhead Length L ("A" combination)	mm	29.3	38.8	38.1	42.6	44.4	48.9	50.7	55.2	57.2	61.5	63.5
12b	Reduction ratio ("B" combination)		3.1:1	5.7:1	10:1	23:1	30:1	159:1		412:1	694:1	3174:1	
			4.0:1		15:1		46:1	178:1			765:1		
			4.8:1		19:1		51:1	223:1			856:1		
							62:1	266:1			989:1		
							72:1	298:1			1429:1		
							80:1	344:1			1846:1		
							92:1				2548:1		
							111:1						
13b	Gearhead Length L ("B" combination)		29.3	38.8	38.1	44.6	44.4	50.7		57.2	57	63.5	
14	Continuous torque	Nm	1	1.5		2.5		3			5		
15	Intermittent torque	Nm	2	3		5		6			7.5		
16	Max Efficiency	%	90	81		73		65			59		
17	No-Load Backlash	°	1	1.5		1.5		2			2		
18	Weight	g	125	147		169		191			213		

Motor combinations "A"

SVTN A - Brushless

SVTN A 01-3242
SVTN A 01-3260
SVTN A 01-3270
SVTN A 03-3270

Motor combinations "B"

SVTN A - Brushless

SVTN A 01-2845
SVTN A 01-2854
SVTN A 01-2864
SVTN A 03-2854
SVTN A 03-2863

SVTN B - Brushed

SVTN B 01-2864



COSMOS Series
SVTG B 36

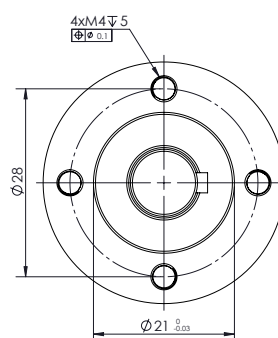
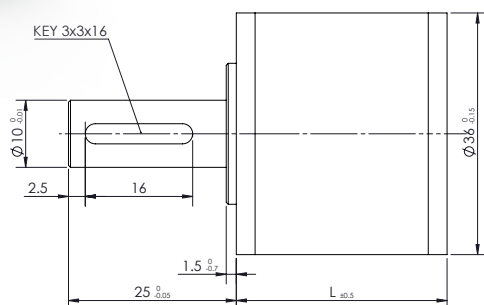

V 3

B 36												
Values	Unit											
1	Housing material	Metal										
2	Geartrain material	Metal/Polymer										
3	Max input speed (continuous operation)	rpm	≤ 10.000									
4	Bearings on output shaft	Ball bearings										
Max shaft load												
5	Radial (5mm from mounting face)	N	≤ 100									
6	Axial	N	≤ 80									
7	Max shaft press fit force	N	≤ 120									
Shaft play												
8	Radial	mm	≤ 0.1									
9	Axial	mm	≤ 0.2									
10	Operating temperature range	°C	-20 +125									
11	Number of gear stages		1		2		3		4		5	
12	Reduction ratio		3.7:1	6.5:1	14:1	30:1	53:1	142:1	198:1	661:1	1285:1	
			4.7:1		17:1		66:1	169:1	246:1	920:1	3083:1	
					22:1		82:1	197:1	306:1		4294:1	
							102:1	241:1	381:1		5981:1	
								275:1	474:1			
13	Gearhead Length L	mm	31.4	39.4	42.7	50.7	50	58	57.3	65.3	64.6	72.6
14	Continuous torque	Nm	4		8		16		16		20	
15	Intermittent torque	Nm	5		12		25		25		30	
16	Max Efficiency	%	90		81		73		65		59	
17	No-Load Backlash	°	0.8		1		1		1.2		1.2	
18	Weight	g	210		245		280		315		350	

Motor combinations

SVTN A - Brushless

- SVTN A 01-3242
- SVTN A 01-3260
- SVTN A 01-3270
- SVTN A 01-3660
- SVTN A 01-3670
- SVTN A 03-3270
- SVTN A 03-3673
- SVTN A 03-3683

SVTN B - Brushed

- SVTN B 01-3571



COSMOS Series SVTG B 42

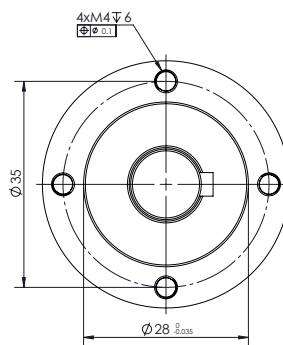
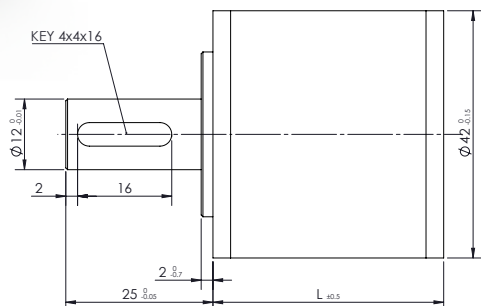

V 3

B 42											
Values	Unit										
1	Housing material	Metal									
2	Geartrain material	Metal/Polymer									
3	Max input speed (continuous operation)	rpm	≤ 10.000								
4	Bearings on output shaft	Ball bearings									
Max shaft load											
5	Radial (5mm from mounting face)	N	≤ 200								
6	Axial	N	≤ 100								
7	Max shaft press fit force	N	≤ 120								
Shaft play											
8	Radial	mm	≤ 0.1								
9	Axial	mm	≤ 0.2								
10	Operating temperature range	°C	-20 +125								
11	Number of gear stages		1	2	3	4	5				
12a	Reduction ratio ("A" combination)		3.1:1	5.7:1	10:1	43:1	115:1	168:1	574:1	807:1	1834:1
			4.2:1		12:1	54:1	159:1	225:1	661:1	1080:1	2300:1
					15:1	72:1		301:1	762:1	1434:1	3301:1
					20:1	83:1		400:1			4060:1
						96:1		461:1			5247:1
12b	Gearhead Length L ("A" combination)	mm	39.2	41.7	51.2	60.2	62.7	75.2	77.7	84.2	86.7
13a	Reduction ratio ("B" combination)		3.1:1	5.7:1	10:1	43:1	115:1	168:1	574:1	806.5:1	1834:1
			4.2:1		12:1	54:1	159:1	225:1	661:1	1080:1	2300:1
					15:1	72:1		301:1	762:1	1434:1	3301:1
					20:1	83:1		400:1			4060:1
						96:1		461:1			5247:1
13b	Gearhead Length L ("B" combination)	mm	34.2	39.2	46.2	55.2	60.2	70.2	75.2	79.2	84.2
18	Continuous torque	Nm	3		12	16		25		25	
19	Intermittent torque	Nm	5		20	25		36		36	
20	Max Efficiency	%	90		81	73		65		59	
21	No-Load Backlash	°	0.8		1	1		1.2		1.2	
22	Weight	g	250		345	405		490		580	

Motor combinations "A"

SVTN A - Brushless

SVTN A 01-4058
SVTN A 01-4070
SVTN A 01-4088

SVTN B - Brushed

SVTN B 01-4050
SVTN B 01-4070

Motor combinations "B"

SVTN A - Brushless

SVTN A 01-3660
SVTN A 01-3670
SVTN A 03-3673
SVTN A 03-3683

SVTN B - Brushed

SVTN B 01 3571

ACCESSORIES

Contents

Encoders	p. 118-119
Drives	p. 120-139
PCB Board & Cables	p. 140-141

Encoders

Magnetic Incremental Encoders



Cost effective



Robust



Compact



Thanks to incremental magnetic encoders (single ended and line driver), you can obtain a reliable control of speed and position.

*As an option, incremental optic encoders are available for high resolution needs.

Features

Housing	Engineering plastic
Operating temperature	-40° +125° C
Signal	3 or 5 channels: A/B; A A/, B B/, I I/
Resolution	from 25 to 1024 ppr
Supply Voltage	5 VDC
Max speed	28.000 rpm

EN 16A,
EN 16AL

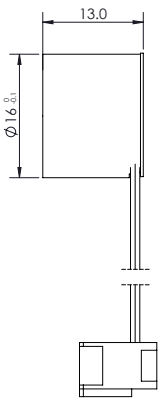

EN 22A, EN 22AL
EN 22B, EN 22BL

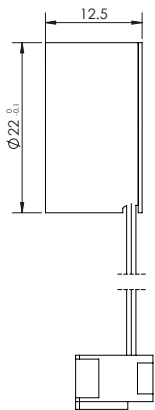

EN 24B,
EN 24BL

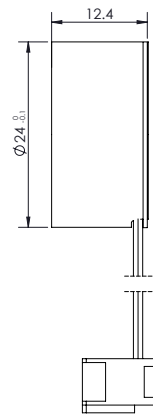

Electric Data	Unit	EN Series	EN ..L Series
1 Output signal		TTL single ended	TTL line driver
2 Number of channels	#	3	5
3 Supply voltage	VDC	5	5
4 Counts per revolution	ppr		up to 1024
5 Max. speed	rpm	28000	28000
6 Phase shift, Channel A to B	deg.		90
7 Index pulse width	deg.		90
8 Inertia of code disc	g/cm ²		0,7
9 Operating temperature range	°C		-40..+125

Features & Configuration

- Magnetic rotary encoder chip.
- Output interface: ABI.
- Configuration programmable: Zero position, ABI line per revolution.
- ABI binary programmable decimal and binary pulse count: 1000, 500, 400, 300, 200, 100, 50, 25, 1024, 512, 256 ppr.

Output signal Connection

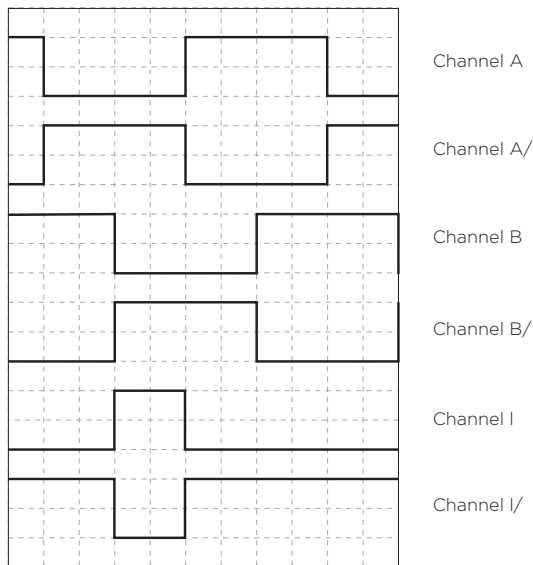

Direction of rotation: CCW viewed from front shaft end

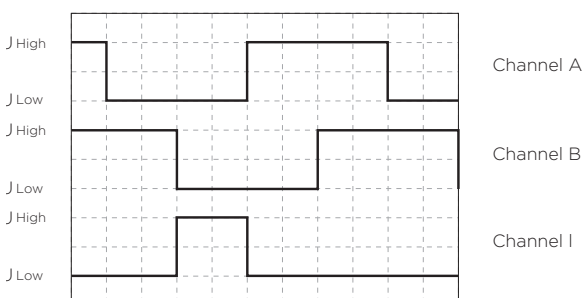

Connection	EN16; EN22A; EN22B; EN24	EN16L; EN22AL; EN22BL; EN24L	PVC
Pin 1	GND	GND	AWG28
Pin 2	Vcc	Vcc	AWG28
Pin 3	NC	I-	AWG28
Pin 4	I+	I+	AWG28
Pin 5	NC	B-	AWG28
Pin 6	B+	B+	AWG28
Pin 7	NC	A-	AWG28
Pin 8	A+	A+	AWG28

Connector: Standard DIN 41651 IDC, 8 pins, dual row 2.54x2.54mm.
Mating connector: Molex 7024-60801 or compatible

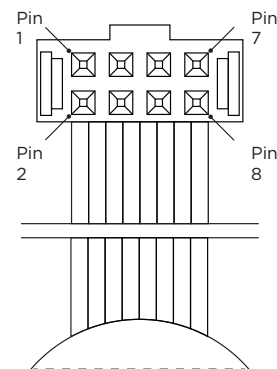

Servo Drives

DC and BLDC Motors

CANopen EtherCAT  

 Position Velocity Torque control

 PLC

 Extended temperature



In the industrial environment, high-performance drives must be used to ensure the electric motors' high performance and energy efficiency. Each drive controls motor operation according to specific control algorithms. Servotecnica offers servo drives with EtherCAT, Profinet, and CANopen protocols, supply voltages up to 60VDC.

Benefits

Programmable

Compact

Cost-effective

Features

Control mode	Position, velocity, torque
Fieldbus	CANopen, EtherCAT, Profinet
Supply Voltage	9..60 VDC
I/O	Analog and digital
Operating temperature	-40° +70° C

SVTE-A-E40-CanOpen Servo Drives

60VDC | 10A
DC motors, BLDC motors

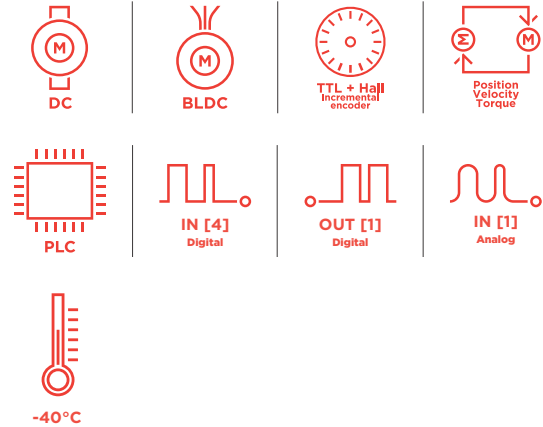
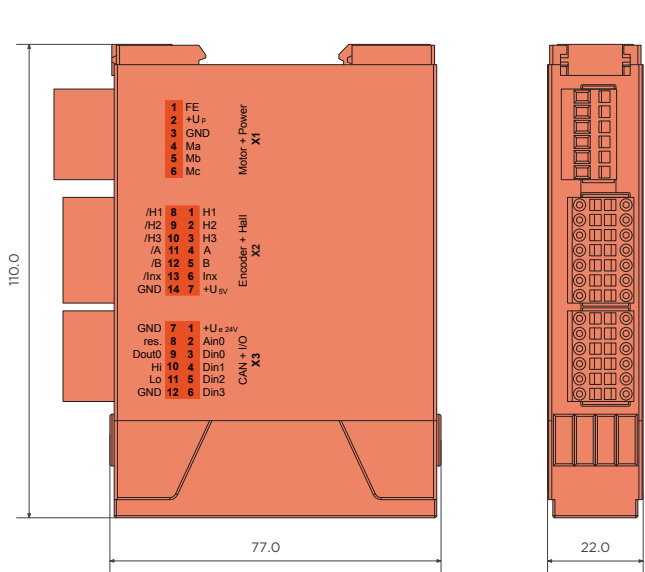

CANopen

Values	Unit
Power	
1 Electronic supply voltage U _e	VDC 9..30
2 Power supply voltage U _p	VDC 9..60
3 Max. output current	A 30
4 Continuous output current @ U _p =24VDC	A 10
5 Continuous output current @ U _p =48VDC	A 8.5
6 Output voltage	Up to 90%
Motor types	
7 DC motors	yes
8 BLDC motors	yes
9 Stepper motors	no
Mechanical	
10 Size LxWxH	mm 110 x 22.5 x 77
CAN bus	
11 Protocol	DS301
12 Device profile	DS402
13 Galvanically isolated	yes
Incremental encoder	
14 Input voltage (24VDC tolerant)	VDC 0..5
15 Signal type	differential, open collector, single ended
Hall sensors	
16 Input voltage (24VDC tolerant)	VDC 0..5
17 Signal type	differential, open collector, single ended
Digital input	
18 Number	4 (Din0..3)
Digital output	
19 Number	1 (Dout0..1)
20 Continuous output current	A 1.5 (Load: resistive, inductive)
Analog inputs	
21 Number	1 (Ain0..1)
22 Signal type	0..10 VDC, 12 Bit, single ended
Environment	
23 Operating temperature	°C -40...+70

Connection

X1 Motor		
1	FE	Functional earth
2	+Up	Power supply voltage
3	GND	Ground for power supply voltage
4	Ma	Motor phase A
5	Mb	Motor phase B
6	Mc	Motor phase C
X2 Hall and inc. encoder		
1	H1	Hall sensor 1
2	H2	Hall sensor 2
3	H3	Hall sensor 3
4	A	Inc. encoder, A channel
5	B	Inc. encoder, B channel
6	Inx	Inc. encoder, index channel
7	+U5V	5V output voltage for sensor supply Sensors: encoder, hall
8	/H1	Hall sensor 1 inverted
9	/H2	Hall sensor 2 inverted
10	/H3	Hall sensor 3 inverted
11	/A	Inc. encoder, A channel invert
12	/B	Inc. encoder, B channel inverted
13	/Inx	Inc. encoder, index channel inverted
14	GND	Ground for sensor supply (don't connect with system GND)
X3 I/O's and CAN		
1	+Ue24V	Electronic supply voltage
2	Ain0	Analog input 0
3	Din0	Digital input 0
4	Din1	Digital input 1
5	Din2	Digital input 2
6	Din3	Digital input 3
7	GND	Ground for electronic supply voltage
8	res.	Reserved
9	Dout0	Digital output 0
10	CAN Hi	CAN High
11	CAN Lo	CAN Low
12	CAN GND	CAN Ground

SVTE-A-E40-EtherCAT Servo Drives

60VDC | 10A
DC motors, BLDC motors

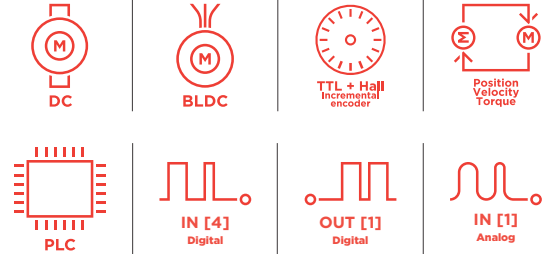
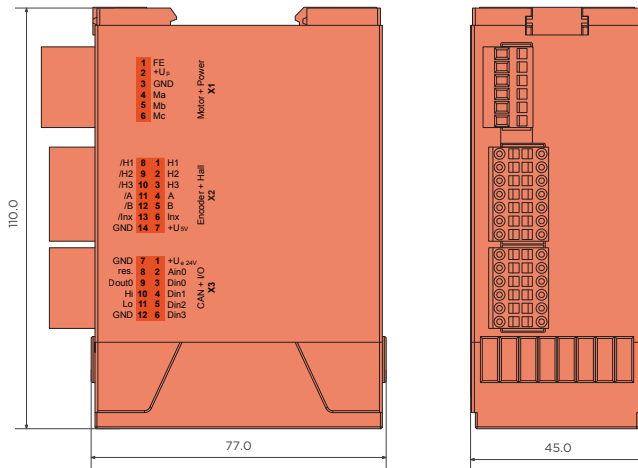

CANopen | EtherCAT

Values	Unit
Power	
1 Electronic supply voltage U _e	VDC 9..30
2 Power supply voltage U _p	VDC 9..60
3 Max. output current	A 30
4 Continuous output current @ U _p =24VDC	A 10
5 Continuous output current @ U _p =48VDC	A 8.5
6 Output voltage	Up to 90%
Motor types	
7 DC motors	yes
8 BLDC motors	yes
9 Stepper motors	no
Mechanical	
10 Size LxWxH	mm 110 x 45 x 77
CAN bus	
11 Protocol	DS301
12 Device profile	DS402
13 Galvanically isolated	no
EtherCAT	
14 Type	EtherCAT Slave
15 Physical layer	100 Base-Tx EtherCAT
16 Max. baudrate	100 Mbit/s
17 Number of ports	2xRJ45 (In,Out)
18 Protocol	CoE (CANopen over EtherCAT)
Incremental encoder	
19 Input voltage (24VDC tolerant)	VDC 0..5
20 Signal type	differential, open collector, single ended
Hall sensors	
21 Input voltage (24VDC tolerant)	VDC 0..5
22 Signal type	differential, open collector, single ended
Digital input	
23 Number	4 (Din0..3)
Digital output	
24 Number	1 (Dout0..1)
25 Continuous output current	A 1.5 (Load: resistive, inductive)
Analog inputs	
26 Number	1 (Ain0..1)
27 Signal type - Ain0	0..10 VDC, 12 Bit, single ended
Environment	
28 Operating temperature	°C -25...+70

Connection

X1 Motor		
1	FE	Functional earth
2	+Up	Power supply voltage
3	GND	Ground for power supply voltage
4	Ma	Motor phase A
5	Mb	Motor phase B
6	Mc	Motor phase C
X2 Hall and inc. encoder		
1	H1	Hall sensor 1
2	H2	Hall sensor 2
3	H3	Hall sensor 3
4	A	Inc. encoder, A channel
5	B	Inc. encoder, B channel
6	Inx	Inc. encoder, index channel
7	+U5V	5V output voltage for sensor supply Sensors: encoder, hall
8	/H1	Hall sensor 1 inverted
9	/H2	Hall sensor 2 inverted
10	/H3	Hall sensor 3 inverted
11	/A	Inc. encoder, A channel invert
12	/B	Inc. encoder, B channel inverted
13	/Inx	Inc. encoder, index channel inverted
14	GND	Ground for sensor supply (don't connect with system GND)
X3 I/O's and CAN		
1	+Ue24V	Electronic supply voltage
2	Ain0	Analog input 0
3	Din0	Digital input 0
4	Din1	Digital input 1
5	Din2	Digital input 2
6	Din3	Digital input 3
7	GND	Ground for electronic supply voltage
8	res.	Reserved
9	Dout0	Digital output 0
10	CAN Hi	CAN High
11	CAN Lo	CAN Low
12	CAN GND	CAN Ground
X5 EtherCAT - In port		
X6 EtherCAT - Out port		

SVTE-A-E45-CanOpen Servo Drives

60VDC | 10A
DC motors, BLDC motors

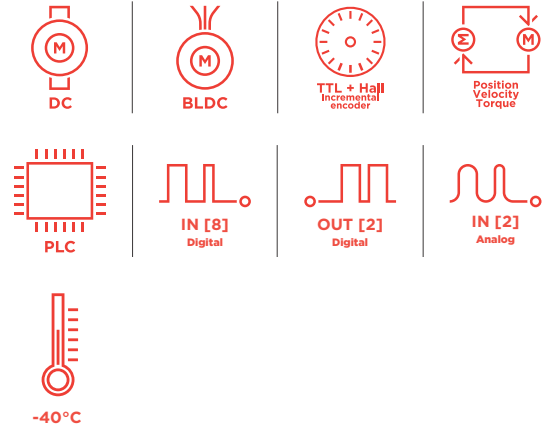
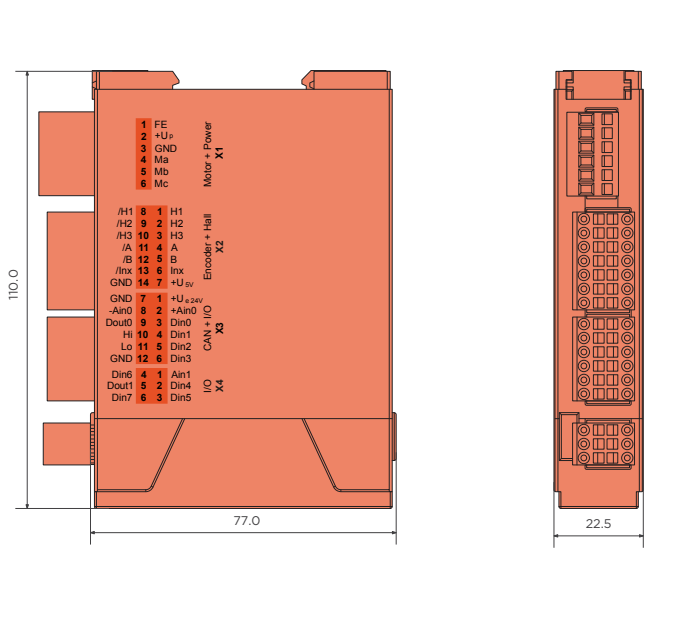

CANopen

Values	Unit
Power	
1 Electronic supply voltage U _e	VDC 9..30
2 Power supply voltage U _p	VDC 9..60
3 Max. output current	A 50
4 Continuous output current @ U _p =24VDC	A 10
5 Continuous output current @ U _p =48VDC	A 8.5
6 Output voltage	Up to 100%
Motor types	
7 DC motors	yes
8 BLDC motors	yes
9 Stepper motors	no
Mechanical	
10 Size LxWxH	mm 110 x 22.5 x 77
CAN bus	
11 Protocol	DS301
12 Device profile	DS402
13 Galvanically isolated	no
Incremental encoder	
14 Input voltage (24VDC tolerant)	V 0..5
15 Signal type	differential, open collector, single ended
Hall sensors	
16 Input voltage (24VDC tolerant)	V 0..5
17 Signal type	differential, open collector, single ended
Digital input	
18 Number	8 (Din0..7)
Digital output	
19 Number	2 (Dout0..1)
20 Continuous output current	A 1.5 (Load: resistive, inductive)
Analog inputs	
21 Number	2 (Ain0..1)
22 Signal type - Ain0	+/- 10 VDC, 12 Bit, differential
23 Signal type - Ain1	+/- 10 VDC, 12 Bit, single ended
Environment	
24 Operating temperature	°C -40...+70

Connection

X1 Motor		
1	FE	Functional earth
2	+Up	Power supply voltage
3	GND	Ground for power supply voltage
4	Ma	Motor phase A
5	Mb	Motor phase B
6	Mc	Motor phase C
X2 Hall and inc. encoder		
1	H1	Hall sensor 1
2	H2	Hall sensor 2
3	H3	Hall sensor 3
4	A	Inc. encoder, A channel
5	B	Inc. encoder, B channel
6	Inx	Inc. encoder, index channel
7	+U5V	5V output voltage for sensor supply Sensors: encoder, hall
8	/H1	Hall sensor 1 inverted
9	/H2	Hall sensor 2 inverted
10	/H3	Hall sensor 3 inverted
11	/A	Inc. encoder, A channel invert
12	/B	Inc. encoder, B channel inverted
13	/Inx	Inc. encoder, index channel inverted
14	GND	Ground for sensor supply (don't connect with system GND)
X3 I/O's and CAN		
1	+Ue24V	Electronic supply voltage
2	+Ain0	Analog input 0, positive
3	Din0	Digital input 0
4	Din1	Digital input 1
5	Din2	Digital input 2
6	Din3	Digital input 3
7	GND	Ground for electronic supply voltage
8	-Ain0	Analog input 0, negative
9	Dout0	Digital output 0
10	CAN Hi	CAN High
11	CAN Lo	CAN Low
12	CAN GND	CAN Ground
X4 I/O's		
1	Ain1	Analog input 1
2	Din4	Digital input 4
3	Din5	Digital input 5
4	Din6	Digital input 6
5	Dout1	Digital output 1
6	Din7	Digital input 7

SVTE-A-E45-EtherCAT Servo Drives

60VDC | 10A
DC motors, BLDC motors

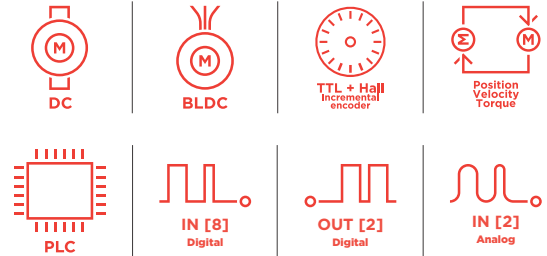
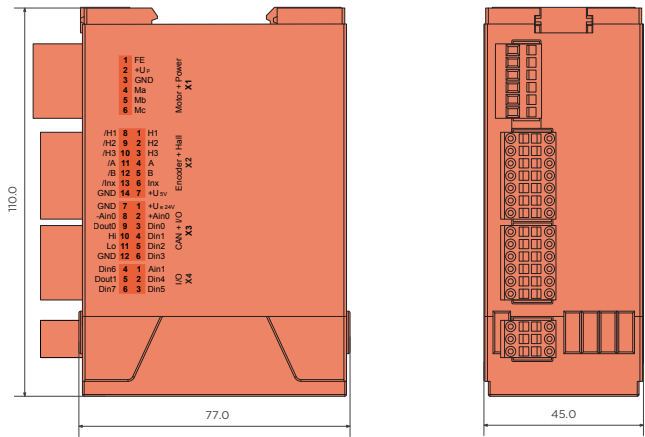

CANopen | EtherCAT

Values	Unit
Power	
1 Electronic supply voltage U _e	VDC 9..30
2 Power supply voltage U _p	VDC 9..60
3 Max. output current	A 50
4 Continuous output current @ U _p =24VDC	A 10
5 Continuous output current @ U _p =48VDC	A 8.5
6 Output voltage	Up to 100%
Motor types	
7 DC motors	yes
8 BLDC motors	yes
9 Stepper motors	no
Mechanical	
10 Size LxWxH	mm 110 x 45 x 77
CAN bus	
11 Protocol	DS301
12 Device profile	DS402
13 Galvanically isolated	no
EtherCAT	
14 Type	EtherCAT Slave
15 Physical layer	100 Base-Tx EtherCAT
16 Max. baudrate	100 Mbit/s
17 Number of ports	2xRJ45 (In,Out)
18 Protocol	CoE (CANopen over EtherCAT)
Incremental encoder	
19 Input voltage (24VDC tolerant)	VDC 0..5
20 Signal type	differential, open collector, single ended
Hall sensors	
21 Input voltage (24VDC tolerant)	VDC 0..5
22 Signal type	differential, open collector, single ended
Digital input	
23 Number	8 (Din0..7)
Digital output	
24 Number	2 (Dout0..1)
25 Continuous output current	A 1.5 (Load: resistive, inductive)
Analog inputs	
26 Number	2 (Ain0..1)
27 Signal type - Ain0	+/- 10 VDC, 12 Bit, differential
28 Signal type - Ain1	+/- 10 VDC, 12 Bit, single ended
Environment	
29 Operating temperature	°C -25...+70

Connection

X1 Motor		
1	FE	Functional earth
2	+Up	Power supply voltage
3	GND	Ground for power supply voltage
4	Ma	Motor phase A
5	Mb	Motor phase B
6	Mc	Motor phase C
X2 Hall and inc. encoder		
1	H1	Hall sensor 1
2	H2	Hall sensor 2
3	H3	Hall sensor 3
4	A	Inc. encoder, A channel
5	B	Inc. encoder, B channel
6	Inx	Inc. encoder, index channel
7	+U5V	5V output voltage for sensor supply Sensors: encoder, hall
8	/H1	Hall sensor 1 inverted
9	/H2	Hall sensor 2 inverted
10	/H3	Hall sensor 3 inverted
11	/A	Inc. encoder, A channel invert
12	/B	Inc. encoder, B channel inverted
13	/Inx	Inc. encoder, index channel inverted
14	GND	Ground for sensor supply (don't connect with system GND)
X3 I/O's and CAN		
1	+Ue24V	Electronic supply voltage
2	+Ain0	Analog input 0, positive
3	Din0	Digital input 0
4	Din1	Digital input 1
5	Din2	Digital input 2
6	Din3	Digital input 3
7	GND	Ground for electronic supply voltage
8	-Ain0	Analog input 0, negative
9	Dout0	Digital output 0
10	CAN Hi	CAN High
11	CAN Lo	CAN Low
12	CAN GND	CAN Ground
X4 I/O's		
1	Ain1	Analog input 1
2	Din4	Digital input 4
3	Din5	Digital input 5
4	Din6	Digital input 6
5	Dout1	Digital output 1
6	Din7	Digital input 7
X5 EtherCAT - In port		
X6 EtherCAT - Out port		

SVTE-A-E45-Profinet Servo Drives

60VDC | 10A
DC motors, BLDC motors

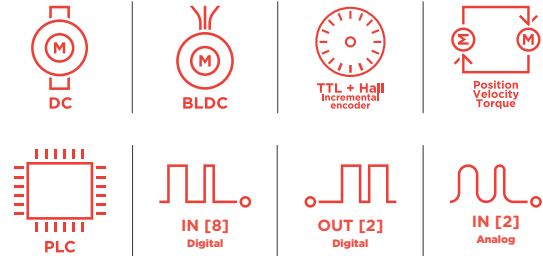
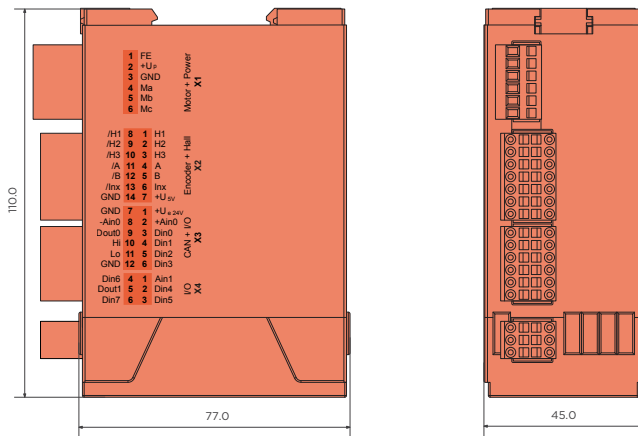

CANopen | PROFIBUS NET

Values	Unit
Power	
1 Electronic supply voltage Ue	VDC 9..30
2 Power supply voltage Up	VDC 9..60
3 Max. output current	A 50
4 Continuous output current @ Up=24VDC	A 10
5 Continuous output current @ Up=48VDC	A 8.5
6 Output voltage	Up to 100%
Motor types	
7 DC motors	yes
8 BLDC motors	yes
9 Stepper motors	no
Mechanical	
10 Size LxWxH	mm 110 x 45 x 77
CAN bus	
11 Protocol	DS301
12 Device profile	DS402
13 Galvanically isolated	no
Profinet	
14 Type	Slave
15 Physical layer	100 Base-Tx
16 Max. baudrate	100 Mbit/s
17 Number of ports	2xRJ45 (PORT1,PORT2)
Incremental encoder	
18 Input voltage (24VDC tolerant)	VDC 0..5
19 Signal type	differential, open collector, single ended
Hall sensors	
20 Input voltage (24VDC tolerant)	VDC 0..5
21 Signal type	differential, open collector, single ended
Digital input	
22 Number	8 (Din0..7)
Digital output	
23 Number	2 (Dout0..1)
24 Continuous output current	A 1.5 (Load: resistive, inductive)
Analog inputs	
25 Number	2 (Ain0..1)
26 Signal type - Ain0	+/- 10 VDC, 12 Bit, differential
27 Signal type - Ain1	+/- 10 VDC, 12 Bit, single ended
Environment	
28 Operating temperature	°C -25...+40

Connection

X1 Motor		
1	FE	Functional earth
2	+Up	Power supply voltage
3	GND	Ground for power supply voltage
4	Ma	Motor phase A
5	Mb	Motor phase B
6	Mc	Motor phase C
X2 Hall and inc. encoder		
1	H1	Hall sensor 1
2	H2	Hall sensor 2
3	H3	Hall sensor 3
4	A	Inc. encoder, A channel
5	B	Inc. encoder, B channel
6	Inx	Inc. encoder, index channel
7	+U5V	5V output voltage for sensor supply Sensors: encoder, hall
8	/H1	Hall sensor 1 inverted
9	/H2	Hall sensor 2 inverted
10	/H3	Hall sensor 3 inverted
11	/A	Inc. encoder, A channel invert
12	/B	Inc. encoder, B channel inverted
13	/Inx	Inc. encoder, index channel inverted
14	GND	Ground for sensor supply (don't connect with system GND)
X3 I/O's and CAN		
1	+Ue24V	Electronic supply voltage
2	+Ain0	Analog input 0, positive
3	Din0	Digital input 0
4	Din1	Digital input 1
5	Din2	Digital input 2
6	Din3	Digital input 3
7	GND	Ground for electronic supply voltage
8	-Ain0	Analog input 0, negative
9	Dout0	Digital output 0
10	CAN Hi	CAN High
11	CAN Lo	CAN Low
12	CAN GND	CAN Ground
X4 I/O's		
1	Ain1	Analog input 1
2	Din4	Digital input 4
3	Din5	Digital input 5
4	Din6	Digital input 6
5	Dout1	Digital output 1
6	Din7	Digital input 7
X5 Profinet - PORT1		
X6 Profinet - PORT2		

SVTE-A-E50-CanOpen Servo Drives

60VDC | 7.5A
DC motors, BLDC motors

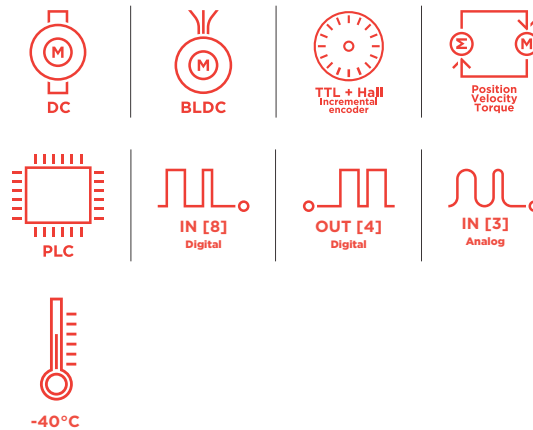
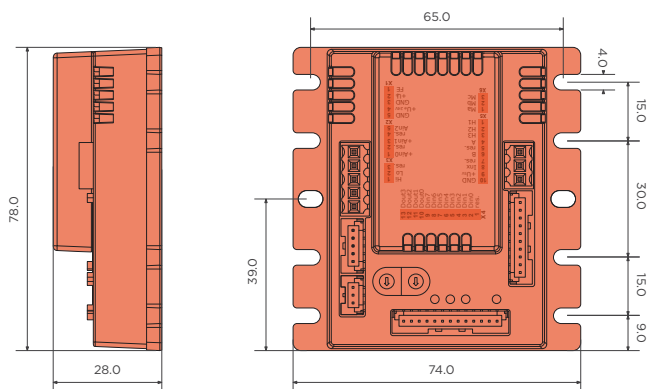

CANopen

Values	Unit
Power	
1 Electronic supply voltage U_e	VDC 9..30
2 Power supply voltage U_p	VDC 9..60
3 Max. output current	A 25
4 Continuous output current @ $U_p=24VDC$ (certified UL)	A 7.5
5 Continuous output current @ $U_p=60VDC$ (certified UL)	A 7
6 Output voltage	Up to 90%
Motor types	
7 DC motors	Yes
8 BLDC motors	Yes
9 Stepper motors	No
Mechanical	
10 Size LxWxH	mm 78 x 74 x 28
CAN bus	
11 Protocol	DS301
12 Device profile	DS402
13 Galvanically isolated	no
Incremental encoder	
14 Input voltage	VDC 0..5
15 Signal type	open collector, single ended
Hall sensors	
16 Input voltage	VDC 0..5
17 Signal type	open collector, single ended
Digital input	
18 Number	8 (Din0..7)
Digital output	
19 Number	4 (Dout0..3)
20 Continuous output current	A 0.3 (Load: resistive, inductive)
Analog inputs	
21 Number	3 (Ain0..2)
22 Signal type - Ain0..1	0..10V, 12 Bit, Single Ended
23 Signal type - Ain2	0..5V, 12 Bit, Single Ended
Environment	
24 Operating temperature	°C -40..+70°C

Connection

X1 Supply		
1	FE	Functional earth
2	+Up	Power supply voltage
3	GND	Ground for power supply voltage
4	+Ue24V	Electronic supply voltage
5	GND	Ground for electronic supply voltage
X2 Analog Inputs		
1	Ain0	Analog input 0
2	res.	Reserved
3	Ain1	Analog input 1
4	res.	Reserved
5	Ain2	Analog Input 2 (5V)
X3 CAN bus		
1	CAN Hi	CAN High
2	CAN Lo	CAN Low
3	res.	Reserved
X4 Digital inputs/outputs		
1	res.	Reserved
2	Din0	Digital input 0
3	Din1	Digital input 1
4	Din2	Digital input 2
5	Din3	Digital input 3
6	Din4	Digital input 4
7	Din5	Digital input 5
8	Din6	Digital input 6
9	Din7	Digital input 7
10	Dout0	Digital output 0
11	Dout1	Digital output 1
12	Dout2	Digital output 2
13	Dout3	Digital output 3
X5 Hall and inc. encoder		
1	H1	Hall sensor 1
2	H2	Hall sensor 2
3	H3	Hall sensor 3
4	A	Inc. encoder, A channel
5	res.	Reserved
6	B	Inc. encoder, B channel
7	res.	Reserved
8	Inx	Inc. encoder, index channel
9	+U5V	5V output voltage for sensor supply
10	GND	Ground for sensor supply (don't connect with system GND)
X6 Motor		
1	Ma	Motor phase A
2	Mb	Motor phase B
3	Mc	Motor phase C

SVTE-A-E55-CanOpen Servo Drives

60VDC | 10A
DC motors, BLDC motors

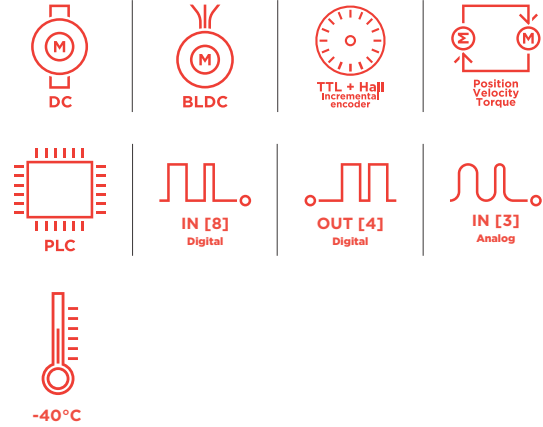
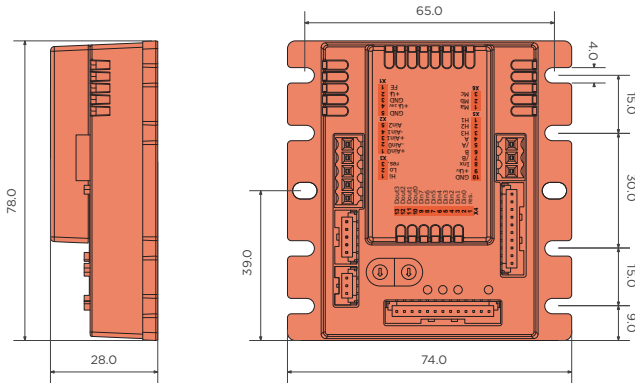

CANopen

Values	Unit
Power	
1 Electronic supply voltage Ue	VDC 9..30
2 Power supply voltage Up	VDC 9..60
3 Max. output current	A 50
4 Continuous output current @ Up=24VDC	A 10
5 Continuous output current @ Up=48VDC	A 8.5
6 Output voltage	Up to 100%
Motor types	
7 DC motors	yes
8 BLDC motors	yes
9 Stepper motors	no
Mechanical	
10 Size LxWxH	mm 78 x 74 x 28
CAN bus	
11 Protocol	DS301
12 Device profile	DS402
13 Galvanically isolated	no
Incremental encoder	
14 Input voltage (24VDC tolerant)	VDC 0..5
15 Signal type	differential, open collector, single ended, 2,5 kOhm input impedance
Hall sensor	
16 Input voltage	VDC 0..5
17 Signal type	open collector, single ended, 5Vdc pull up intern 920 Ohm
Digital input	
18 Number	8 (Din0..7)
Digital output	
19 Number	4 (Dout0..3)
20 Continuous output current	A 0.3 (Load: resistive, inductive)
Analog inputs	
21 Number	3 (Ain0..2)
22 Signal type - Ain0.1	+/- 10VDC, 12 Bit, differential, 200 kOhm input impedance
23 Signal type - Ain2	0..5 VDC, 12 Bit, single ended, 5VDC pull up intern 1,5 kOhm
Environment	
24 Operating temperature	°C -40...+70

Connection

X1 Supply		
1	FE	Functional earth
2	+Up	Power supply voltage
3	GND	Ground for power supply voltage
4	+Ue24V	Electronic supply voltage
5	GND	Ground for electronic supply voltage
X2 Analog Inputs		
1	+Ain0	Analog input 0, positive
2	-Ain0	Analog input 0, negative
3	+Ain1	Analog input 1, positive
4	-Ain1	Analog input 1, negative
5	Ain2	Analog Input 2 (5V)
X3 CAN bus		
1	CAN Hi	CAN High
2	CAN Lo	CAN Low
3	res.	Reserved
X4 Digital inputs/outputs		
1	res.	Reserved
2	Din0	Digital input 0
3	Din1	Digital input 1
4	Din2	Digital input 2
5	Din3	Digital input 3
6	Din4	Digital input 4
7	Din5	Digital input 5
8	Din6	Digital input 6
9	Din7	Digital input 7
10	Dout0	Digital output 0
11	Dout1	Digital output 1
12	Dout2	Digital output 2
13	Dout3	Digital output 3
X5 Hall and inc. encoder		
1	H1	Hall sensor 1
2	H2	Hall sensor 2
3	H3	Hall sensor 3
4	A	Inc. encoder, A channel
5	/A	Inc. encoder, A channel invert
6	B	Inc. encoder, B channel
7	/B	Inc. encoder, B channel inverted
8	Inx	Inc. encoder, index channel
9	+U5V	5V output voltage for sensor supply
10	GND	Ground for sensor supply (don't connect with system GND)
X6 Motor		
1	Ma	Motor phase A
2	Mb	Motor phase B
3	Mc	Motor phase C

SVTE-A-E55-EtherCAT Servo Drives

60VDC | 8A
DC motors, BLDC motors

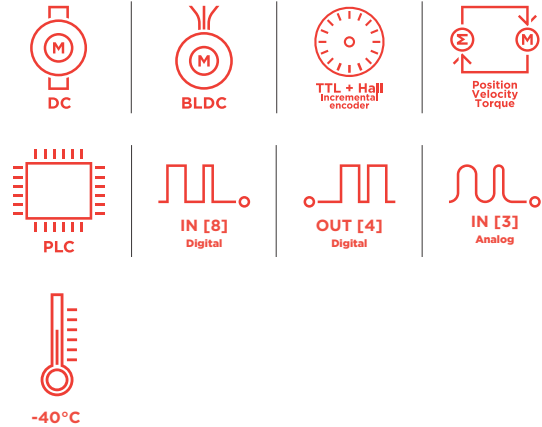
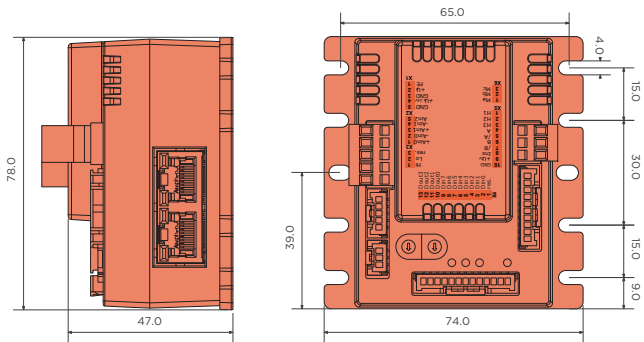

CANopen | EtherCAT

Values	Unit
Power	
1 Electronic supply voltage U _e	VDC 9..30
2 Power supply voltage U _p	VDC 9..60
3 Max. output current	A 50
4 Continuous output current	A 8
5 Output voltage	Up to 100%
Motor types	
6 DC motors	yes
7 BLDC motors	yes
8 Stepper motors	no
Mechanical	
9 Size LxWxH	mm 78x74x47
CAN bus	
10 Protocol	DS301
11 Device profile	DS402
12 Galvanically isolated	no
EtherCAT	
13 Type	EtherCAT Slave
14 Physical layer	100 Base-Tx EtherCAT
15 Max. baudrate	100 Mbit/s
16 Number of ports	2xRJ45 (In,Out)
17 Protocol	CoE (CANopen over EtherCAT)
Incremental encoder	
18 Input voltage (24VDC tolerant)	0..5
19 Signal type	differential, open collector, single ended
Hall sensors	
20 Input voltage	0..5
21 Signal type	open collector, single ended
Digital input	
22 Number	8 (Din0..7)
Digital output	
23 Number	4 (Dout0..3)
24 Continuous output current	A 0.3 (Load: resistive, inductive)
Analog inputs	
25 Number	3 (Ain0..2)
26 Signal type - Ain0..1	+/- 10 VDC, 12 Bit, differential
27 Signal type - Ain2	0..5VDC, 12 Bit, single ended
Environment	
28 Operating temperature	°C -40...+70

Connection

X1 Supply		
1	FE	Functional earth
2	+Up	Power supply voltage
3	GND	Ground for power supply voltage
4	+Ue24V	Electronic supply voltage
5	GND	Ground for electronic supply voltage
X2 Analog Inputs		
1	+Ain0	Analog input 0, positive
2	-Ain0	Analog input 0, negative
3	+Ain1	Analog input 1, positive
4	-Ain1	Analog input 1, negative
5	Ain2	Analog Input 2 (5V)
X3 CAN bus		
1	CAN Hi	CAN High
2	CAN Lo	CAN Low
3	res.	Reserved
X4 Digital inputs/outputs		
1	res.	Reserved
2	Din0	Digital input 0
3	Din1	Digital input 1
4	Din2	Digital input 2
5	Din3	Digital input 3
6	Din4	Digital input 4
7	Din5	Digital input 5
8	Din6	Digital input 6
9	Din7	Digital input 7
10	Dout0	Digital output 0
11	Dout1	Digital output 1
12	Dout2	Digital output 2
13	Dout3	Digital output 3
X5 Hall and inc. encoder		
1	H1	Hall sensor 1
2	H2	Hall sensor 2
3	H3	Hall sensor 3
4	A	Inc. encoder, A channel
5	/A	Inc. encoder, A channel invert
6	B	Inc. encoder, B channel
7	/B	Inc. encoder, B channel inverted
8	Inx	Inc. encoder, index channel
9	+U5V	5V output voltage for sensor supply
10	GND	Ground for sensor supply (don't connect with system GND)
X6 Motor		
1	Ma	Motor phase A
2	Mb	Motor phase B
3	Mc	Motor phase C
X7 EtherCAT - In port		
X8 EtherCAT - Out port		

SVTE-A-E55-Profinet Servo Drives

60VDC | 9A
DC motors, BLDC motors

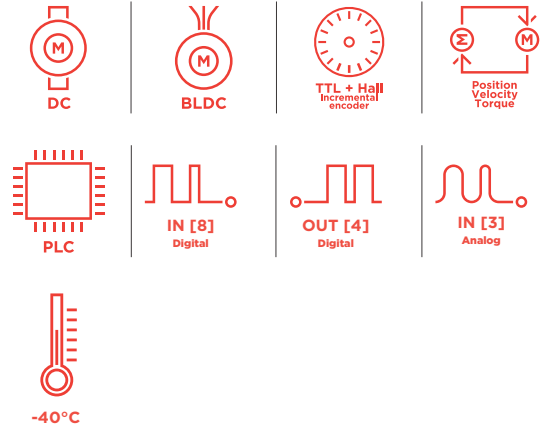
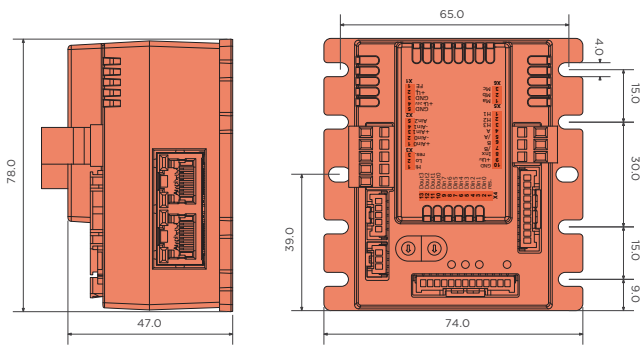

Values	Unit
Power	
1 Electronic supply voltage Ue	VDC 9..30
2 Power supply voltage Up	VDC 9..60
3 Max. output current	A 50
4 Continuous output current @ Up=24VDC	A 9
5 Continuous output current @ Up=48VDC	A 8
6 Output voltage	Up to 100%
Motor types	
7 DC motors	yes
8 BLDC motors	yes
9 Stepper motors	no
Mechanical	
10 Size LxWxH	mm 78 x 74 x 47
CAN bus	
11 Protocol	DS301
12 Device profile	DS402
13 Galvanically isolated	no
Profinet	
14 Type	Slave
15 Physical layer	100 Base-Tx
16 Max. baudrate	100 Mbit/s
17 Number of ports	2xRJ45 (PORT1, PORT2)
Incremental encoder	
18 Input voltage (24VDC tolerant)	VDC 0..5
19 Signal type	differential, open collector, single ended, 2.5 kOhm input impedance
Hall sensors	
20 Input voltage	VDC 0..5
21 Signal type	open collector, single ended, 5VDC pull up intern 920 Ohm
Digital input	
22 Number	8 (Din0..7)
Digital output	
23 Number	4 (Dout0..3)
24 Continuous output current	A 0.3 (Load: resistive, inductive)
Analog inputs	
25 Number	3 (Ain0..2)
26 Signal type - Ain0..1	+/- 10 VDC, 12 Bit, differential, 20 kOhm input impedance
27 Signal type - Ain2	0.5 VDC, 12 Bit, single ended, 5VDC pull up intern 1.5 kOhm
Environment	
28 Operating temperature	°C -40...+70

Connection

X1 Supply		
1	FE	Functional earth
2	+Up	Power supply voltage
3	GND	Ground for power supply voltage
4	+Ue24V	Electronic supply voltage
5	GND	Ground for electronic supply voltage
X2 Analog Inputs		
1	+Ain0	Analog input 0, positive
2	-Ain0	Analog input 0, negative
3	+Ain1	Analog input 1, positive
4	-Ain1	Analog input 1, negative
5	Ain2	Analog Input 2 (5V)
X3 CAN bus		
1	CAN Hi	CAN High
2	CAN Lo	CAN Low
3	res.	Reserved
X4 Digital inputs/outputs		
1	res.	Reserved
2	Din0	Digital input 0
3	Din1	Digital input 1
4	Din2	Digital input 2
5	Din3	Digital input 3
6	Din4	Digital input 4
7	Din5	Digital input 5
8	Din6	Digital input 6
9	Din7	Digital input 7
10	Dout0	Digital output 0
11	Dout1	Digital output 1
12	Dout2	Digital output 2
13	Dout3	Digital output 3
X5 Hall and inc. encoder		
1	H1	Hall sensor 1
2	H2	Hall sensor 2
3	H3	Hall sensor 3
4	A	Inc. encoder, A channel
5	/A	Inc. encoder, A channel invert
6	B	Inc. encoder, B channel
7	/B	Inc. encoder, B channel inverted
8	Inx	Inc. encoder, index channel
9	+U5V	5V output voltage for sensor supply
10	GND	Ground for sensor supply (don't connect with system GND)
X6 Motor		
1	Ma	Motor phase A
2	Mb	Motor phase B
3	Mc	Motor phase C
X7 Profinet - In port		
X8 Profinet - Out port		

PCB Board & Cables

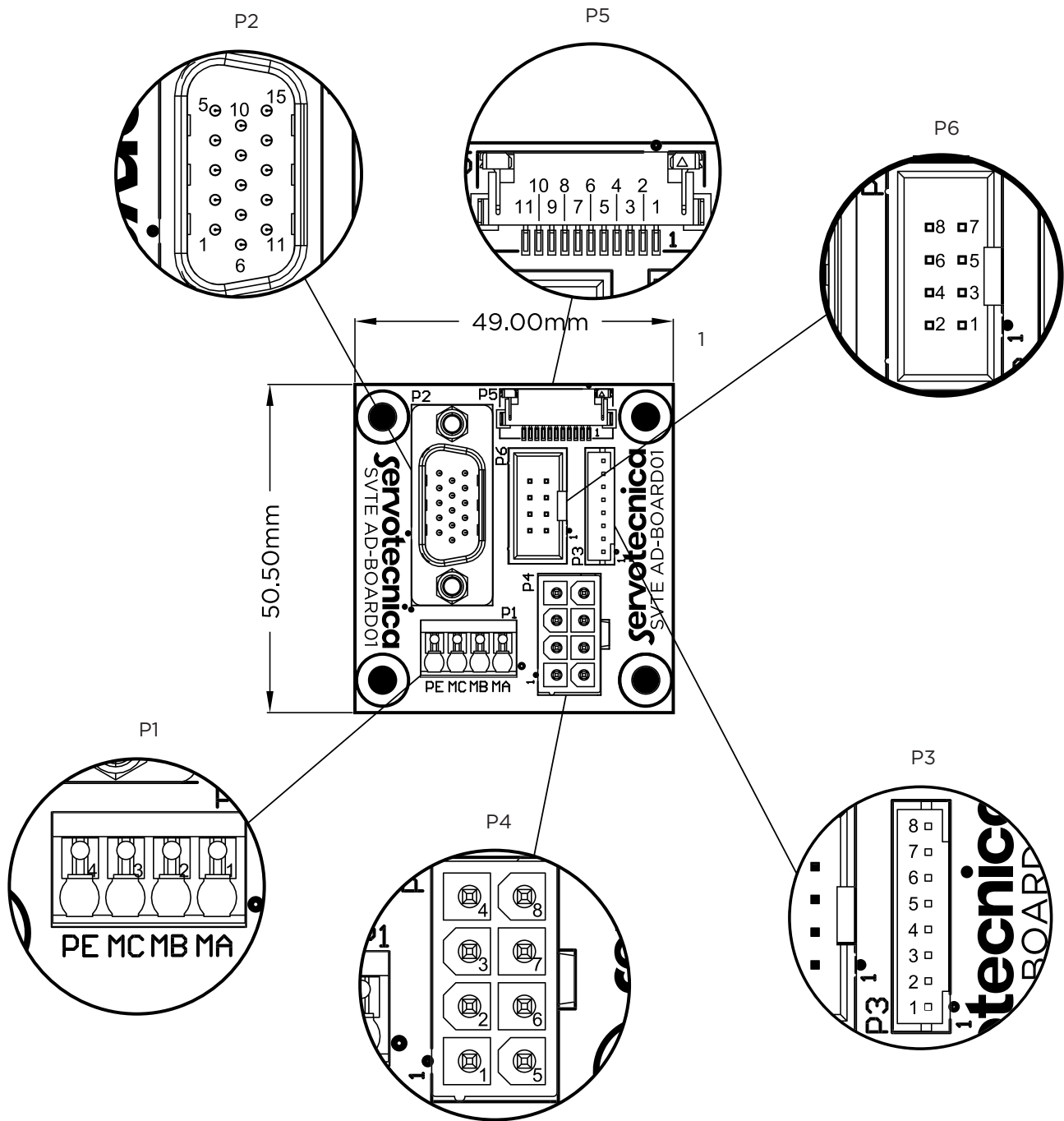

PCB Board - SVTE AD-BOARD01

PIN	Connection P2
1	+5VD
2	GND
3	N.C.
4	H1+
5	N.C.
6	I+
7	B+
8	A+
9	H3 +
10	H2 +
11	I /
12	B/
13	A/
14	N.C.
15	N.C.
16/17	SHIELD

PIN	Connection P5
1	+5VD
2	H3+
3	H1+
4	H2+
5	GND
6/7	Phase - C
8/9	Phase - B
10/11	Phase - A

PIN	Connection P6
1	GND
2	+5VD
3	I /
4	I+
5	B /
6	B+
7	A/
8	A+

PIN	Connection P3
1	+5VD
2	H1+
3	H2+
4	H3+
5	GND
6	Phase - A
7	Phase - B
8	Phase - C

PIN	Connection P4
1	Phase - B
2	+5VD
3	H1+
4	H3+
5	Phase - A
6	Phase - C
7	GND
8	H2+

PIN	Connection P1
1	Phase - A
2	Phase - B
3	Phase - C
4	PE

Cables

Model	Length [m]	Electronics
Encoder cable e4x for svtn/svtm low voltage 1mt	1	SVTE-A-E4x
Encoder cable e4x for svtn/svtm low voltage 3mt	3	SVTE-A-E4x
Encoder cable e5x for svtn/svtm low voltage 1mt	1	SVTE-A-E5x
Encoder cable e5x for svtn/svtm low voltage 3mt	3	SVTE-A-E5x

Contacts

HEADQUARTERS - ITALY



Servotecnica S.p.A.
Via E. Majorana, 4
20834 Nova Milanese (MB) - Italy
+39 0362 4921 | info@servotecnica.com

GERMANY



Servotecnica GmbH
Kelsterbacher Str. 20
65479 Raunheim - Deutschland
+49 6142-7936039 | info@servotecnica.de

UNITED STATES



Fair Oaks, California
+1 925-640-7042 | mimobersteg@servotecnica.com

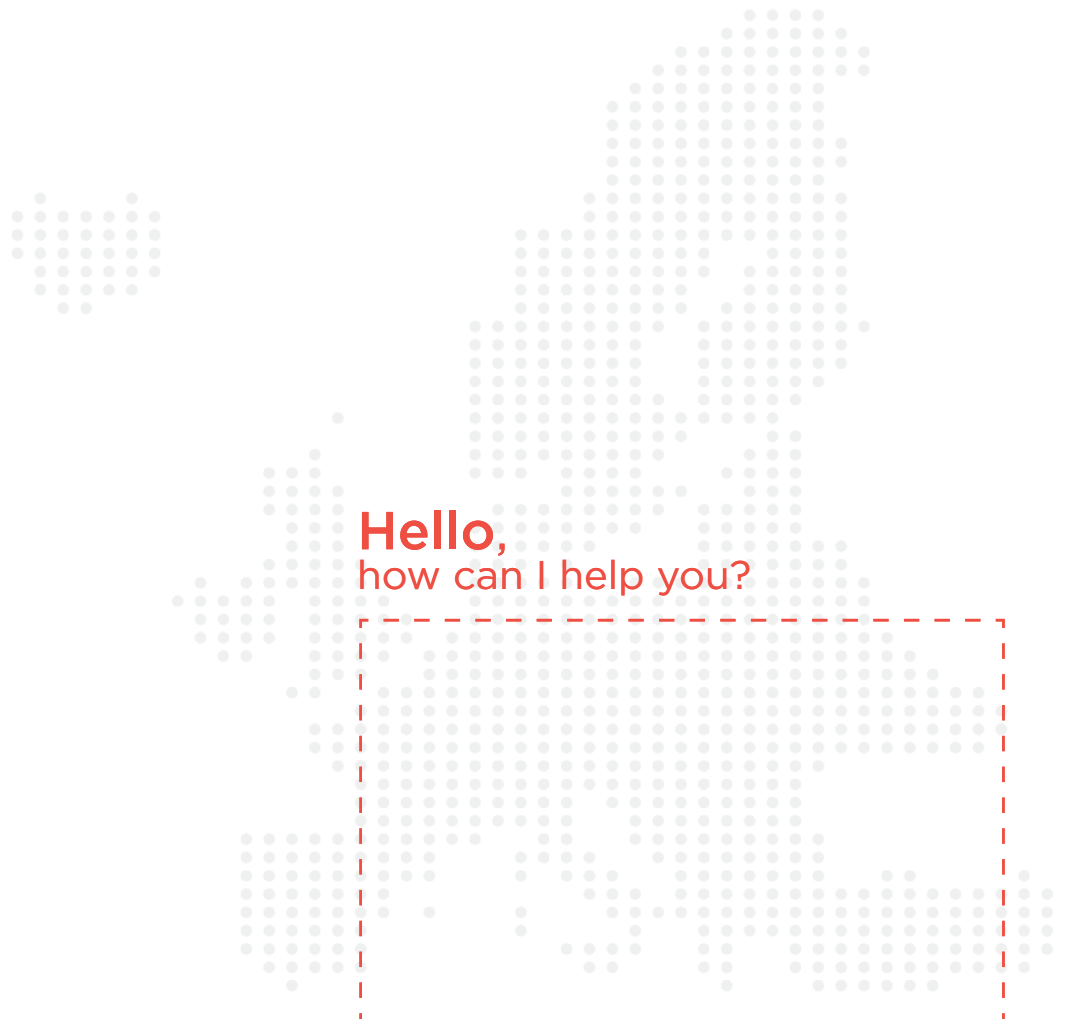

Hello,
how can I help you?

